

CATALOGO

CATALOG - CATALOGUE - KATALOG

2025



LA STORIA DI MAFFEI

IT Borgomanero, 1935. Maffei Stefano e Vittorio davanti al negozio di famiglia.

EN Borgomanero, 1935. Maffei Stefano and Vittorio in front of the family shop.

FR Borgomanero, 1935. Maffei Stefano et Vittorio devant la boutique familiale.

DE Borgomanero, 1935. Maffei Stefano und Vittorio vor dem Familienladen.



1935

IT Borgomanero, 1954. Stabilimento Maffei

EN Borgomanero, 1954. Maffei facility

FR Borgomanero, 1954. Usine Maffei

DE Borgomanero, 1954. Maffei Werk



1953

1954

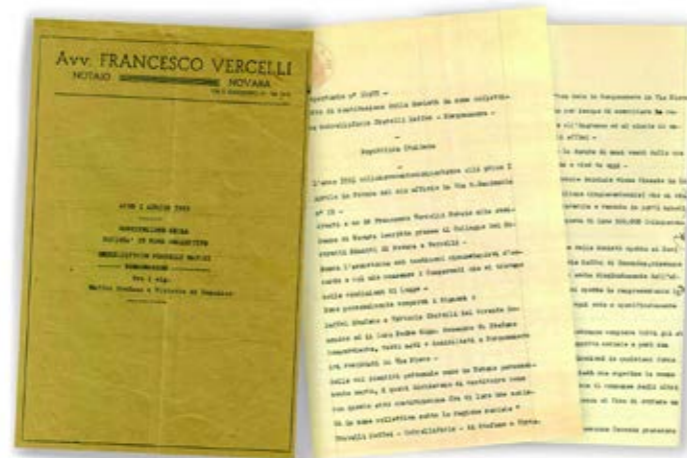

IT Borgomanero, 01/04/1953. Atto costitutivo Maffei
 EN Borgomanero, 01/04/1953. Act of association Maffei
 FR Borgomanero, 01/04/1953. Fondation Maffei
 DE Borgomanero, 01/04/1953. Satzung Maffei

IT Gattico-Veruno, 2024. Stabilimento Maffei

EN Gattico-Veruno, 2024. Maffei facility

FR Gattico-Veruno, 2024. Usine Maffei

DE Gattico-Veruno, 2024. Maffei Werk



1959

2024



IT I primi cataloghi
 FR Les premiers catalogues
 EN The first catalogues
 DE Die ersten Kataloge



IT Maffei Srl è un'azienda in grado di offrire una collezione di ombrelloni, basi, cuscini, fodere e vele Made in Italy. Il nostro obiettivo è proporre articoli di qualità, tecnicamente e stilisticamente all'avanguardia, realizzati con i migliori materiali per soddisfare le diverse esigenze della clientela: molti dei prodotti offerti sono brevettati ed esclusivi, composti da materiali ad alta tecnologia tessile, che li rende unici sul mercato dell'outdoor. Ogni anno ci impegniamo ad aggiungere novità e prodotti esclusivi frutto di un attento esame delle nuove esigenze del mercato.

EN Maffei srl is a company that can offer a collection of garden and sun umbrellas, bases, protection covers, shade sails, technically and stylistically avant-garde, with the selection of the best materials and the experience of our staff: some products of this catalogue are our exclusivity as design or technique which make them unique on the market. Our goal is to add new products every season to be really up to date.

FR Maffei srl est une entreprise qui offre une collection de parasols, pieds, coussins, housses et voiles made in Italy. Notre objectif est de proposer des produits de qualité, techniquement et stylistiquement à l'avant-garde, en sélectionnant les meilleurs matériaux avec l'expérience de notre équipe: des produits dans notre catalogue sont notre exclusivité comme design ou technique, qui les font uniques sur le marché. Chaque saison nous nous engageons à ajouter des nouveaux produits pour suivre les tendances.

DE Maffei ist eine Firma daß eine Kollektion von Sonnenschirme, Fußsen, Auflagen, Sonnensegeln technisch und stilistisch Avantgarde bietet, mit der Auswahl der besten Lieferanten und der Erfahrung unserer Mitarbeiter: einige Produkte sind unsere Exklusivität wie Design oder Technik, damit sind einzigartig auf dem Markt. Je Saison, versuchen wir Neuigkeiten hinzuzufügen, um immer aktualisiert werden.

IT Con orgoglio festeggiamo i 70 anni d'attività
 EN With pride we celebrate 70 years of business
 FR Nous célébrons fierement 70 ans d'affaire
 DE Mit Stolz feiern wir 70 Jahre unserer Tätigkeit



IT **INDICE** EN **INDEX** FR **SOMMAIRE** DE **INHALT**

IT Ombrelloni laterali EN <i>Side pole parasols</i> FR <i>Parasols déportés</i> DE <i>Ampelschirme</i>	Polo Prince Vik Urban Fibraplus	08-19 20-29 30-37 38-45 46-53
IT Ombrelloni centrali EN <i>Central pole parasols</i> FR <i>Parasols à mât central</i> DE <i>Sonnenschirme mit Mittelmast</i>	James T Fibramax Decò Permar Classico Permar Curvo Permar Pagoda Alfa Beta Zanzibar Superinox	54-61 60-69 70-77 78-85 86-93 94-101 102-109 110-119 120-125 126-133
IT Accessori basi e fodere EN <i>Accessories bases and covers</i> FR <i>Accessoires bases et housses</i> DE <i>Zubehör Sockel und Schutzhüllen</i>		134-143
IT Tessuti - Tipologia EN <i>Fabrics - Typology</i> FR <i>Tissus - Typologie</i> DE <i>Stoffe - Typologie</i>	Intro AcrilMa Pool Raytent Nautilus Special TexMa Dralon PolyMa Mytex	144-145 146-148 149 150-151 152 153 154-155 156 157 158-159
IT Spiegazione dati tecnici EN <i>Please read the following notes on the technical datas</i> FR <i>Explication des données techniques</i> DE <i>Erklärung der technischen Daten</i>		160

IT **MISURE** EN **SIZES**
FR **TAILLES** DE **GRÖßEN**

IT ROTONDI EN ROUND FR RONDS DE RUND	IT PAGINA EN PAGE FR PAGE DE SEITE	IT PESO MINIMO BASE* EN MINIMUM BASE WEIGHT* FR MINIMUM BASE POIDS* DE MINDESTGEWICHT DER BASIS*
Ø 180	SI180-8 SUPERINOX	126-133
Ø 200	AL200-8 ALFA	102-109
	PM200-10 PERMAR	78-85
	SI200-10 SUPERINOX	126-133
	ZA200-8 ZANZIBAR	120-125
Ø 220	PM220-10 PERMAR	78-85
	PM220-10CUR PERMAR	86-93
	PM220-10PAG PERMAR	94-101
Ø 250	AL250-10 ALFA	102-109
Ø 300	AL300-10 ALFA	102-109
Ø 300	DE300-8 DECO	70-77
Ø 400	DE400-8 DECO	70-77

IT QUADRATI EN SQUARE FR CARRES DE ECKIG	IT PAGINA EN PAGE FR PAGE DE SEITE	IT PESO MINIMO BASE* EN MINIMUM BASE WEIGHT* FR MINIMUM BASE POIDS* DE MINDESTGEWICHT DER BASIS*
210X210	BE2121 BETA	110-119
250X250	BE2525 BETA	110-119
300X300	DE3030 DECO	70-77
	FM3030 FIBRAMAX	60-69
400X400	DE4040 DECO	70-77
	JAT4040 JAMES	54-61

IT RETTANGOLARI EN RECTANGULAR FR RECTANGULAIRE DE RECHTECKIG	IT PAGINA EN PAGE FR PAGE DE SEITE	IT PESO MINIMO BASE* EN MINIMUM BASE WEIGHT* FR MINIMUM BASE POIDS* DE MINDESTGEWICHT DER BASIS*
300X400	DE3040 DECO	70-77
	JAT3040 JAMES	54-61
	FM3040 FIBRAMAX	60-69

IT SEMIQUADRI EN HALF SQUARE FR DEMI CARRES DE HALB QUADRATISCH	IT PAGINA EN PAGE FR PAGE DE SEITE	IT PESO MINIMO BASE* EN MINIMUM BASE WEIGHT* FR MINIMUM BASE POIDS* DE MINDESTGEWICHT DER BASIS*
Ø 200	AL200-8SQ ALFA	102-109

IT LATERALI QUADRATI EN SQUARE SIDE POLE FR DEPORTES CARRES DE ECKIGE AMPELSCHIRME	IT PAGINA EN PAGE FR PAGE DE SEITE	IT PESO MINIMO BASE* EN MINIMUM BASE WEIGHT* FR MINIMUM BASE POIDS* DE MINDESTGEWICHT DER BASIS*
250X250	P6-1 POLO	08-19
	P7 PRINCE	20-29
300X300	P6-1XL POLO	08-19
	P7XL PRINCE	20-29
	UR3030 URBAN	38-45
350X350	FM3535 FIBRAPLUS	46-53
400X400	VIK4040 VIK	30-37
515X515	P6-4 POLO	08-19
615X615	P6-4XL POLO	08-19
615X615	P6-3XL POLO	08-19

IT LATERALI RETTANGOLARI EN RECTANGULAR SIDE POLE FR DEPORTE RECTANGULAIRES DE RECHTECKIGE AMPELSCHIRME	IT PAGINA EN PAGE FR PAGE DE SEITE	IT PESO MINIMO BASE* EN MINIMUM BASE WEIGHT* FR MINIMUM BASE POIDS* DE MINDESTGEWICHT DER BASIS*
300X400	FM3040 FIBRAPLUS	46-53
	UR3040 URBAN	38-45
515X250	P6-2 POLO	08-19
615X300	P6-2XL POLO	08-19

IT LATERALI ROTONDI EN ROUND SIDE POLE FR DEPORTES RONDS DE RUNDE AMPELSCHIRME	IT PAGINA EN PAGE FR PAGE DE SEITE	IT PESO MINIMO BASE* EN MINIMUM BASE WEIGHT* FR MINIMUM BASE POIDS* DE MINDESTGEWICHT DER BASIS*
Ø 350	P6-1RND POLO	08-19
	P7RND PRINCE	20-29
Ø 350X710	P6-2RND POLO	08-19
Ø 420	P6-1RNDXL POLO	08-19
	P7RNDXL PRINCE	20-29
Ø 420X840	P6-2RNDXL POLO	08-19

IT LATERALI AD ANGOLO EN CORNER SIDE POLE FR DEPORTE A COIN DE ECKFORM AMPELSCHIRME	IT PAGINA EN PAGE FR PAGE DE SEITE	IT PESO MINIMO BASE* EN MINIMUM BASE WEIGHT* FR MINIMUM BASE POIDS* DE MINDESTGEWICHT DER BASIS*
515X515		08-19
615X615		20-29

IT *Il peso minimo della base viene calcolato in caso di condizioni atmosferiche e di terreno normali

EN * The minimum base weight is calculated under normal atmospheric and soil conditions.

FR *Le poids minimal de la base est calculé dans le cas de conditions meteo et de sol normales.

DE *Das mindestgewicht der basis wird unter normalen atmosphärischen und bodenverhältnissen berechnet.

POLO

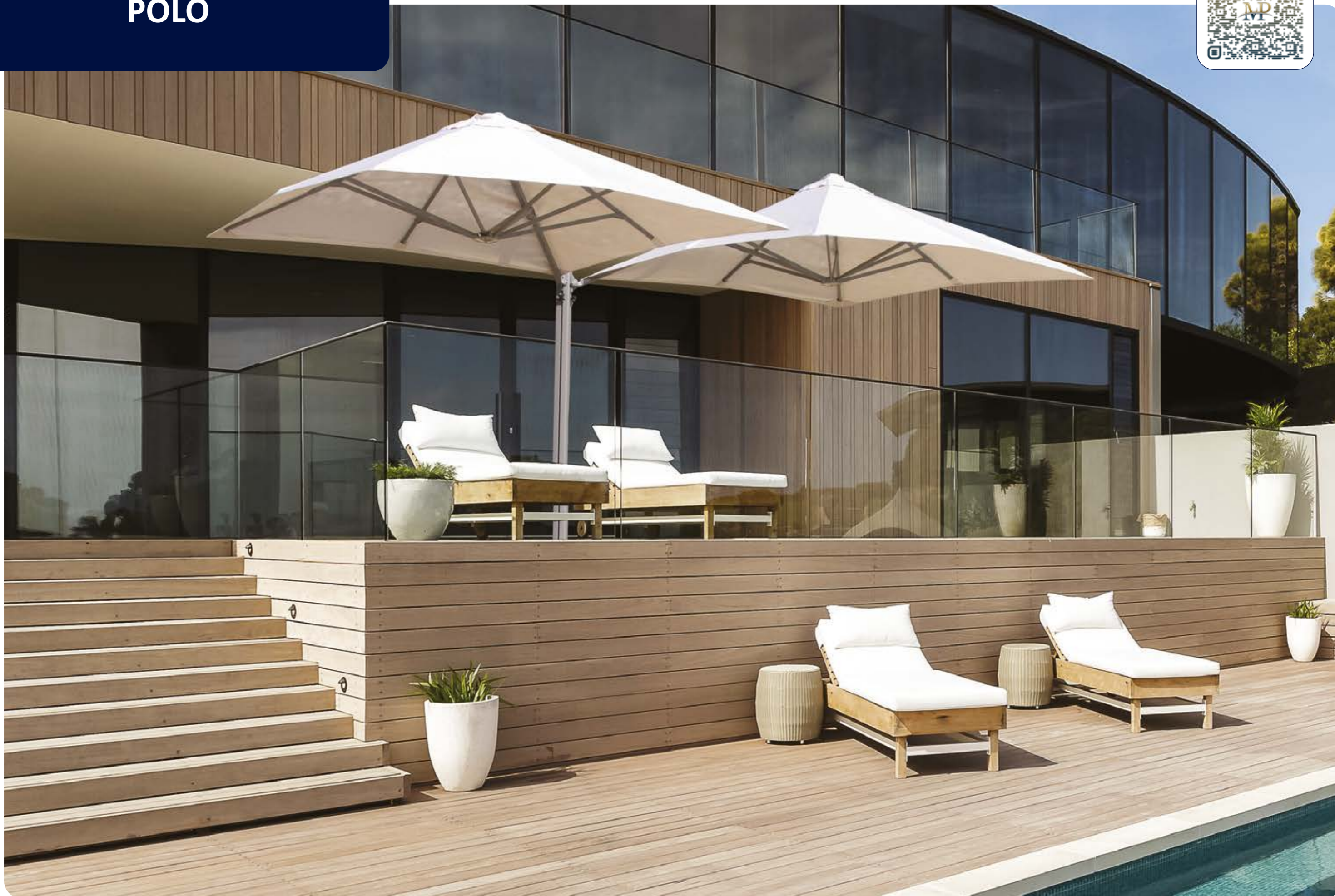

POLO

IT Il Polo è un ombrellone modulare, composto da 1 palo centrale, nel quale possono essere assemblati da 1 a 4 ombrelloni fino ad arrivare ad un'area coperta di 38m². Il singolo ombrellone è disponibile in forma quadrata nella misura cm 250x250 e 300x300(XL); in forma rotonda Ø 350 e Ø 420(XL).

EN The Polo is a modular umbrella, made up of 1 central pole, in which 1 to 4 umbrellas can be assembled up to a covered area of 38m². The single umbrella is available in square shape in the size cm 250x250 and 300x300(XL); in round shape Ø 350 and Ø 420(XL).

FR Le Polo est un parasol modulaire, composé par 1 mât central, dans lequel de 1 à 4 parasols peuvent être assemblés jusqu'à une surface couverte de 38m². Le parasol simple est disponible en forme carrée dans les tailles cm 250x250 et 300x300(XL) ; en forme ronde Ø 350 et Ø 420(XL).

DE Der Polo ist ein modulares Sonnenschirm-System, bestehend aus einem zentralen Mast, in den 1 bis 4 Sonnenschirme montiert werden können, um eine überdachte Fläche von 38 Quadratmetern zu erreichen. Der einzelne Sonnenschirm ist in quadratischer Form in den Größen 250x250 cm und 300x300 cm (XL) sowie in runder Form mit einem Durchmesser von 350 cm und 420 cm (XL) erhältlich.



IT Apertura manuale senza corde o manovelle.
EN Manual opening without ropes or cranks.
FR Ouverture manuelle sans cordes ni manivelles.
DE Manuelles Öffnen ohne Seile oder Kurbeln.



IT Molla a gas per facilitare l'apertura.
EN Gas spring to facilitate opening.
FR Ressort à gaz pour faciliter l'ouverture.
DE Gasfeder erleichtert das Öffnen.



IT Bacchette alluminio mm 20x25.
EN Aluminum ribs 20x25 mm.
FR Baleines aluminium 20x25 mm.
DE Aluminium Streben 20x25 mm.

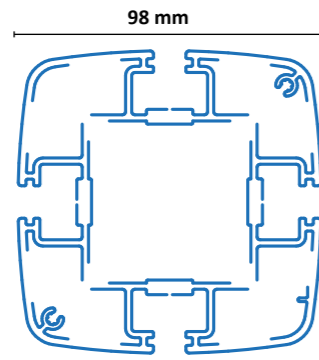

IT Palo mm 98x98 in alluminio modulare (da 1 a 4 ombrelloni).
EN Aluminium pole 98x98 mm modular (from 1 to 4 parasols).
FR Mât aluminium 98x98 mm modulaire (de 1 à 4 parasols).
DE Aluminiummast 98x98 mm modularem.



IT Colori Ral 9005 nero e Ral 9016 bianco.
EN Colors Ral 9005 black and Ral 9016 white.
FR Couleurs Ral 9005 noir et Ral 9016 blanc.
DE Farben RAL 9005 schwarz und RAL 9016 weiß.



IT Colori Ral 9007 Grigio e Anodizzato Bronzo.
EN Colors Ral 9007 Gray and Anodized Bronze.
FR Couleurs Gris Ral 9007 et Bronze Anodisé.
DE Farben RAL 9007 Grau und eloxierte Bronze.



POLO

IT **COMBINAZIONI CON BASE A TERRA**
FR **COMBINAISONS AVEC PIED AU SOL**

EN **GROUND BASE COMBINATIONS**
DE **SYSTEM MIT BODENFUSS**

IT L'ombrellone Polo può essere composto da 1,2,3 o 4 ombrelloni su un palo. Ogni ombrellone può essere montato ed usato separatamente. Quindi si potrà decidere con molta flessibilità se avere il sole o l'ombra. Questo rende il nostro ombrellone Polo adatto all'uso professionale.

EN *The Polo umbrella can be made up of 1,2,3 or 4 umbrellas on one pole. Each umbrella can be assembled and used separately. So you can decide with great flexibility whether to have sun or shade. This makes our Polo parasol suitable for commercial use.*

FR *Le parasol Polo peut être composé de 1,2,3 ou 4 parasols sur un même mât. Chaque parasol peut être assemblé et utilisé séparément. Vous pouvez ainsi décider de manière très flexible si vous souhaitez profiter du soleil ou de l'ombre. Notre parasol Polo est donc adapté à un usage professionnel.*

DE *Der Polo-Sonnenschirm kann aus 1,2,3 oder 4 Sonnenschirmen an einem Mast bestehen. Jeder Regenschirm kann einzeln zusammengebaut und verwendet werden. So können Sie ganz flexibel entscheiden, ob Sie Sonne oder Schatten haben möchten. Dadurch ist unser Polo-Sonnenschirm für den professionellen Einsatz geeignet.*

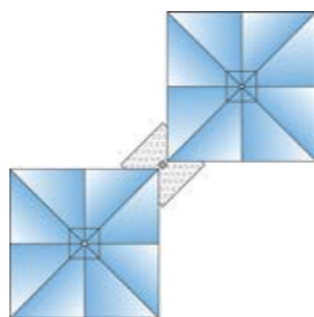

IT Possibile il montaggio contrapposto per P6-2 e P6-2 XL
EN *Opposite mounting possible for P6-2 and P6-2 XL*

FR *Montage opposé possible pour P6-2 et P6-2 XL*

DE *Gegenüberliegende Montage möglich für P6-2 und P6-2 XL*

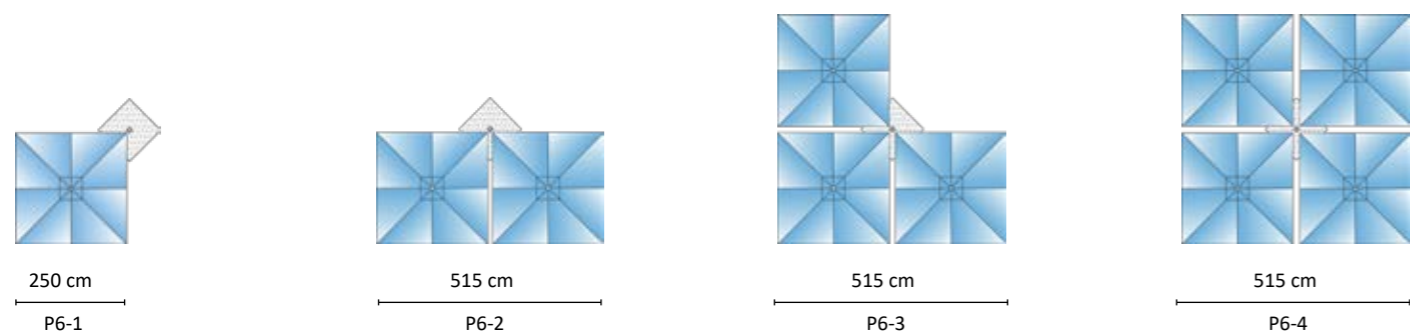

POLO XL

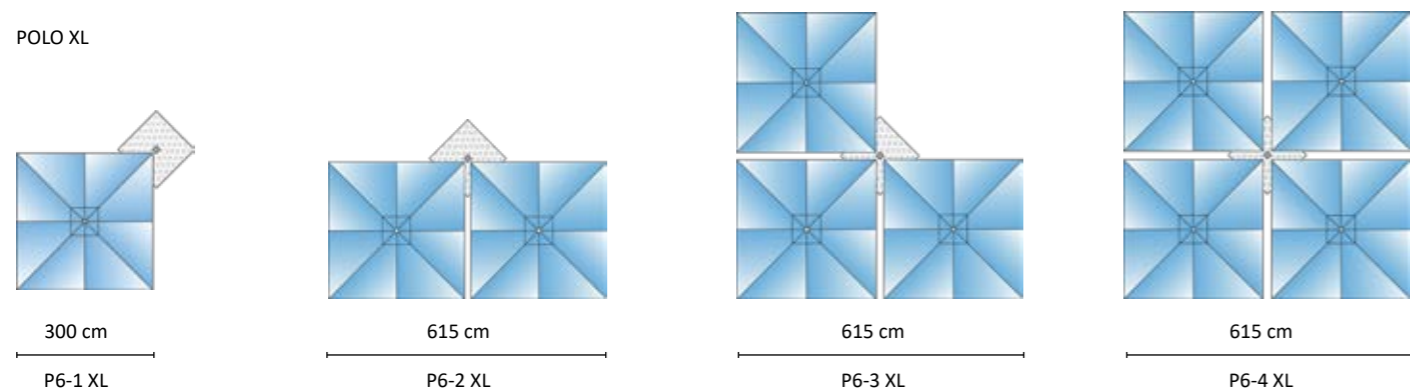

POLO RND

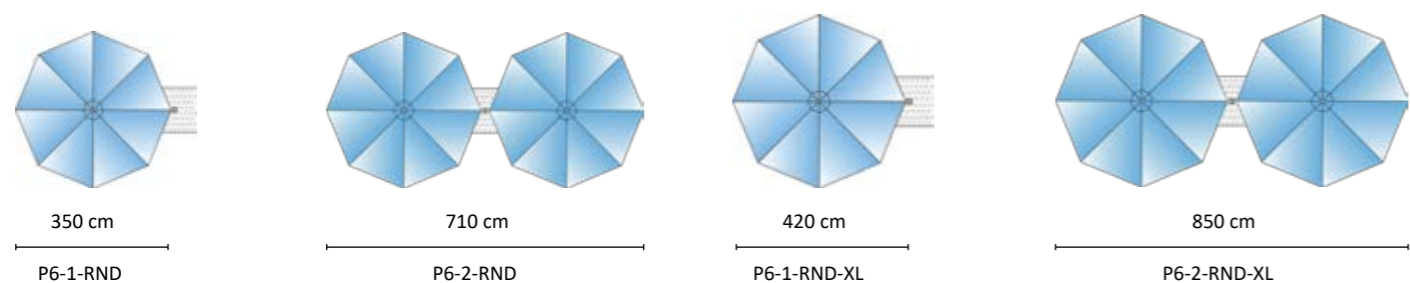

IT **COMBINAZIONI AGGANCI A MURO**
FR **COMBINAISONS AVEC FIXATION MURALE**

EN **WALL-MOUNTED SYSTEM**
DE **SYSTEM MIT WANDBEFESTIGUNG**

IT Il palo del Polo può essere attaccato al muro con 2 agganci. Questo permette l'uso dell'ombrellone senza l'ingombro della base. Non è possibile il fissaggio a muro per gli ombrelloni rotondi (RND).

EN *The Polo pole can be attached to the wall with 2 brackets. This allows for the use of the umbrella without the base taking up space. Wall mounting is not possible for round umbrellas (RND).*

FR *Le mât du Polo peut être fixé au mur avec 2 attaches. Cela permet l'utilisation du parasol sans l'encombrement de la base. La fixation murale n'est pas possible pour les parasols ronds (RND).*

DE *Der Pole kann mit 2 Halterungen an der Wand befestigt werden. Dies ermöglicht die Verwendung des Sonnenschirms ohne den Platzbedarf des Ständers. Eine Wandbefestigung ist für runde Sonnenschirme (RND) nicht möglich.*

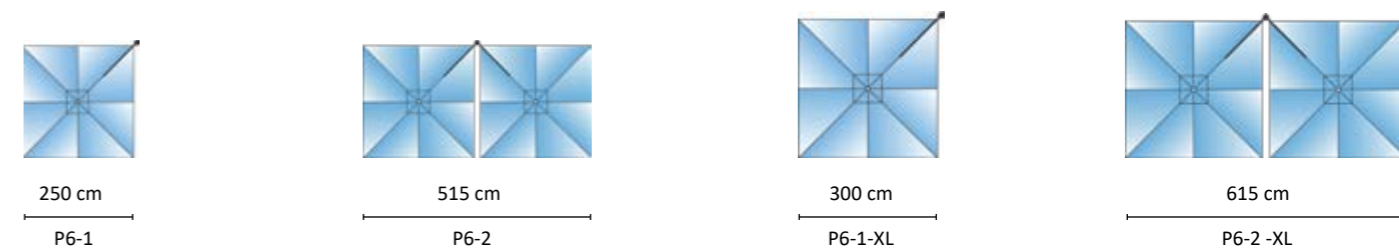

IT Tutti gli ombrelloni in tutte le combinazioni, chiudendosi, rientrano vicino al palo di sostegno

EN *All parasols in all combinations, when closing, retract near the support pole.*

FR *Tous les parasols, dans toutes les combinaisons, se replient près du mât de support lors de leur fermeture.*

DE *Alle Sonnenschirme in allen Kombinationen ziehen sich beim Schließen nah am Stützast ein.*



POLO

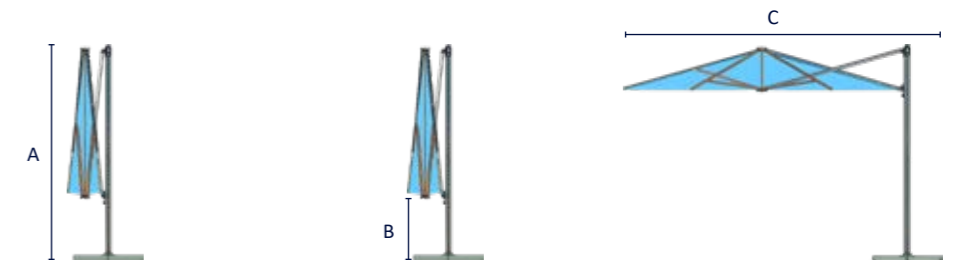

ART.	A	B	C
P6-1	271 cm	78 cm	335 cm
P6-1 XL	290 cm	65 cm	385 cm
P6-1-RND	271 cm	78 cm	435 cm
P6-1-RND-XL	295 cm	65 cm	505 cm

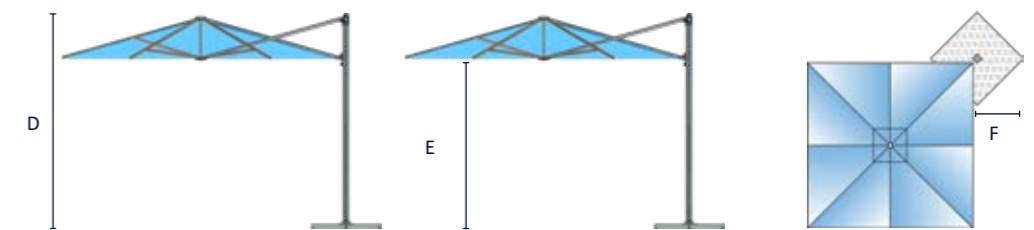

ART.	D	E	F
P6-1	281 cm	210 cm	85 cm
P6-1 XL	300 cm	225 cm	85 cm
P6-1-RND	275 cm	210 cm	56 cm
P6-1-RND-XL	300 cm	220 cm	56 cm

OPTIONAL



IT Luce a LED bianca e/o rgb.
 EN White and/or RGB LED light.
 FR Lumière LED blanche et/ou RGB.
 DE Weißes und/oder RGB-LED-Licht.



IT Batterie per Led.
 EN Batteries for Led.
 FR Batterie pour Led.
 DE Batterien für Led.



IT Riscaldatore ad infrarossi. Non deve essere smontato per chiudere l'ombrellone.
 EN Infrared heater. Must not be disassembled to close the umbrella.
 FR Chauffage infrarouge. Ne doit pas être démonté pour fermer le parasol.
 DE Infrarot-Heizung. Darf nicht demontiert werden, um den Sonnenschirm zu schließen.



IT Prese singole o multiple possono essere montate sul palo.
 EN Single or multiple sockets can be mounted on the pole.
 FR Prises simples ou multiples peuvent être montées sur le poteau.
 DE Einzelne oder doppelte Steckdosen können am Mast montiert werden.



IT Gli ombrelloni possono essere predisposti per le canaline, applicate con il velcro.
 EN The umbrellas can be prepared for the rain gutters, attached with Velcro.
 FR Les parasols peuvent être préparés pour les gouttières, fixés avec du velcro.
 DE Die Sonnenschirme können für die Regenrinnen vorbereitet und mit Klettverschluss befestigt werden.



IT Fodera di protezione Mytex impermeabile e traspirante.
 EN Mytex waterproof and breathable protective cover.
 FR Housse de protection en Mytex imperméable et respirante.
 DE Wasserdichtes und atmungsaktives Mytex-Schutzhülle.

POLO

IT **BASI, STAFFE ED ACCESSORI**
EN **BASES, HOOKS AND ACCESSORIES**

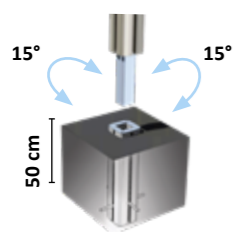

IT Base da interrare in acciaio zincato ed alluminio, regolabile fino a 15° di tolleranza a sinistra e a destra.
EN Galvanized steel and aluminium inground base adjustable up to 15° of tolerance left and right.
FR Pied à enterrer en acier zingué et aluminium, réglable jusqu'à 15° de tolérance à gauche et à droite.
DE Verzinkter Stahl- und Aluminium Sockel, einstellbar mit einer Toleranz von 15° nach rechts und links.

FR **PIEDS, CROCHETS ET ACCESSOIRES**
DE **FUSS, HALTERUNGEN UND ZUBEHÖRE**

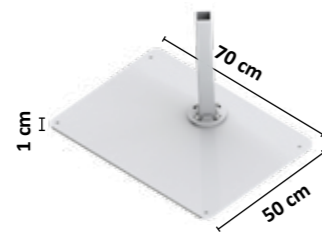

IT Piastra da pavimento decentrata; deve essere attaccata con colla chimica. Peso 30 kg.
EN Side floor plate; must be attached with chemical glue. Weight 30kg.
FR Plaque de sol déportée; doit être fixée avec de la colle chimique. Poids 30kg.
DE Seitlicher Bodenplatte; sie muss mit chemischem Kleber befestigt werden. Gewicht: 30 kg.

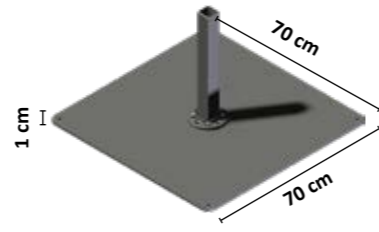

IT Piastra da pavimento; deve essere attaccata con colla chimica. Peso 38 kg.
EN Floor plate; must be attached with chemical glue. Weight 38kg.
FR Plaque de sol; doit être fixée avec de la colle chimique. Poids 38kg.
DE Bodenplatte; sie muss mit chemischem Kleber befestigt werden. Gewicht: 38 kg.

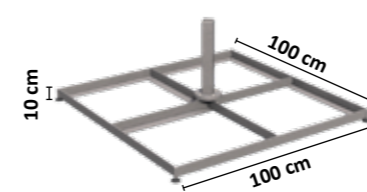

IT Base d'acciaio zincato. Non sono inclusi i contrappesi.
EN Galvanized steel base. Counterweights are not included.
FR Pied en acier zingué. Les contrepoids ne sont pas incluses.
DE Sockel aus verzinktem Stahl. Gegengewicht sind nicht im Lieferung enthalten.
Con/avec/with/mit 4: 105 kg
con/avec/with/mit 8: 185 kg



IT Copertura in alluminio per base acciaio zincato.
EN Aluminum cover for galvanized steel base.
FR Couverture en aluminium pour pied en acier zingué.
DE Aluminiumabdeckung für verzinkten Stahlsockel.



IT Set 4 ruote doppie con freni per base acciaio zincato.
EN Set of 4 double wheels with brakes for galvanized steel base.
FR Jeu de 4 roues doubles avec freins pour socle en acier zingué.
DE Set mit 4 Doppelrollen mit Bremsen für verzinktes Stahlgestell.

IT **FISSAGGIO A MURO**
EN **WALL FIXING**
FR **FIXATION MURALE**
DE **WANDBEFESTIGUNG**



IT Il palo del Polo può essere attaccato facilmente al muro con 2 agganci.
EN The pole of the Polo can be easily attached to the wall with 2 hooks.
FR Le mât du Polo peut être facilement fixé au mur grâce à 2 crochets.
DE Die Stange des Polo lässt sich einfach mit 2 Haken an der Wand befestigen.



POLO

IT TESSUTI - DATI TECNICI PAG. 144
EN FABRICS - TECHNICAL DATAS PAG.144

FR TISSUS - DONNÉES TECHNIQUES PAG. 144
DE STOFFE - TECHNISCHE DATEN PAG. 144

ACRILMA



SPECIAL ACRILMA

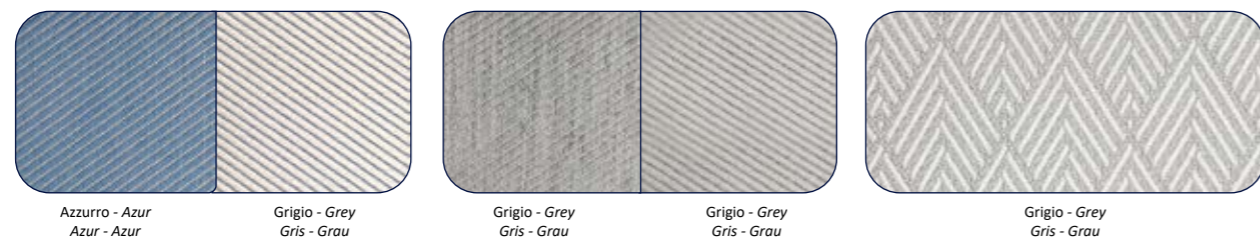

RAYTENT

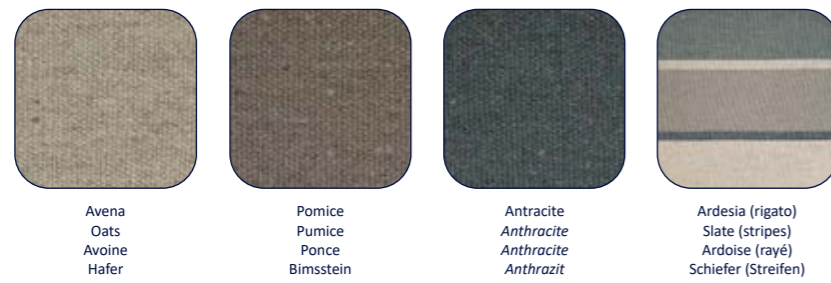

POOL *

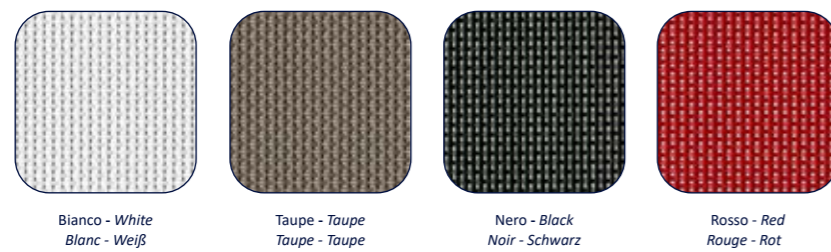

NAUTILUS *

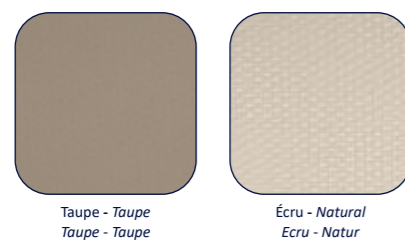

IT * Tessuto utilizzabile solo su versione P6 nella misura cm 250X250.

EN * Fabric available just for P6, size 250x250 cm.

FR * Tissu disponible seulement pour P6, taille 250x250 cm.

DE * Stoff nur verfügbar für P6, Größe 250x250 cm.



PRINCE



PRINCE

IT Ombrellone a palo laterale con apertura in 1 solo movimento. Può essere dotato di piedestallo o di ancoraggio a muro girevole, ottimale per essere attaccato sugli angoli. L'ombra può quindi essere regolata in qualunque momento della giornata.

EN Side pole parasol with "one movement" opening system. It can be equipped with a ground base or a turning wall anchor (ideal for use on the corners). The shade can therefore be adjusted at any time of the day.



IT Apertura manuale senza corde o manovelle.
EN Manual opening without ropes nor cranks.
FR Ouverture manuelle sans cordes ni manivelles.
DE Manuelles Öffnen ohne Seile oder Kurbeln.



IT Molla a gas per facilitare l'apertura.
EN Gas spring to facilitate opening.
FR Ressort à gaz pour faciliter l'ouverture.
DE Gasfeder erleichtert das Öffnen.



IT Bacchette alluminio mm 20x25.
EN Aluminium ribs 20x25 mm.
FR Baleines aluminium 20x25 mm.
DE Aluminium Streben 20x25 mm.

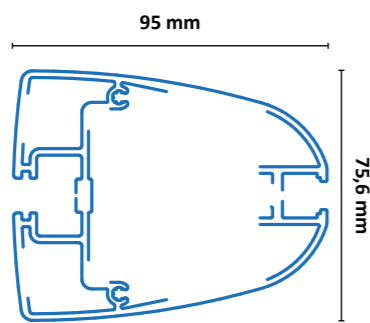

IT Palo mm 95x75 in alluminio.
EN Aluminium pole 95x75 mm.
FR Poteau en aluminium de 95x75 mm.
DE Aluminiummast 95x75 mm.



IT Colori: RAL 9016 – Bianco, RAL9005 - Nero.
FR Couleurs : RAL 9016 – Blanc, RAL9005 - Noir.
DE Farben: RAL 9016 – Weiß, RAL9005 – Schwarz.
EN Colours: RAL 9016 – White, RAL9005 - Black.



IT Colori: RAL 9007 – Grigio, Bronzo anodizzato
FR Couleurs : RAL 9007 – Gris, Bronze anodisé
DE Farben: RAL 9007 – Grau, eloxierte Bronze
EN Colours: RAL 9007 – Grey, Anodized Bronze

FR Parasol à mât déporté avec ouverture en 1 seul mouvement. Il peut être équipé d'un pied au sol ou d'un ancrage mural pivotant (idéal pour une fixation dans les angles). L'ombrage peut donc être réglé à tout moment de la journée.

DE Ampelschirm mit Öffnung in nur einer Bewegung. Es kann mit einem Standfuß oder einem drehbaren Wandanker (ideal zur Befestigung an Ecken) ausgestattet werden. Der Schatten kann daher zu jeder Tageszeit eingestellt werden.



PRINCE

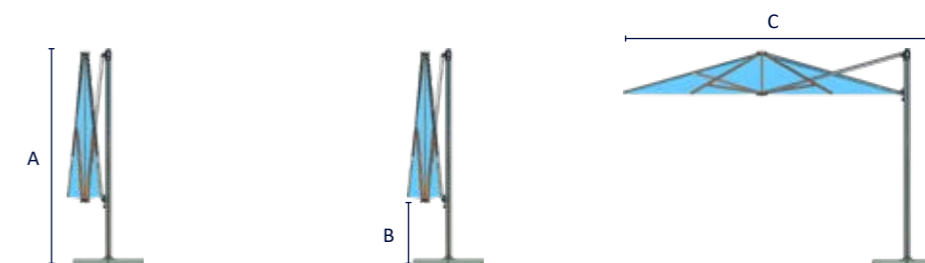
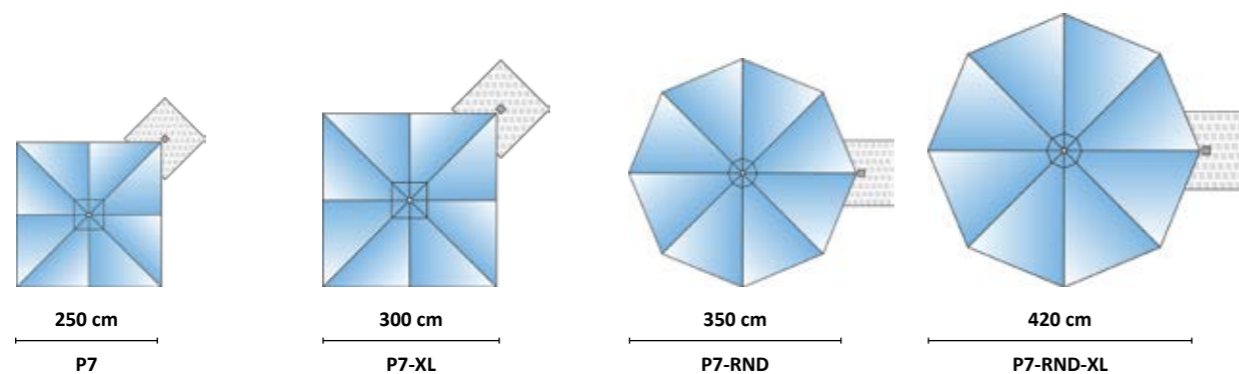

ART.	A	B	C
P7	271 cm	78 cm	335 cm
P7 XL	290 cm	65 cm	385 cm
P7-RND	271 cm	78 cm	435 cm
P7-RND-XL	295 cm	65 cm	505 cm

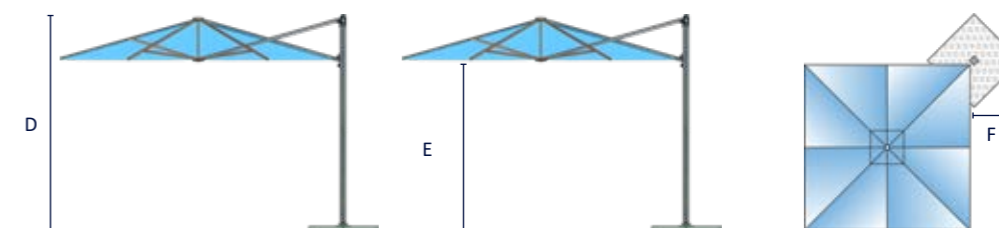

ART.	D	E	F
P7	281 cm	210 cm	85 cm
P7 XL	300 cm	225 cm	85 cm
P7-RND	275 cm	210 cm	56 cm
P7-RND-XL	300 cm	220 cm	56 cm

OPTIONAL



IT Luce a LED bianca e/o rgb.
 EN White and/or RGB LED light.
 FR Lumière LED blanche et/ou RGB.
 DE Weißes und/oder RGB-LED-Licht.



IT Batterie per Led.
 EN Batteries for Led.
 FR Batterie pour Led.
 DE Batterien für Led.



IT Riscaldatore ad infrarossi. Non deve essere smontato per chiudere l'ombrellone.
 EN Infrared heater. Must not be disassembled to close the umbrella.
 FR Chauffage infrarouge. Ne doit pas être démonté pour fermer le parasol.
 DE Infrarot-Heizung. Darf nicht demontiert werden, um den Sonnenschirm zu schließen.



IT Prese singole o multiple possono essere montate sul palo.
 EN Single or multiple sockets mounted on the pole.
 FR Prises simples ou multiples peuvent être montées sur le poteau.
 DE Einzelne oder doppelte Steckdosen können am Mast montiert werden.



IT Gli ombrelloni possono essere predisposti per le canaline, applicate con il velcro.
 EN The umbrellas can be prepared for the rain gutters, attached with Velcro.
 FR Les parasols peuvent être préparés pour les gouttières, fixés avec du velcro.
 DE Die Sonnenschirme können für die Regenrinnen vorbereitet und mit Klettverschluss befestigt werden.



IT Fodera di protezione Mytex impermeabile e traspirante.
 EN Mytex waterproof and breathable protective cover.
 FR Housse de protection en Mytex imperméable et respirante.
 DE Wasserdichtes und atmungsaktives Mytex-Schutzhülle.

PRINCE

IT BASI, STAFFE ED ACCESSORI
FR BASES, HOOKS AND ACCESSORIES

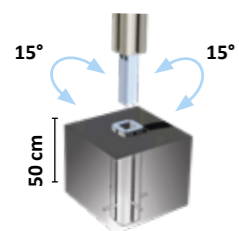

IT Base da interrare in acciaio zincato ed alluminio, regolabile fino a 15° di tolleranza a sinistra e a destra.

EN Galvanized steel and aluminium inground base adjustable up to 15° of tolerance left and right.

FR Pied à enterrer en acier zingué et aluminium, réglable jusqu'à 15° de tolérance à gauche et à droite.

DE Verzinkter Stahl- und Aluminium Sockel, einstellbar mit einer Toleranz von 15° nach rechts und links.

EN PIEDS, CROCHETS ET ACCESSOIRES
DE FUSS, HALTERUNGEN UND ZUBEHÖRE

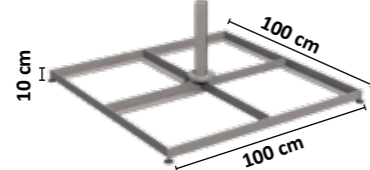

IT Base d'acciaio zincata. Non sono inclusi i contrappesi.
EN Galvanized steel base. Counterweights are not included.
FR Pied en acier zingué. Les contrepoids ne sont pas incluses.
DE Sockel aus verzinktem Stahl. Gegengewicht sind nicht im Lieferumfang enthalten.

Con/with/avec/mit 4: 105 kg
con/with/avec/mit 8: 185 kg

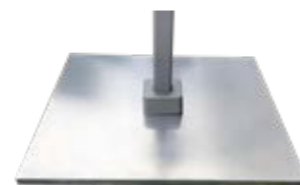

IT Copertura in alluminio per base acciaio zincata.
EN Aluminum cover for galvanized steel base.
FR Couverture en aluminium pour pied en acier zingué.
DE Aluminiumabdeckung für verzinkten Stahlsockel.

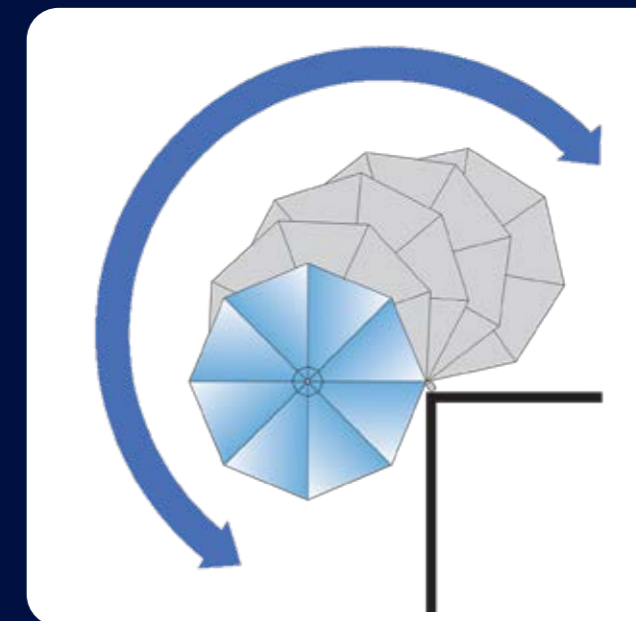
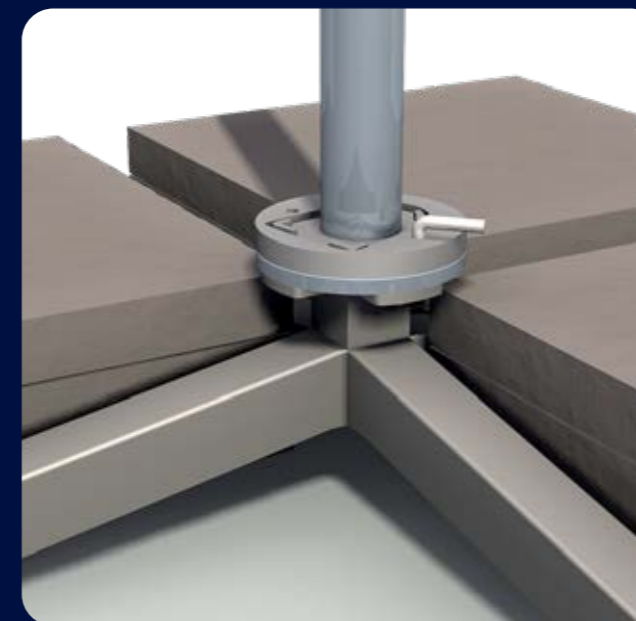

IT Prince ruota a 300° sia con base a terra, che con attacco a muro.
EN Prince rotates 300° both with a floor base and with a wall mount.
FR Prince tourne à 300° aussi bien avec un socle au sol qu'avec une fixation murale.
DE Prince dreht sich um 300° sowohl mit einem Ständer als auch mit einer Wandhalterung.

IT FISSAGGIO A MURO
EN WALL FIXING
FR FIXATION MURALE
DE WANDBEFESTIGUNG



IT Fissaggio a muro girevole. E' composto da due parti e permette l'uso anche sugli angoli, senza l'ingombro della base.

EN Turning wall system. It consists of two hooks and allows for use in corners as well, without the base taking up space.

FR Fixation murale pivotante. Il est composé de deux parties et permet également une utilisation dans les coins, sans l'encombrement du pied.

DE Drehbare Wandbefestigung. Sie besteht aus zwei Teilen und ermöglicht auch die Verwendung in Ecken, ohne den Platzbedarf einer Basis.



PRINCE

IT TESSUTI - DATI TECNICI PAG. 144
EN FABRICS - TECHNICAL DATAS PAG.144

FR TISSUS - DONNÉES TECHNIQUES PAG. 144
DE STOFFE - TECHNISCHE DATEN PAG. 144

ACRILMA



SPECIAL ACRILMA

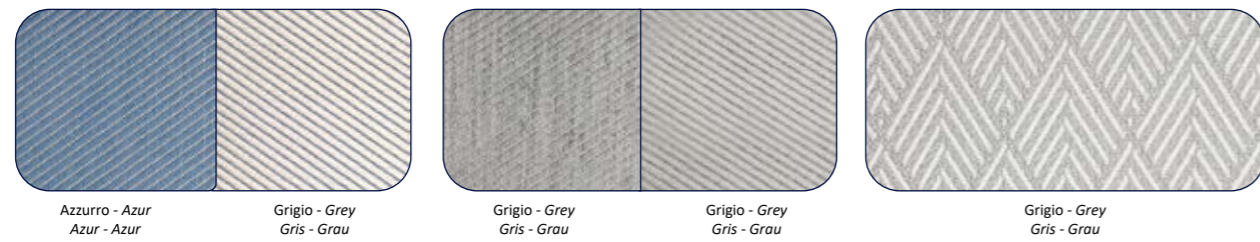

RAYTENT

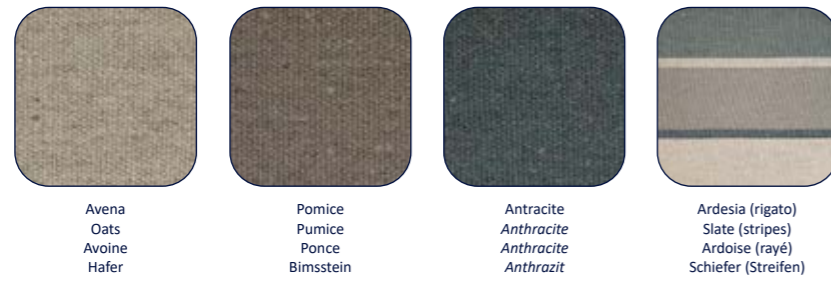

POOL *

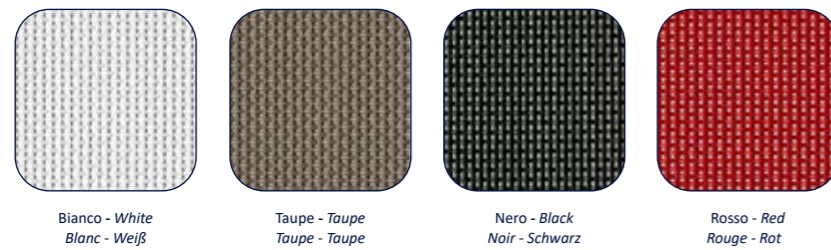

NAUTILUS *

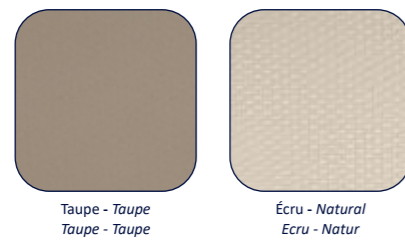

IT* Tessuto utilizzabile solo su versione P7 nella misura cm 250X250.

EN* Fabric available just for P7, size 250x250 cm.

FR* Tissu disponible seulement pour P7, taille 250x250 cm.

DE* Stoff nur verfügbar für P7, Größe 250x250 cm.



VIK

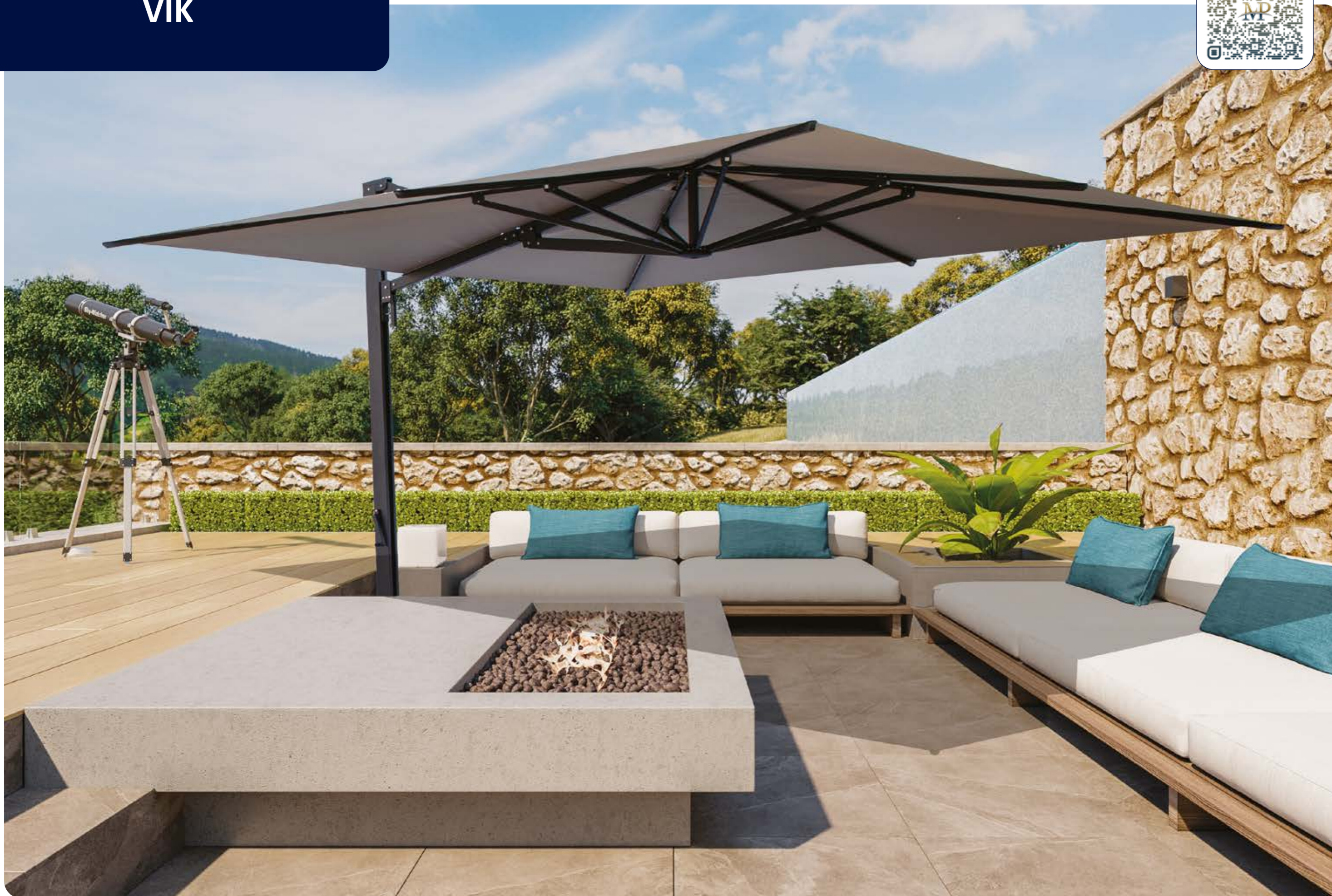

IT Ombrellone laterale retrattile in alluminio misura mt 4x4, girevole 360° e inclinabile, apertura con maniglione scorrevole e manovella, regolabile in 5 posizioni. Telaio colore grafite o platino.

EN Folding aluminum side umbrella, 360° rotating and tiltable, opening with a sliding handle and crank, adjustable in 5 positions. Colours for frame: graphite or platinum.



IT Palo in alluminio mm 105x70 con maniglia.
EN Aluminium pole 105x70 mm with handle.
FR Poteau en aluminium de 105x70 mm avec poignée.
DE Aluminiumstock 105x70 mm mit Griff.



IT Doppianoce alluminio.
EN Aluminium notch.
FR Noix en aluminium.
DE Nuss aus Aluminium.



IT Bacchette alluminio intercambiabili.
EN Replaceable aluminium ribs.
FR Baleines interchangeables en aluminium.
DE Austauschbaren Aluminiumschienen.



IT Apertura con manovella.
EN Opening with crank.
FR Ouverture avec manivelle.
DE Öffnung mit Kurbel.



IT Sistema di rotazione in alluminio.
EN Cast alu rotation system.
FR Système de rotation en alu.
DE Drehsystem aus Aluminium.

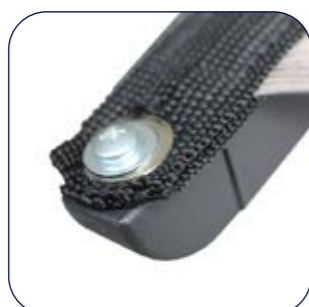

IT Aggancio tela.
EN Cover fixing.
FR Fixation toile.
DE Stoffbefestigung.

FR Parasol déporté rétractable en aluminium taille 4x4 mt, pivotant à 360° et inclinable, ouverture avec poignée coulissante et manivelle, réglable en 5 positions. Structure couleur graphite ou platine.

DE Klappbarer Aluminium-Ampelschirm, 360° drehbar und neigbar, Öffnung mit einem verschiebbaren Griff und Kurbel, in 5 Positionen verstellbar. Gestell erhältlich in Graphit- oder Platinfarbe.



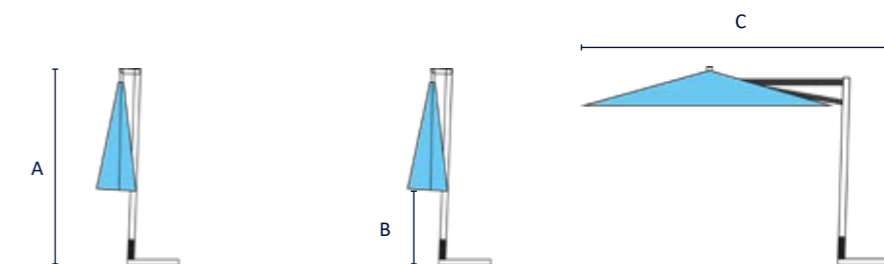
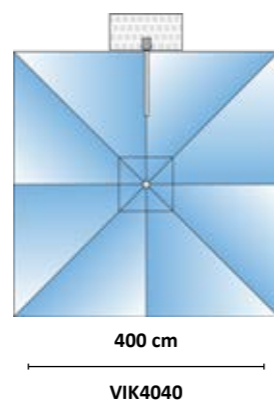

ART.	A	B	C
VIK4040P (platino, platinum, platine, Platin)	295 cm	13 cm	470 cm
VIK4040G (grafite, graphite, graphite, Graphit)	295 cm	13 cm	470 cm

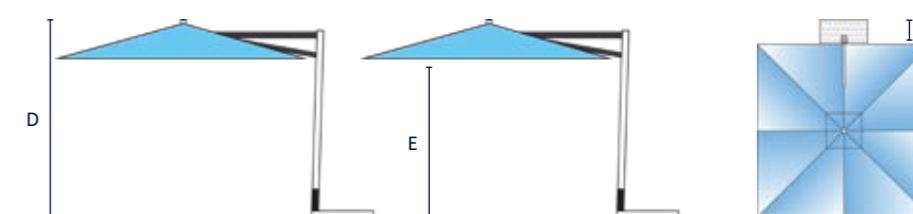

ART.	D	E	F
VIK4040P (platino, platinum, platine, Platin)	280 cm	230 cm	80 cm
VIK4040G (grafite, graphite, graphite, Graphit)	280 cm	230 cm	80 cm

OPTIONAL

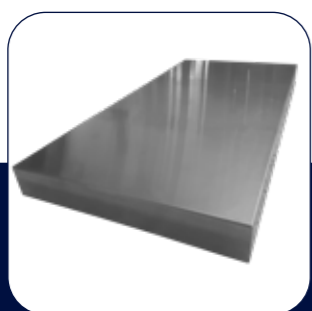

IT Base a T. Opzione: copertura in alluminio mandorlato.
 EN T base. Option: tread plate aluminum cover.
 FR Pied en T. Option: couverture en alu larmé.
 DE T-Fuß. . Optionale: Riffelblech Aluminiumabdeckung.



IT Base da interrare.
 EN Inground base.
 FR Pied à enterrer.
 DE Sockel.



IT Fodera di protezione Mytex.
 EN Mytex protection cover.
 FR Housse de protection en Mytex.
 DE Mytex Schutzhülle.



IT Riscaldatore ad infrarossi con supporto per stecca ombrellone.
 Disponibile in colore bianco e grafite.
 EN Infrared heater with hook for parasol rib. Available in white and graphite.
 FR Chauffage infrarouge avec crochet pour baleine parasol. Disponible en blanc et graphite.
 DE Infrarot Heizung with Hänger für Sonnenschirmschienen. Verfügbar in weiß oder Graphit.

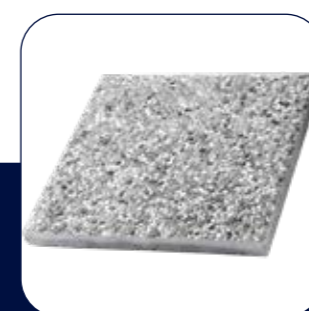

IT Piastre di contrappeso.
 EN Counterweight plates.
 FR Plaques de contreponds.
 DE Gegengewicht platten.



IT Personalizzazione tessuto.
 EN Advertising customization.
 FR Personnalisation publicitaire.
 DE Werbepersonalisierung.

ACRILMA

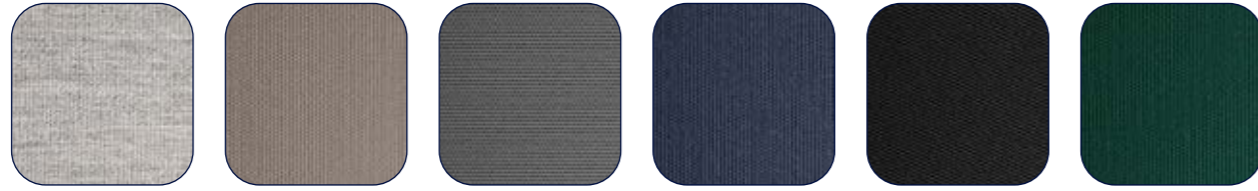

Piedra - Piedra
Piedra - Piedra

Taupe - Taupe
Taupe - Taupe

Antracite
Anthracite
Anthracite
Anthrazit

Blu - Blue
Bleu - Blau

Nero - Black
Noir - Schwarz

Verde - Green
Vert - Grün

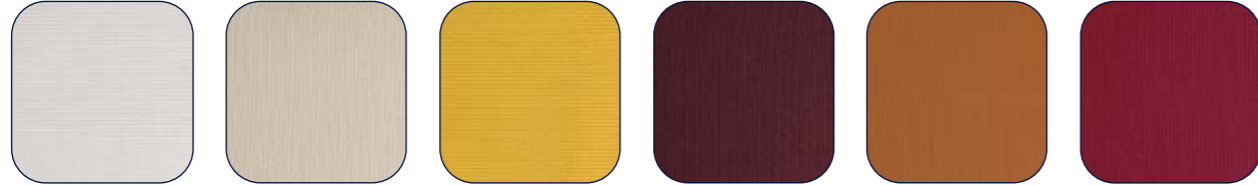

Bianco - White
Blanc - Weiß

Écru - Natural
Ecrú - Natur

Giallo - Yellow
Jaune - Gelb

Bordeaux
Burgundy
Bordeaux
Bordeaux

Terracotta
Terracotta
Terre cuite
Terracotta

Brasserie
Brasserie
Brasserie
Brasserie

SPECIAL ACRILMA



Azzurro - Azur
Azur - Azur

Grigio - Grey
Gris - Grau

Grigio - Grey
Gris - Grau

Grigio - Grey
Gris - Grau

Grigio - Grey
Gris - Grau

RAYTENT

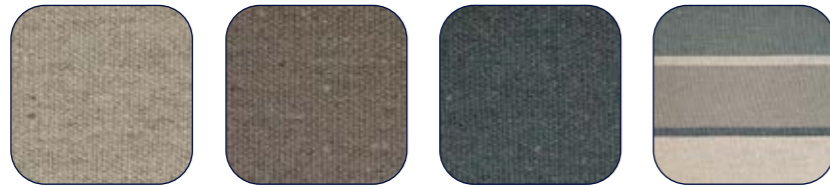

Avena
Oats
Avoine
Hafer

Pomice
Pumice
Ponce
Bimsstein

Antracite
Anthracite
Anthracite
Anthrazit

Ardesia (rigato)
Slate (stripes)
Ardoise (rayé)
Schiefer (Streifen)



URBAN



URBAN

IT Ombrellone Urban a palo laterale retrattile, girevole 360°, inclinabile. Disponibile nelle misure cm 300x300 e cm 300x400, viene offerto con 3 varianti di colore del telaio: platino, grafite e palo effetto legno.

EN Folding side pole parasol, turning 360°, tiltable. It's available in two sizes, 300x300, 300x400 and with the frame in three colourways: platinum, graphite, wooden effect pole.

FR Parasol déporté rétractable, pivotant à 360°, inclinable. Les tailles disponibles sont 300x300 cm, 300x400 cm et la structure est disponible en couleur platine, graphite ou avec poteau effet bois.

DE Ampelschirm Urban, um 360° drehbar, neigbar. Erhältlich in den Größen 300x300 cm und 300x400 cm, wird mit 3 Gestellfarbvarianten angeboten: Platin, Graphit und Holzeffektstock.



IT Palo mm 65x98 con manopola alluminio.
EN Pole 65x98 mm with aluminium handle.
FR Mât 65x98 mm avec poignée aluminium.
DE Stock 65x98 mm mit Aluminiumgriff.



IT Doppianoce alluminio.
EN Aluminium notch.
FR Noix en aluminium.
DE Nuss aus Aluminium.

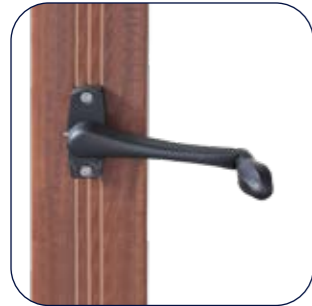

IT Manovella.
EN Crank.
FR Manivelle.
DE Kurbel.



IT Bacchette alluminio intercambiabili.
EN Replaceable aluminium ribs.
FR Baleines interchangeables en aluminium.
DE Austauschbaren Aluminiumschienen.



IT Base a T. Contrappesi non inclusi.
EN T base. Counterweights not included.
FR Pied en T. Contrepoids pas inclus.
DE T-Fuß. Gegengewicht nicht im Lieferung erhalten.



IT Sistema di rotazione in alluminio.
EN Cast alu rotation system.
FR Système de rotation en alu.
DE Drehsystem aus Aluminium.



URBAN

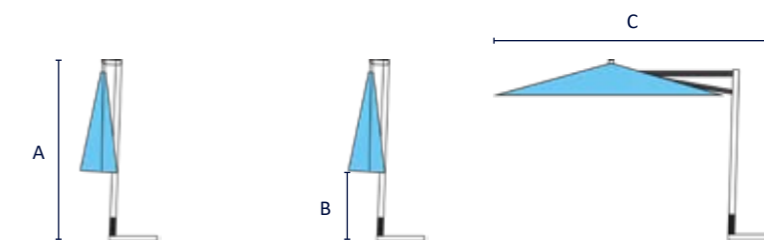
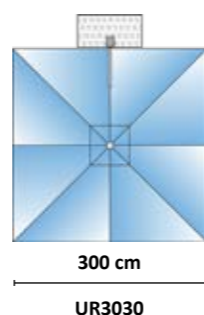
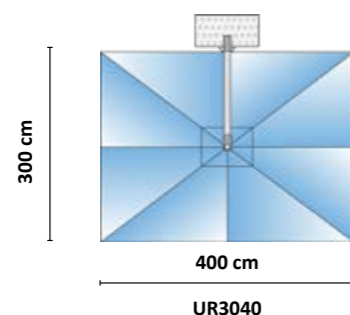

ART.	A	B	C
UR3030G (grafite, graphite, graphite, Graphit)	265 cm	50 cm	380 cm
UR3030P (platino, platinum, platine, Platin)	265 cm	50 cm	380 cm
UR3040G (grafite, graphite, graphite, Graphit)	270 cm	20 cm	380 cm
UR3040P (platino, platinum, platine, Platin)	270 cm	20 cm	380 cm
UR3040W (effetto legno, wood effect, effet bois, Holzeffekt)	270 cm	20 cm	380 cm

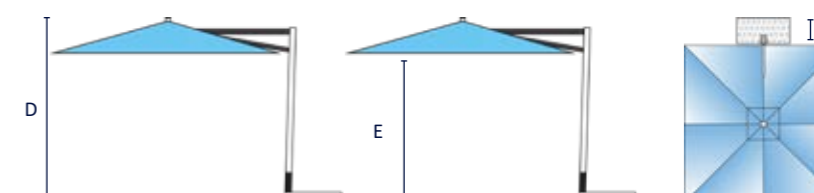

ART.	D	E	F
UR3030G (grafite, graphite, graphite, Graphit)	260 cm	210 cm	80 cm
UR3030P (platino, platinum, platine, Platin)	260 cm	210 cm	80 cm
UR3040G (grafite, graphite, graphite, Graphit)	265 cm	220 cm	80 cm
UR3040P (platino, platinum, platine, Platin)	265 cm	220 cm	80 cm
UR3040W (effetto legno, wood effect, effet bois, Holzeffekt)	265 cm	220 cm	80 cm

OPTIONAL

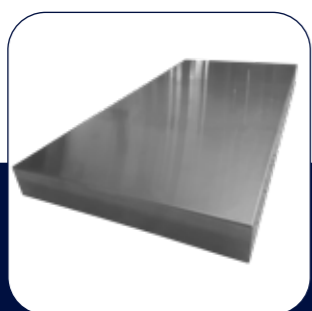

IT Base a T. Opzione: copertura in alluminio liscio o mandorlato.
 EN T base. Option: smooth or chequered alu cover.
 FR Pied en T. Option: couverture en alu lisse ou larmé.
 DE T-Fuß. Optionale: glattes oder riffelblech Aluminiumabdeckung.



IT Base da interrare.
 EN Inground base.
 FR Pied à enterrer.
 DE Sockel.



IT Fodera di protezione Mytex.
 EN Mytex protection cover.
 FR Housse de protection en Mytex.
 DE Mytex Schutzhülle.



IT Riscaldatore ad infrarossi con supporto per stecca ombrellone.
 Disponibile in colore bianco e grafite.
 EN Infrared heater with hook for parasol rib. Available in white and graphite.
 FR Chauffage infrarouge avec crochet pour baleine parasol. Disponible en blanc et graphite.
 DE Infrarot Heizung with Hänger für Sonnenschirmschienen. Verfügbar in weiß oder Graphit.

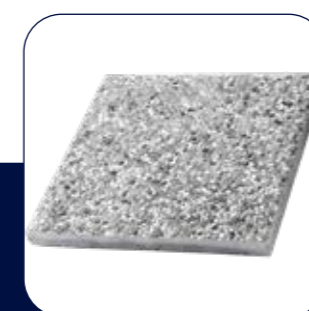

IT Piastre di contrappeso.
 EN Counterweight plates.
 FR Plaques de contrepoids.
 DE Gegengewicht platten.



IT Base in metallo con ruote.
 Composta da 3 piastre sovrapposte. Solo per cm 300x300.
 EN Metal base with wheel. Composed by 3 overlapped tiles. Only for 300x300 cm.
 FR Pied en métal avec roulettes. Composé par 3 dalles superposées. Seulement pour 300x300 cm.
 DE Metallständer mit Räder. Besteht auf 3 überlappenden Platten. Nur für 300x300 cm.

URBAN

IT TESSUTI - DATI TECNICI PAG. 144
EN FABRICS - TECHNICAL DATAS PAG.144

FR TISSUS - DONNÉES TECHNIQUES PAG. 144
DE STOFFE - TECHNISCHE DATEN PAG. 144

ACRILMA



SPECIAL ACRILMA

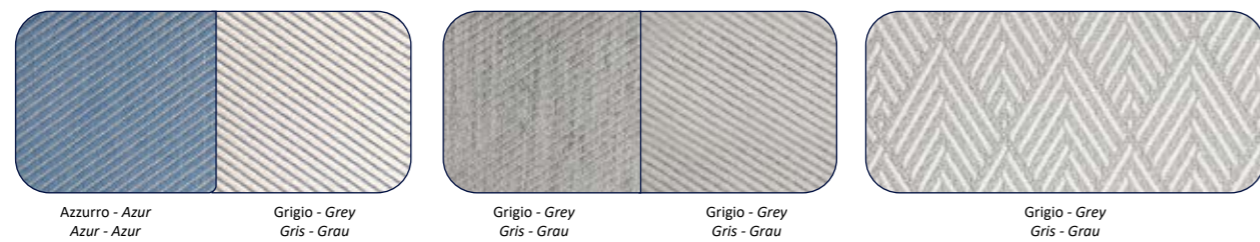

RAYTENT

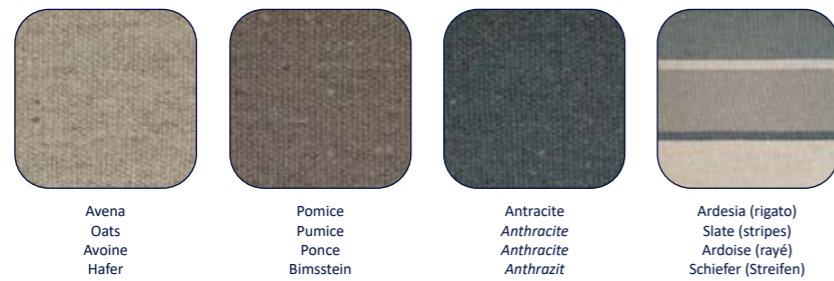

TEXMA*



IT*Colori Bianco, Écru, Taupe, Grigio, Brasserie, Blu consigliati su telaio platino perchè le finiture sono in tinta con il telaio.

Colori Écru, Taupe, Grigio, Terracotta, Antracite, Nero consigliati su telaio grafite perchè le finiture sono in tinta con il telaio.

EN* Colours white, natural, taupe, grey, brasserie, blue are standard for the platinum frame; cream, taupe, grey, terra, anthracite, black fits the graphite frame

FR* Les couleurs blanc, ecru, taupe, gris, brasserie, bleu sont standard pour la structure platine; ecru, taupe, gris, terra, anthracite, noir sont standard pour la structure graphite

DE* Die Farben Weiß, Natur, Taupe, Grau, Brasserie, Blau sind paßen für Platinumgestell; Natur, Taupe, Grau, Terra, Anthrazit, Schwartz paßen für Graphitgestell.



FIBRAPLUS



FIBRAPLUS

IT Ombrellone Fibraplus laterale a braccio fisso in fibra di vetro. La struttura in fibra di vetro conferisce resistenza, elasticità durata superiori a quelle offerte da legno o metallo; la fibra di vetro è un materiale composito in grado di assorbire le sollecitazioni improvvise.

EN Fibraplus is a fiberglass cantilever parasol. The fiberglass frame gives much more strength, elasticity and long lasting than wood or metal; the fiberglass is a composite material able to absorb sudden stress.

FR Parasol déporté à bras fixe en fibre de verre. La structure en fibre de verre donne résistance, élasticité et durée supérieures au bois ou métal; la fibre de verre est un matériel composite capable d'absorber la pression soudaine du vent.

DE Glasfaser Ampleschirm mit festem Arm. Das Gestell aus Glasfaser hat hoher Festigkeit, Flexibilität und Dauer als Holz oder Metall; Glasfaser ist a Verbundmaterial und kann plötzliche Krafteinwirkungen absorbieren.



IT Struttura interna.
EN Inside frame.
FR Structure intérieure.
DE Innenstruktur.



IT Bacchette in fibra di vetro intercambiabili.
EN Exchangeable fiberglass ribs.
FR Baleines fibre de verre interchangeables.
DE Austauschbare Streben aus Glasfaser.



IT Stabilizzatore.
EN Stabilizer.
FR Stabilisateur.
DE Stabilisator.

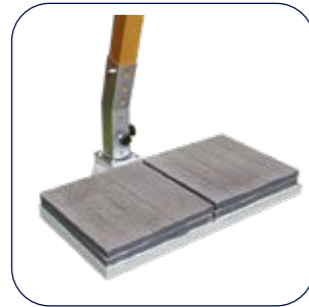

IT Base a T.
EN T base.
FR Pied en T.
DE T-Fuß.



IT Pali in fibra di vetro mm 91x91, connettori in acciaio verniciato.
EN Fiberglass poles 91x91 mm, coated steel connectors.
FR Poteaux en fibre de verre 91x91 mm, connecteurs en acier verni.
DE Stöcke aus Glasfaser 91x91 mm, lackierte Stahlverbinder.



IT Manovella in alluminio con cavo inox.
EN Alu crank with s/s cable.
FR Manivelle alu avec cable acier inox.
DE Aluseilwinde mit Edehstahlseil.



FIBRAPLUS

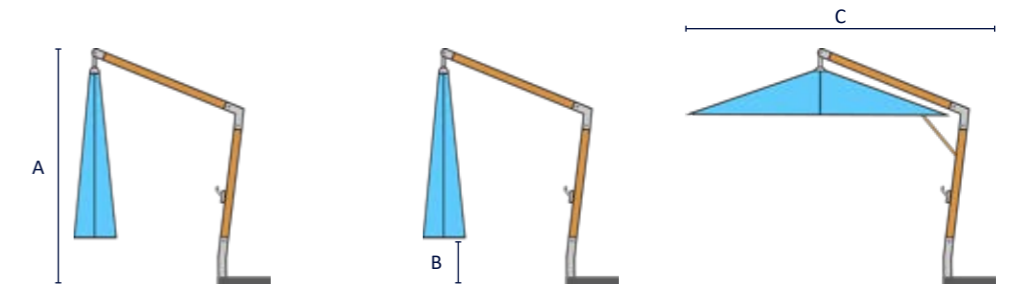
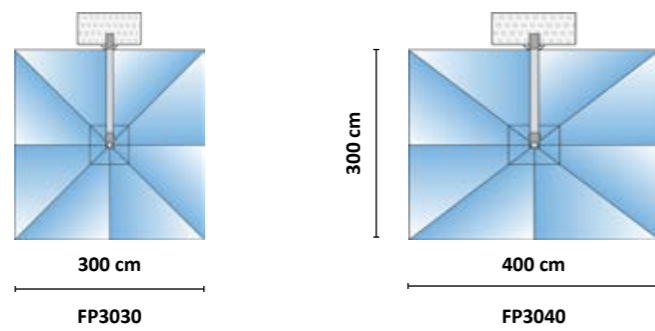

ART.	A	B	C
FP3030W	340 cm	80 cm	365 cm
FP3040W	340 cm	35 cm	365 cm

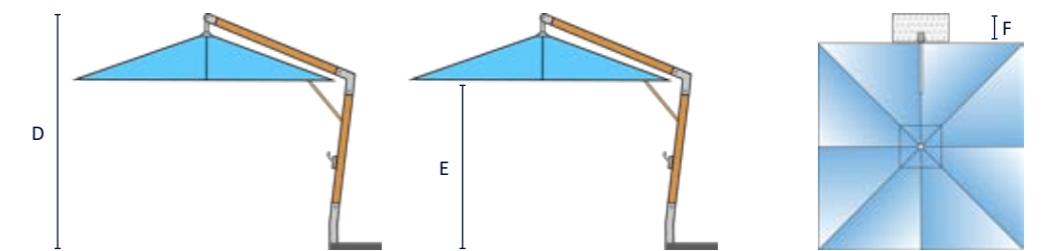

ART.	D	E	F
FP3030W	340 cm	240 cm	65 cm
FP3040W	340 cm	230 cm	65 cm

OPTIONAL

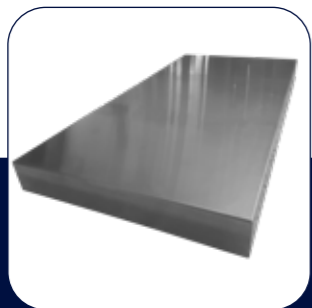

IT Base a T. Opzione: copertura in alluminio liscio o mandorlato.
 EN T base. Option: smooth or chequered alu cover.
 FR Pied en T. Option: couverture en alu lisse ou larmé.
 DE T-Fuß. Optionale: glattes oder riffelblech Aluminiumabdeckung.



IT Base da interrare.
 EN Inground base.
 FR Pied à enterrer.
 DE Sockel.



IT Fodera di protezione Mytex.
 EN Mytex protection cover.
 FR Housse de protection en Mytex.
 DE Mytex Schutzhülle.



IT Riscaldatore ad infrarossi con supporto per stecca ombrellone.
 EN Infrared heater with hook for parasol rib. Available in white and graphite.
 FR Chauffage infrarouge avec crochet pour baleine parasol. Disponible en blanc et graphite.
 DE Infrarot Heizung with Hänger für Sonnenschirmschienen. Verfügbar in weiß oder Graphit.

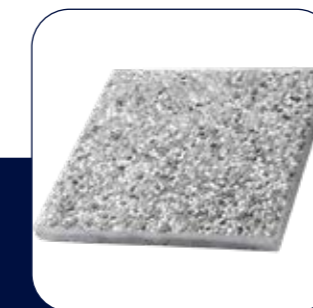

IT Piastre di contrappeso.
 EN Counterweight plates.
 FR Plaques de contrepoids.
 DE Gegengewicht platten.



IT Personalizzazione tessuto.
 EN Advertising customization.
 FR Personnalisation publicitaire.
 DE Werbepersonalisierung.

FIBRAPLUS

IT TESSUTI - DATI TECNICI PAG. 144
EN FABRICS - TECHNICAL DATAS PAG.144

FR TISSUS - DONNÉES TECHNIQUES PAG. 144
DE STOFFE - TECHNISCHE DATEN PAG. 144

ACRILMA

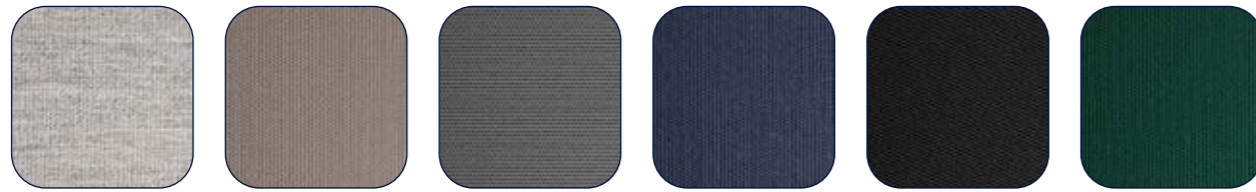

Piedra - Piedra
Piedra - Piedra

Taupe - Taupe
Taupe - Taupe

Antracite
Anthracite
Anthracite
Anthrazit

Blu - Blue
Bleu - Blau

Nero - Black
Noir - Schwarz

Verde - Green
Vert - Grün

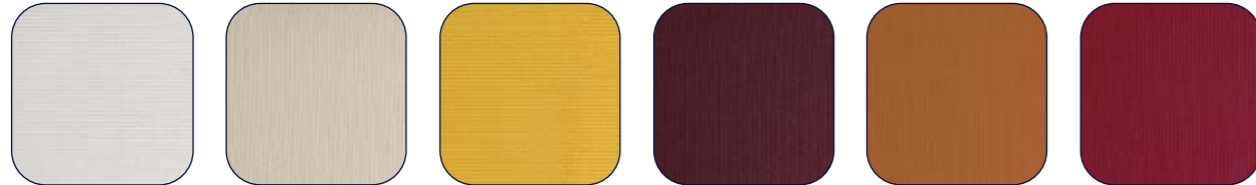

Bianco - White
Blanc - Weiß

Écru - Natural
Ecrú - Natur

Giallo - Yellow
Jaune - Gelb

Bordeaux
Burgundy
Bordeaux
Bordeaux

Terracotta
Terracotta
Terrecuite
Terracotta

Brasserie
Brasserie
Brasserie
Brasserie

SPECIAL ACRILMA

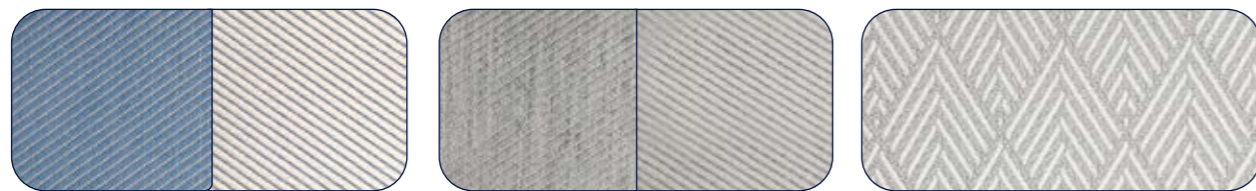

Azzurro - Azur
Azur - Azur

Grigio - Grey
Gris - Grau

Grigio - Grey
Gris - Grau

Grigio - Grey
Gris - Grau

Grigio - Grey
Gris - Grau

RAYTENT

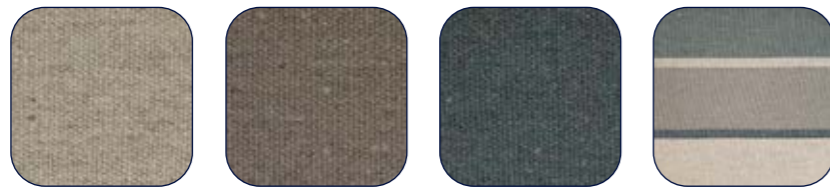

Avena
Oats
Avoine
Hafer

Pomice
Pumice
Ponce
Bimsstein

Antracite
Anthracite
Anthracite
Anthrazit

Ardesia (rigato)
Slate (stripes)
Ardoise (rayé)
Schiefer (Streifen)

DRALON



Bianco - White
Blanc - Weiß

Écru - Natural
Ecrú - Natur



JAMES T



JAMES T

IT Ombrellone telescopico in alluminio; il movimento telescopico permette all'ombrellone di aprirsi e chiudersi al di sopra di tavoli o arredi sottostanti.

EN Aluminium telescopic parasol; the telescopic movement allows the parasol to open and close above tables or furniture underneath.



IT Struttura alluminio.
EN Aluminium frame.
FR Structure aluminium.
DE Alugestell.



IT Collano in alluminio.
EN Aluminium runner.
FR Coulan aluminium.
DE Schieber aus Aluminium.



IT Bacchette alluminio smontabili.
EN Exchangeable aluminium ribs.
FR Beelines aluminium démontables.
DE Austauschbare Schienen aus Aluminium.

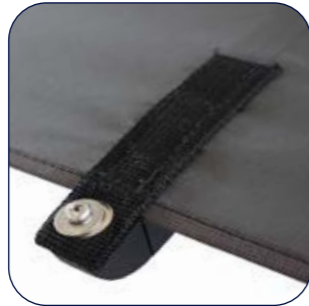

IT Aggancio tela.
EN Cover fixing.
FR Fixation toile.
DE Stoffbefestigung.



IT Palo mm 60 con manopola alluminio.
EN Pole 60 mm with aluminium handle.
FR Mât 60 mm avec poignée aluminium.
DE Stock 60 mm mit Aluminiumgriff.



IT Doppianoce in alluminio.
EN Aluminium hub.
FR Noix aluminium.
DE Nuss aus Aluminium.

FR Parasol télescopique en aluminium; le mouvement télescopique permet au parasol de s'ouvrir et de se fermer au-dessus des tables ou des meubles situés en-dessous.

DE Sonnenschirm mit telescopischem Aluminiumgestell. Die telescopische Bewegung ermöglicht es dem Sonnenschirm, sich über Tischen oder Möbeln darunter zu öffnen und zu schließen.



JAMES T

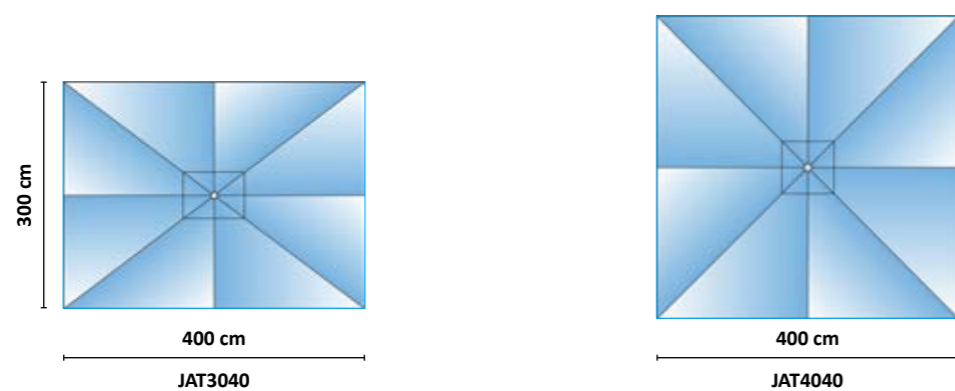

ART.	A	B
JAT3040G	360 cm	96 cm
JAT4040G	380 cm	87 cm

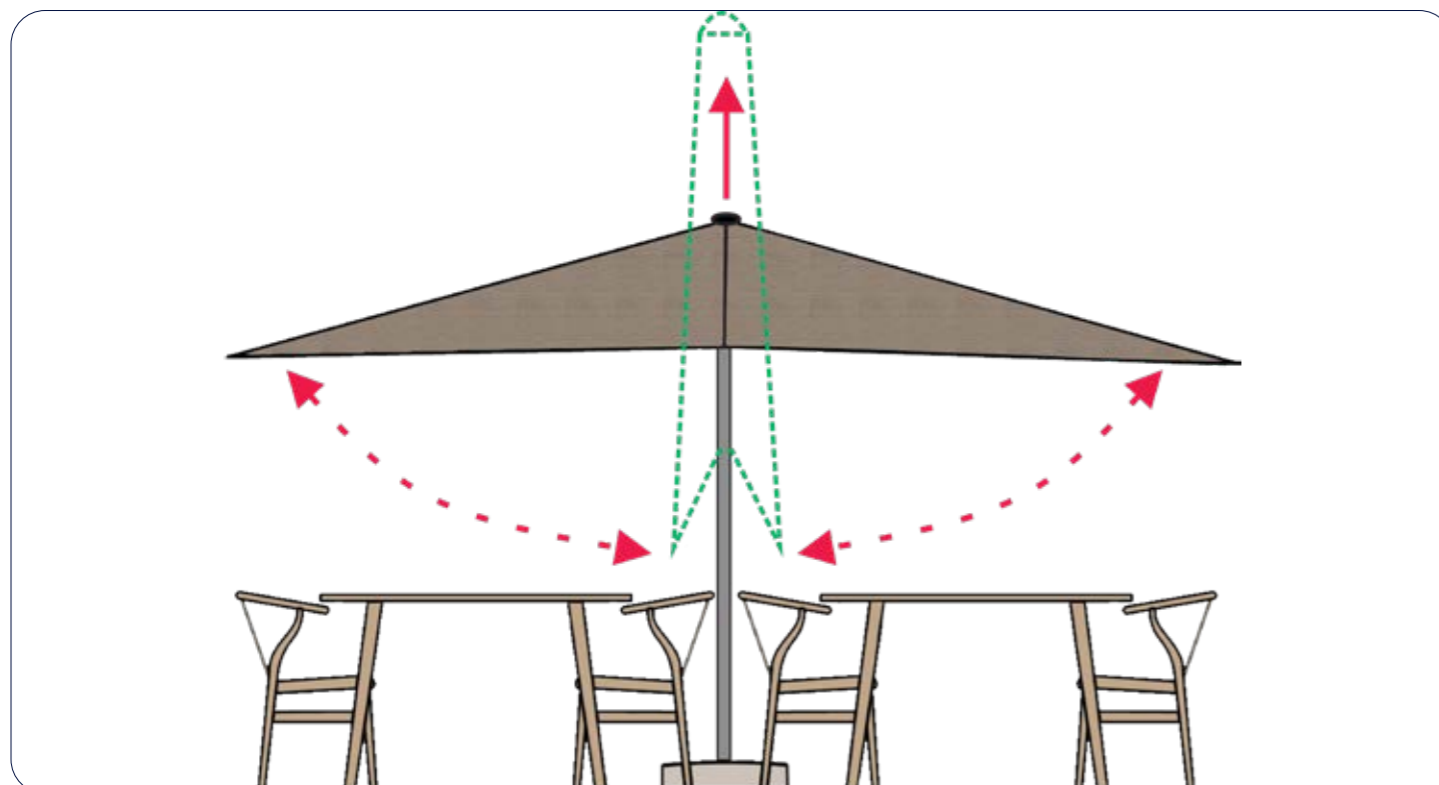

ART.	C	D
JAT3040G	290 cm	230 cm
JAT4040G	290 cm	230 cm

OPTIONAL

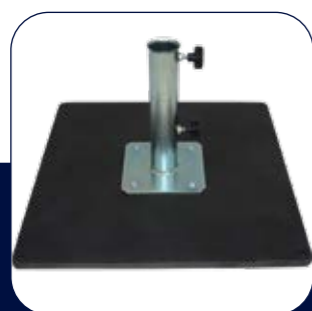

IT Art. 356X-GRA. Base metallica calpestabile, colore grafite.
 EN Art. 356X-GRA. Flat metal base, graphite colour.
 FR Art. 356X-GRA. Plaque en métal, couleur: graphite.
 DE Art. 356X-GRA. Metallständer farbe Graphit.



IT Art. 311-65. Base in graniglia con maniglie. Ø cm 65 - kg 75.
 EN Article 311-65. Grit base with handles. Ø 65 cm - 75 kg.
 FR Article 311-65. Pied en grès avec poignées. Ø 65 cm - 75 kg.
 DE Artikel 311-65. Betonständer mit Griffen. Ø 65 cm - 75 kg.

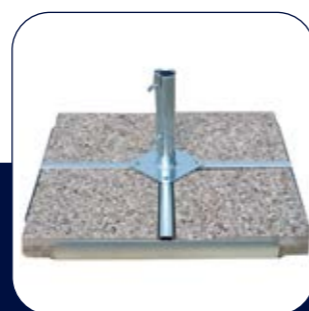

IT Art 341 cm 90x90. Base in ferro zincato per mattonelle.,cm 40x40 (fino ad 8 mattonelle).
 EN Art 341 cm 90x90. Galvanised steel base for slates 40x40 cm (till 8 slates).
 FR Art 341 cm 90x90. Pied en fer zingué pour dalles 40x40 cm (jusqu'à 8 dalles).
 DE Art 341 cm 90x90. Verzinkter Eisensockel für Fliesen, 40x40 cm (bis zu 8 Fliesen).



IT Gli ombrelloni possono essere predisposti per le canaline, applicate con il velcro.
 EN The umbrellas can be prepared for the rain gutters, attached with Velcro.
 FR Les parasols peuvent être préparés pour les gouttières, fixées avec du velcro.
 DE Die Sonnenschirme können für die Regenrinnen vorbereitet und mit Klettverschluss befestigt werden.



IT Fodera di protezione Mytex.
 EN Mytex protection cover.
 FR Housse de protection en Mytex.
 DE Mytex Schutzhülle.



IT Riscaldatore ad infrarossi con supporto per stecca ombrellone. Disponibile in colore bianco e grafite.
 EN Infrared heater with hook for parasol rib. Available in white and graphite.
 FR Chauffage infrarouge avec crochet pour baleine parasol. Disponible en blanc et graphite.
 DE Infrarot Heizung with Hänger für Sonnenschirmschienen. Verfügbar in weiß oder Graphit.

JAMES T

IT TESSUTI - DATI TECNICI PAG. 144
EN FABRICS - TECHNICAL DATAS PAG.144

FR TISSUS - DONNÉES TECHNIQUES PAG. 144
DE STOFFE - TECHNISCHE DATEN PAG. 144

ACRILMA

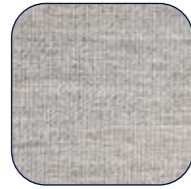

Piedra - Piedra
Piedra - Piedra



Taupe - Taupe
Taupe - Taupe

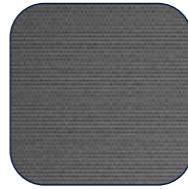

Antracite
Anthracite
Anthracite
Anthrazit



Blu - Blue
Bleu - Bleu



Nero - Black
Noir - Schwarz



Verde - Green
Vert - Grün



Bianco - White
Blanc - Weiß



Écru - Natural
Ecrú - Natur

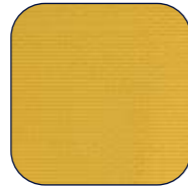

Giallo - Yellow
Jaune - Gelb



Bordeaux
Burgundy
Bordeaux
Bordeaux

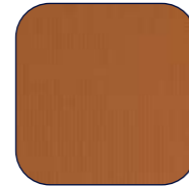

Terracotta
Terracotta
Terrecuite
Terracotta

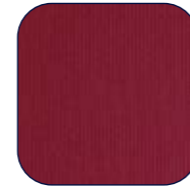

Brasserie
Brasserie
Brasserie
Brasserie

RAYTENT



Avena
Oats
Avoine
Hafer



Pomice
Pumice
Ponce
Bimsstein



Antracite
Anthracite
Anthracite
Anthrazit

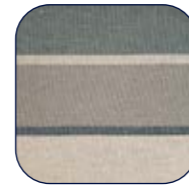

Ardesia (rigato)
Slate (stripes)
Ardoise (rayé)
Schiefer (Streifen)

DRALON



Bianco - White
Blanc - Weiß



Écru - Natural
Ecrú - Natur



FIBRAMAX



FIBRAMAX

IT Ombrellone a palo centrale con struttura in fibra di vetro. La struttura in fibra di vetro conferisce resistenza, elasticità durata superiori a quelle offerte da legno o metallo; la fibra di vetro è un materiale composito in grado di assorbire le sollecitazioni improvvise.

EN The fiberglass frame gives much more strength, elasticity and long lasting than wood or metal; the fiberglass is a composite material able to absorb sudden stress.



IT Collano versione colore teak, palo mm 48.

EN Teak colour version runner, pole 48 mm.

FR Coulan version couleur teak, mât 48 mm.

DE Schieber für die Teakfarbene Version, Stock 48 mm.



IT Struttura interna versione teak.

EN Teak colour inside frame.

FR Structure intérieure version teak.

DE Innenstruktur Teakfarbene Version.



IT Collano versione silver, palo mm 48.

EN Silver version runner, pole 48 mm.

FR Coulan version silver, mât 48 mm.

DE Schieber silberfarbene version, stock 48 mm.



IT Struttura interna colore silver.

EN Silver colour inside frame.

FR Structure intérieure version silver.

DE Innenstruktur Silberfarbene Version.



IT Collano versione grafite, palo mm 48.

EN Graphite version runner, pole 48 mm.

FR Coulan version Graphite, mât 48 mm.

DE Schieber Graphitfarbene version, stock 48 mm.



IT Struttura interna colore grafite.

EN Graphite colour inside frame.

FR Structure intérieure version Graphite.

DE Innenstruktur Graphitfarbene Version.

FR Parasol à mât central avec structure en fibre de verre. La structure en fibre de verre donne résistance, élasticité et durée supérieures au bois ou métal; la fibre de verre est un matériel composite capable d'absorber la pression soudaine du vent.

DE Sonnenschirm aus Glasfaser mit Mittelstock. Das Gestell aus Glasfaser hat hoher Festigkeit, Flexibilität und Dauer als Holz oder Metall; Glasfaser ist a Verbundmaterial und kann Plötzliche Kräfteinwirkungen absorbieren.



FIBRAMAX

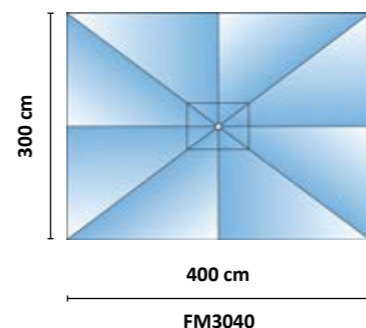
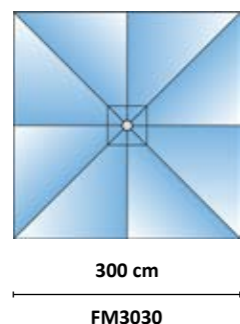

ART.	A	B
FM3030W	280 cm	53 cm
FM3030S	280 cm	53 cm
FM3030G	290 cm	53 cm
FM3040W	290 cm	25 cm
FM3040S	290 cm	25 cm
FM3040G	290 cm	25 cm



ART.	C	D
FM3030W	280 cm	220 cm
FM3030S	280 cm	220 cm
FM3030G	280 cm	220 cm
FM3040W	290 cm	220 cm
FM3040S	290 cm	220 cm
FM3040G	290 cm	220 cm

OPTIONAL

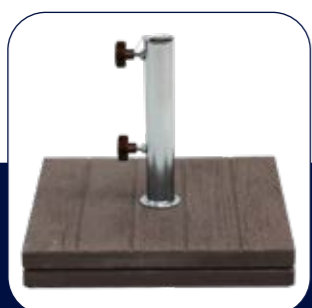

IT Art. 304X-MA. Base in cemento disegno legno, color marrone.
 EN Art. 304X-MA. Concrete base with wood design, brown colour.
 FR Art. 304X-MA. Pied en béton effet bois, couleur marron.
 DE Art. 304X-MA. Betonplattenständer mit Holzdesign, Farbe braun.

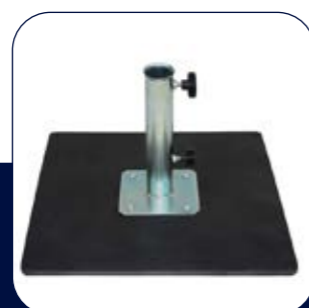

IT Art. 356X-GRA. Base metallica calpestabile, colore grafite.
 EN Art. 356X-GRA. Flat metal base, graphite colour.
 FR Art. 356X-GRA. Plaque en métal, couleur: graphite.
 DE Art. 356X-GRA. Metallständer, farbe Graphit.



IT Art. 311-55. Base in graniglia con maniglie. Ø 59 - kg 55.
 EN Article 311-55. Grit base with handles. Ø 59 cm - 55 kg.
 FR Article 311-55. Pied en grès avec poignées. Ø 59 cm - 55 kg.
 DE Artikel 311-55. Betonständer mit Griffen. Ø 59 cm - 55 kg.



IT Art. 356 Base piastra con route (optional).
 EN Art. 356 Flat base w/wheels (option).
 FR Art. 356 Plaque metal avec roulettes (option).
 DE Art. 356 Stahlständer mit Räder (option).



IT Fodera di protezione Mytex.
 EN Mytex protection cover.
 FR Housse de protection en Mytex.
 DE Mytex Schutzhülle.



IT Riscaldatore ad infrarossi con supporto per stecca ombrellone. Disponibile in colore bianco e grafite.
 EN Infrared heater with hook for parasol rib. Available in white and graphite.
 FR Chauffage infrarouge avec crochet pour baleine parasol. Disponible en blanc et graphite.
 DE Infrarot Heizung with Hänger für Sonnenschirmschienen. Verfügbar in weiß oder Graphit.

FIBRAMAX

IT TESSUTI - DATI TECNICI PAG. 144
EN FABRICS - TECHNICAL DATAS PAG.144

FR TISSUS - DONNÉES TECHNIQUES PAG. 144
DE STOFFE - TECHNISCHE DATEN PAG. 144

ACRILMA

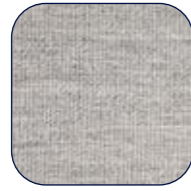

Piedra - Piedra
Piedra - Piedra



Taupe - Taupe
Taupe - Taupe



Antracite
Anthracite
Anthracite
Anthrazit



Blu - Blue
Bleu - Blau



Nero - Black
Noir - Schwarz



Verde - Green
Vert - Grün

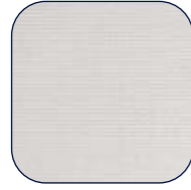

Bianco - White
Blanc - Weiß



Écru - Natural
Ecrú - Natur



Giallo - Yellow
Jaune - Gelb



Bordeaux
Burgundy
Bordeaux
Bordeaux

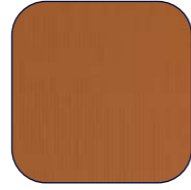

Terracotta
Terracotta
Terrecuite
Terracotta



Brasserie
Brasserie
Brasserie
Brasserie

RAYTENT



Avena
Oats
Avoine
Hafer



Pomice
Pumice
Ponce
Bimsstein



Antracite
Anthracite
Anthracite
Anthrazit



Ardesia (rigato)
Slate (stripes)
Ardoise (rayé)
Schiefer (Streifen)

DRALON*

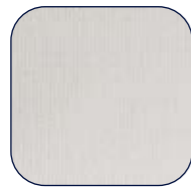

Bianco - White
Blanc - Weiß



Écru - Natural
Ecrú - Natur

IT* Solo per versione G (Grafite).

EN* For version G (Graphite) only.

FR* Seulement pour version graphite (G).

DE* Nur verfügbar für Graphitfarbene (G).

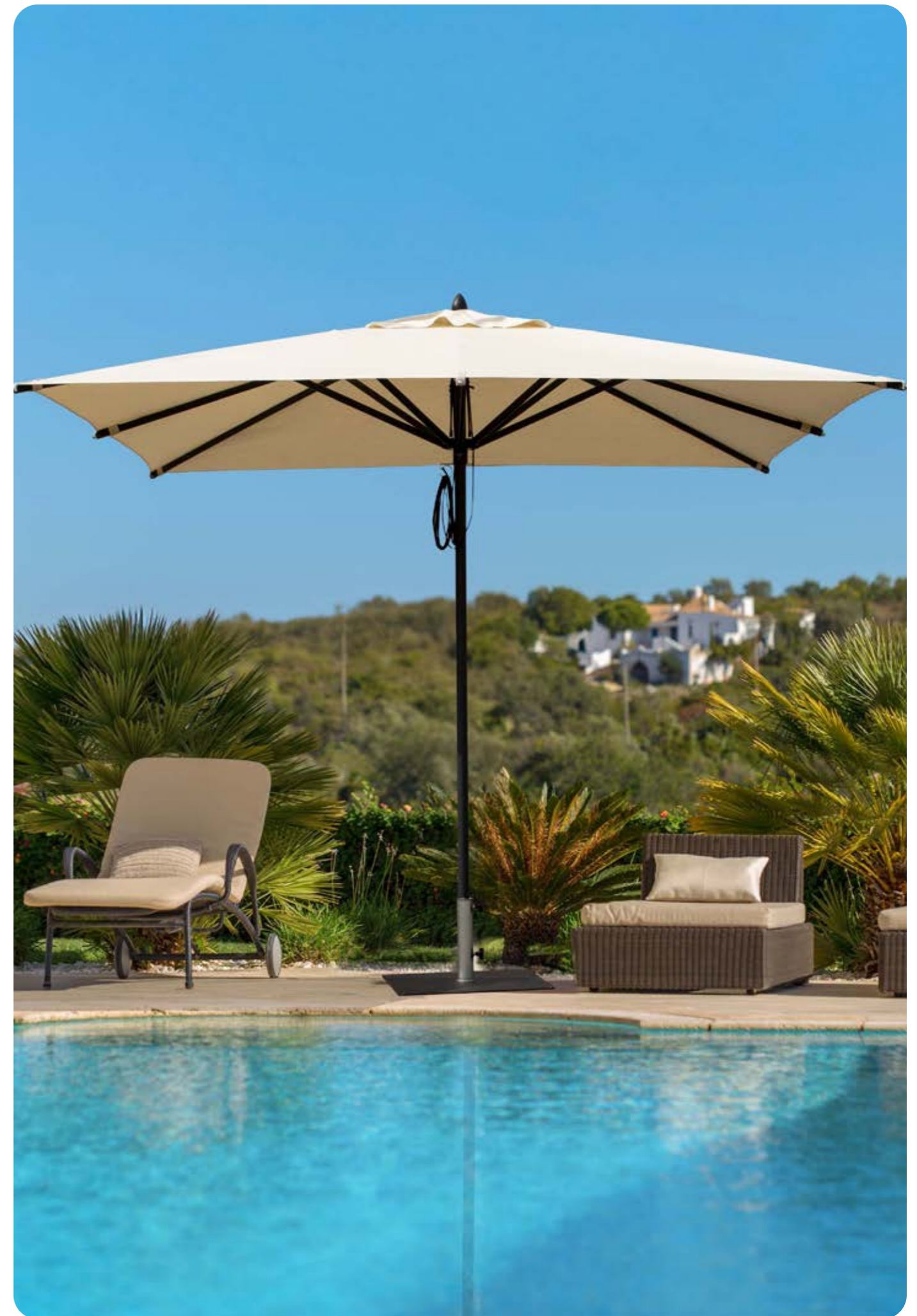



DÉCO

IT Ombrellone in legno ad uso professionale colore noce. La qualità dei materiali, l'attenta lavorazione del legno, la doppia verniciatura lo rendono un articolo durevole e senza tempo. Su richiesta telaio colore naturale e la possibilità di utilizzare tessuti acrilici riciclati.

EN Professional-grade walnut-colored wooden market umbrella. The quality of the materials, meticulous woodwork, and double coating make it a durable and timeless item. On demand we can supply natural colour frame and recycled solution dyed acrylic as well.



IT Collano legno gigante con finiture dorate.
EN Giant wooden runner with brass finish.
FR Coulant bois géant avec finition laiton.
DE Riesige Schieber mit Messing-Finish.



IT Bacchetta legno con connettore a molla.
EN Wooden rib with spring connector.
FR Baleine bois avec connecteur-ressort.
DE Holzschienen mit Federanschluss.



IT Carrucola.
EN Pulley.
FR Poulie.
DE Seilzug.



IT Aggancio tela.
EN Cover fixing.
FR Fixation toile.
DE Stoffbefestigung.



IT Palo mm 60 con carrucola.
EN Pole 60 mm with pulley.
FR Mât 60 mm avec poulie.
DE Stock 60 mm mit Seilzug.



IT Bacchette legno intercambiabili.
EN Exchangeable wooden ribs.
FR Baleines bois interchangeables.
DE Austauschbare Streben aus Holz.

FR Parasol en bois de qualité professionnelle de couleur noyer. La qualité des matériaux, le travail méticuleux du bois et la double couche de vernis en font un article durable et intemporel. Sur demande la possibilité de produire avec un bois couleur naturelle et de l'acrylique teinté en masse recyclé.

DE Professioneller Sonnenschirm aus Holz, Farbe Nuss. Die Qualität der Materialien, die sorgfältige Holzbearbeitung und die doppelte Lackierung machen ihn zu einem langlebigen und zeitlosen Artikel. Auf Anfrage naturfarbener Holz und die Möglichkeit, recycelte Acrylstoffe zu verwenden.



DÉCO

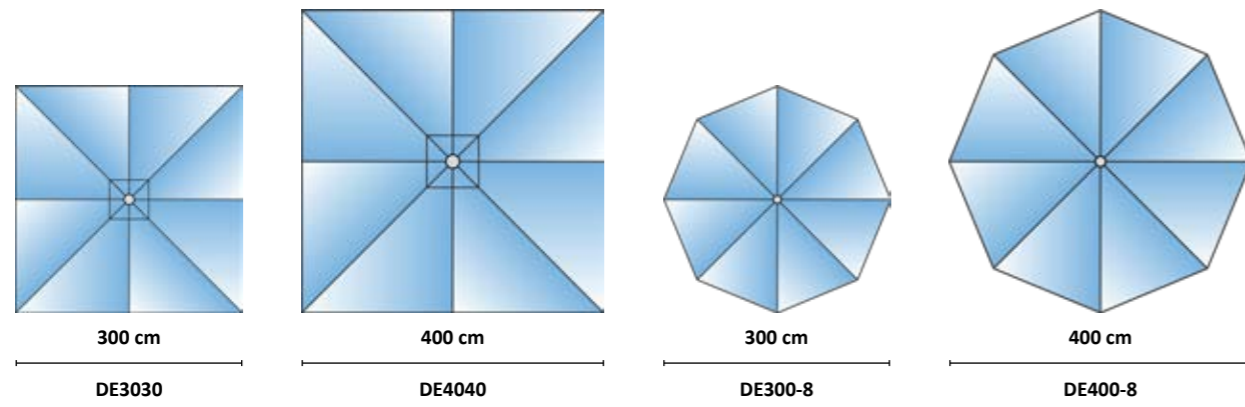

ART.	A	B
300x300/8 cm - DE3030	280 cm	72 cm
400x400/8 cm - DE4040	315 cm	37 cm
Ø 300 cm - DE300-8	280 cm	115 cm
Ø 400 cm - DE400-8	300 cm	92 cm



ART.	C	D
300x300/8 cm - DE3030	280	230
400x400/8 cm - DE4040	315	275
Ø 300 cm - DE300-8	280 cm	220 cm
Ø 400 cm - DE400-8	315 cm	240 cm

OPTIONAL



IT Art. 304X-MA. Base in cemento disegno legno, color marrone.
 EN Art. 304X-MA. Concrete base with wood design, brown colour.
 FR Art. 304X-MA. Pied en béton effet bois, couleur marron.
 DE Art. 304X-MA. Betonplattenständer mit Holzdesign, Farbe braun.

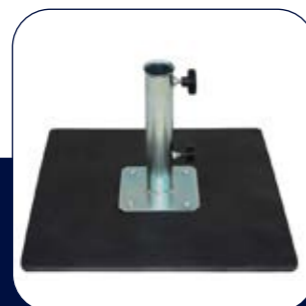

IT Art. 356X-GRA. Base metallica calpestabile, colore grafite.
 EN Art. 356X-GRA. Flat metal base, graphite colour.
 FR Art. 356X-GRA. Plaque en métal, couleur: graphite.
 DE Art. 356X-GRA. Metallständer, farbe Graphit.



IT Art. 311-65. Base in graniglia con maniglie. Ø cm 65 - kg 75
 EN Article 311-65. Grit base with handles. Ø 65 cm - 75 kg
 FR Article 311-65. Pied en grès avec poignées. Ø 65 cm - 75 kg
 DE Artikel 311-65. Betonständer mit Griffen. Ø 65 cm - 75 kg



IT Art. 356 Base piastra con ruote (optional).
 EN Art. 356 Flat base w/wheels (option).
 FR Art. 356 Plaque metal avec roulettes (option).
 DE Art. 356 Stahlständer mit Räder (option).



IT Fodera di protezione Mytex.
 EN Mytex protection cover.
 FR Housse de protection en Mytex.
 DE Mytex Schutzhülle.

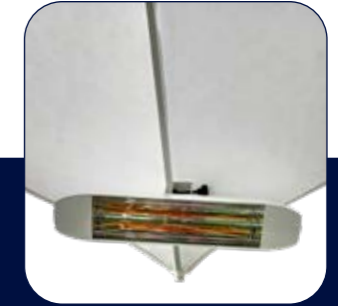

IT Riscaldatore ad infrarossi con supporto per stecca ombrellone. Disponibile in colore bianco e grafite.
 EN Infrared heater with hook for parasol rib. Available in white and graphite.
 FR Chauffage infrarouge avec crochet pour baleine parasol. Disponible en blanc et graphite.
 DE Infrarot Heizung with Hänger für Sonnenschirmschienen. Verfügbar in weiß oder Graphit.

DÉCO

IT TESSUTI - DATI TECNICI PAG. 144
EN FABRICS - TECHNICAL DATAS PAG.144

FR TISSUS - DONNÉES TECHNIQUES PAG. 144
DE STOFFE - TECHNISCHE DATEN PAG. 144

ACRILMA

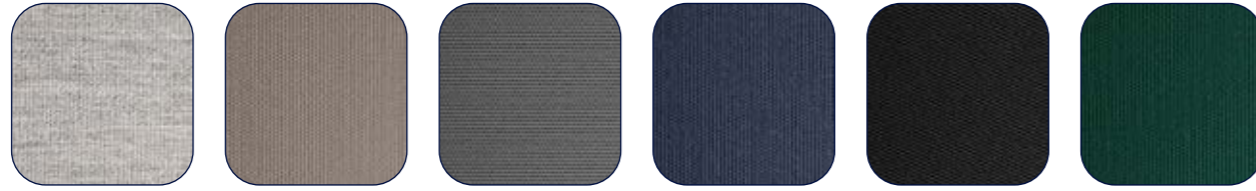

Piedra - Piedra
Piedra - Piedra

Taupe - Taupe
Taupe - Taupe

Antracite
Anthracite
Anthracite
Anthrazit

Blu - Blue
Bleu - Blau

Nero - Black
Noir - Schwarz

Verde - Green
Vert - Grün

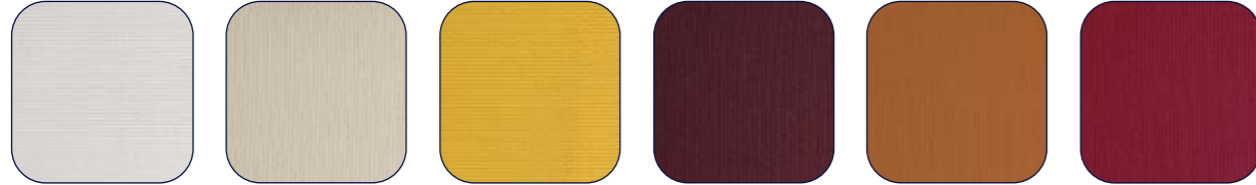

Bianco - White
Blanc - Weiß

Écru - Natural
Ecrú - Natur

Giallo - Yellow
Jaune - Gelb

Bordeaux
Burgundy
Bordeaux
Bordeaux

Terracotta
Terracotta
Terrecuite
Terracotta

Brasserie
Brasserie
Brasserie
Brasserie

SPECIAL ACRILMA

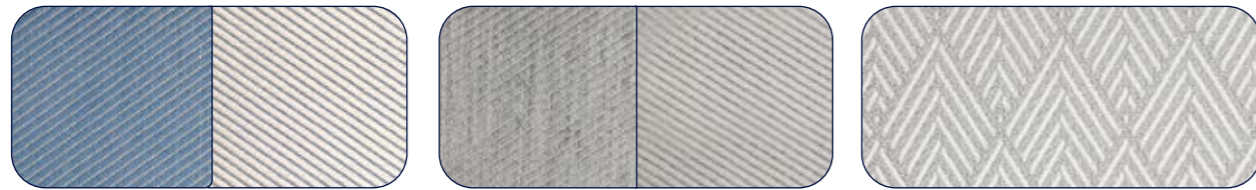

Azzurro - Azur
Azur - Azur

Grigio - Grey
Gris - Grau

Grigio - Grey
Gris - Grau

Grigio - Grey
Gris - Grau

Grigio - Grey
Gris - Grau

RAYTENT

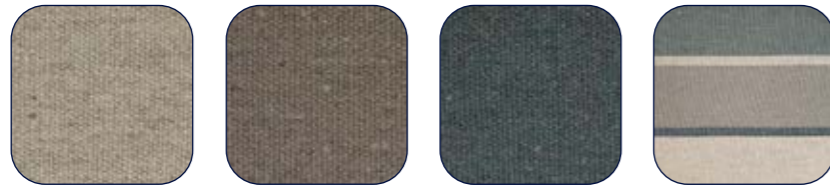

Avena
Oats
Avoine
Hafer

Pomice
Pumice
Ponce
Bimsstein

Antracite
Anthracite
Anthracite
Anthrazit

Ardesia (rigato)
Slate (stripes)
Ardoise (rayé)
Schiefer (Streifen)

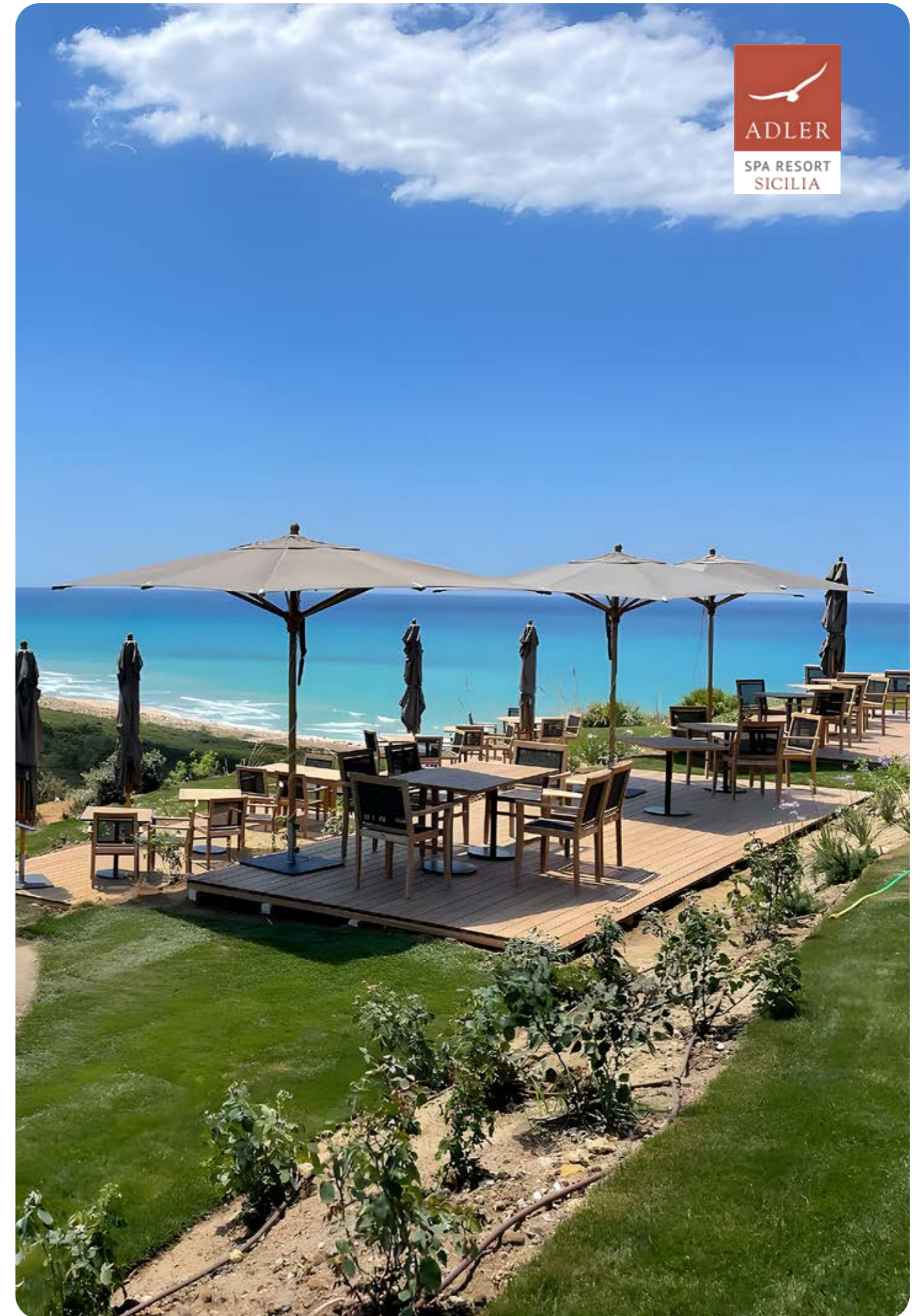

PERMAR CLASSICO



PERMAR CLASSICO

IT Ombrellone professionale con palo centrale alluminio e tessuto Acrilico tinto pasta. E' uno dei prodotti più robusti sul mercato, pensato per uso specifico spiaggia o per utilizzo intenso nelle più diverse condizioni climatiche. Il bastone, con aggancio baionetta, si adatta ai diversi sistemi professionali presenti sul mercato.

EN Commercial grade parasol, with a central aluminum pole and solution dyed acrylic fabric. It is one of the sturdiest products on the market, designed for specific beach use or for heavy-duty use in various weather conditions. The pole, with bayonet system, adapts to various professional systems available in the market.



IT Palo mm 40 in alluminio.
EN Aluminium pole 40 mm.
FR Mât aluminium 40 mm.
DE Aluminiumstock 40 mm.

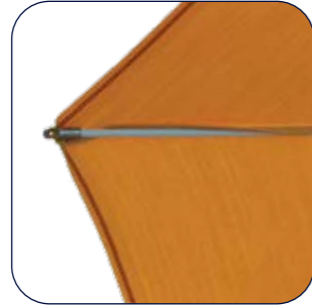

IT Puntine.
EN Tips.
FR Aiguillettes.
DE Spitzen.



IT Bacchette mm 5 zincate a caldo e verniciate+teflon.
EN 5 mm hot-dip galvanized and powder coated + Teflon ribs.
FR Baleines 5 mm galvanisée à chaud et laquées + Téflon.
DE 5 mm feuerverzinkt und lackiert Teflon Schienen.



IT Collano con Ganci appendiabiti.
EN Runner with coat hangers.
FR Coulan avec crochet.
DE Schieber mit Kleiderhaken.

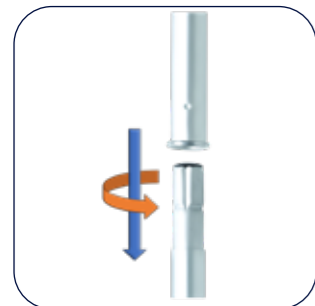

IT Prolungo in alluminio mm 40 con innesto baionetta.
EN Lower pole 40 mm with bayonet system.
FR Pique aluminium 40 mm avec système baïonnette.
DE 40 mm Unterstock mit Bajonettbefestigung.



IT Tampus.
EN Top.
FR Top.
DE Top.

FR Parasol CHR avec un mât central en aluminium et un tissu en acrylique teinté dans la masse. Il s'agit de l'un des produits les plus robustes sur le marché, conçu pour une utilisation spécifique sur la plage ou pour une utilisation intensive dans diverses conditions climatiques. Le mât, avec une fixation à baïonnette, s'adapte aux différents systèmes professionnels disponibles sur le marché.

DE Professioneller Sonnenschirm mit einem zentralen Aluminiummast und einem spinndüsengefärbtem Acryl. Es handelt sich um eines der robustesten Produkte auf dem Markt, das speziell für den Einsatz am Strand oder für den intensiven Gebrauch unter verschiedenen Wetterbedingungen entwickelt wurde. Der Mast mit Bajonettbefestigung passt sich verschiedenen professionellen Systemen auf dem Markt an.



PERMAR CLASSICO

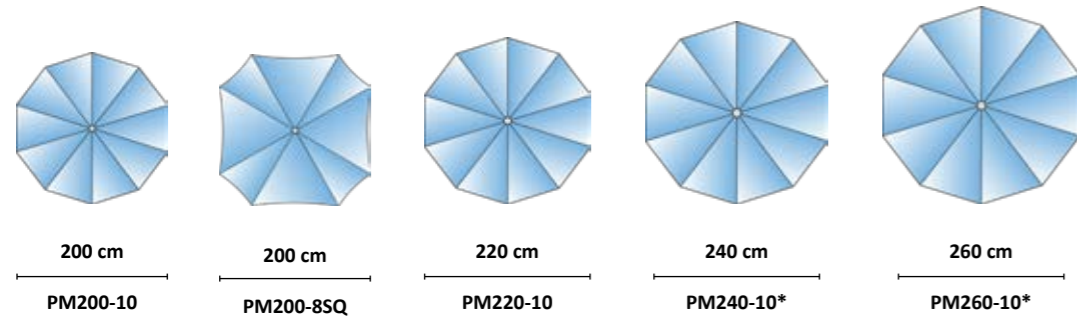

IT *Preventivo su richiesta.
 EN *Sizes on demand
 FR *Tailles sur demande
 DE *Größen auf Anfrage



ART.	A	B
PM200-10	228 cm	96 cm
PM220-10	228 cm	96 cm
PM200-8SQ	228 cm	96 cm



ART.	C	D
PM200-10	228 cm	206 cm
PM220-10	228 cm	206 cm
PM200-8SQ	228 cm	206 cm

OPTIONAL



IT Base Art. 320 +
 Tavolino Art. TAV1G.
 EN Base Art 320 + Table Art
 TAV1G.
 FR Pied Art 320 +
 Tablette Art TAV1g.
 DE Basis Art. 320 +
 Couchtisch Art. TAV1G.



IT Art 320-BIA-27. Base in
 cemento ricoperta plastica
 con tubo.
 EN Art 320-BIA-27. Plastic
 covered concrete base with
 tube.
 FR Art 320-BIA-27. Pied
 en béton recouverte de
 plastique avec tube.
 DE Art 320-BIA-27.
 Kunststoffbeschichteter
 Betonsockel mit Rohr.



IT Art 352. Base da interrare
 in alluminio.
 EN Art 320. Casting
 aluminium ground anchor.
 FR Art 320. Pied d'ancrage
 en aluminium.
 DE Art. 352. Sockel zum
 Einbetten in Aluminium.



IT Cassetta portaoggetti con
 combinazione.
 EN Box with combination
 opening.
 FR Casette avec combinaison.
 DE Kasette mit Kombination.



IT Tavolo per ombrellone.
 EN Little table for parasol.
 FR Tablette pour parasol.
 DE Sonnenschirmtisch.

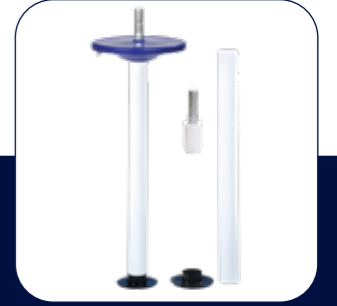

IT Set completo per ombrellone
 spiaggia con tubo PP da
 interrare, connettore e tavolino.
 EN Complete set for commercial
 beach parasol with PP lower
 pole, connector and little table.
 FR Ensemble complet pour
 parasol plagiste avec tube en
 PP, connecteur et tablette.
 DE Komplettsset mit PP
 Rohr, Verbinder und
 Sonnenschirmtisch.

PERMAR CLASSICO

IT TESSUTI - DATI TECNICI PAG. 144

FR TISSUS - DONNÉES TECHNIQUES PAG. 144

EN FABRICS - TECHNICAL DATAS PAG.144

DE STOFFE - TECHNISCHE DATEN PAG. 144

ACRILMA

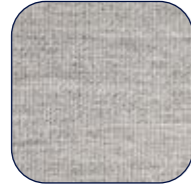

Piedra - Piedra
Piedra - Piedra



Taupe - Taupe
Taupe - Taupe



Antracite
Anthracite
Anthracite
Anthrazit



Blu - Blue
Bleu - Bleu



Nero - Black
Noir - Schwarz



Verde - Green
Vert - Grün



Bianco - White
Blanc - Weiß



Écru - Natural
Ecrú - Natur



Giallo - Yellow
Jaune - Gelb



Bordeaux
Burgundy
Bordeaux
Bordeaux

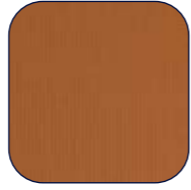

Terracotta
Terracotta
Terrecuite
Terracotta



Brasserie
Brasserie
Brasserie
Brasserie

RAYTENT



Avena
Oats
Avoine
Hafer



Pomice
Pumice
Ponce
Bimsstein



Antracite
Anthracite
Anthracite
Anthrazit

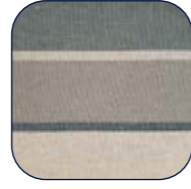

Ardesia (rigato)
Slate (stripes)
Ardoise (rayé)
Schiefer (Streifen)

DRALON



Bianco - White
Blanc - Weiß



Écru - Natural
Ecrú - Natur



PERMAR CURVO

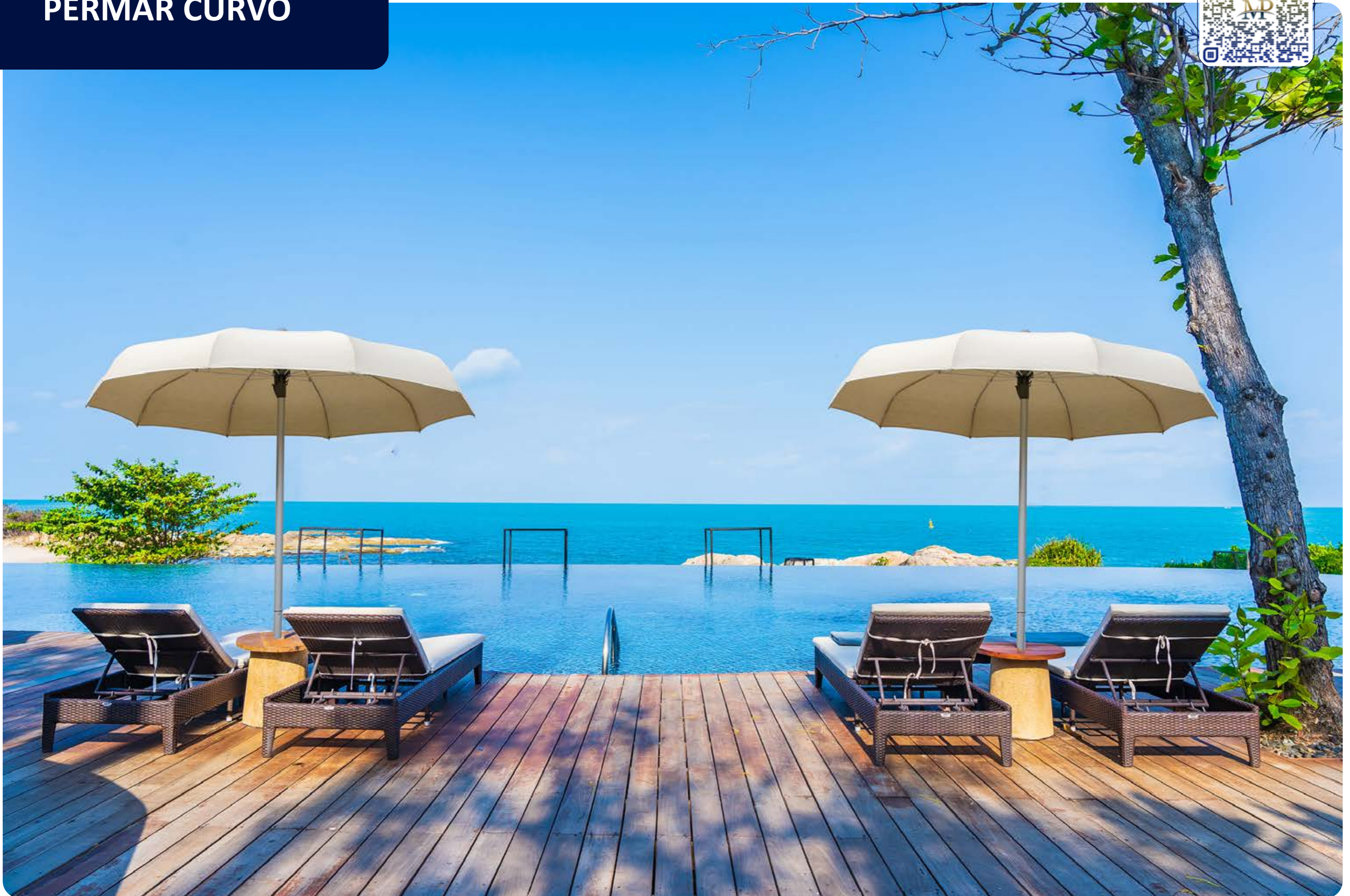

PERMAR CURVO

IT Ombrellone professionale con palo centrale alluminio e tessuto Acrilico tinto pasta. E' uno dei prodotti più robusti sul mercato, pensato per uso specifico spiaggia o per utilizzo intenso nelle più diverse condizioni climatiche. Il bastone, con aggancio baionetta, si adatta ai diversi sistemi professionali presenti sul mercato.

EN Commercial grade parasol, with a central aluminum pole and solution dyed acrylic fabric. It is one of the sturdiest products on the market, designed for specific beach use or for heavy-duty use in various weather conditions. The pole, with bayonet system, adapts to various professional systems available in the market.



IT Palo mm 40 in alluminio.
EN Aluminium pole 40 mm.
FR Mât aluminium 40 mm.
DE Aluminiumstock 40 mm.



IT Puntine.
EN Tips.
FR Aiguillettes.
DE Spitzen.



IT Bacchette mm 5 zincate a caldo e verniciate+teflon.
EN 5 mm hot-dip galvanized and powder coated + Teflon ribs.
FR Baleines 5 mm galvanisés à chaud et laquées + Téflon.
DE 5 mm feuerverzinkt und lackiert Teflon Schienen.



IT Collano con Ganci appendiabiti.
EN Runner with coat hangers.
FR Coulan avec crochet.
DE Schieber mit Kleiderhaken.

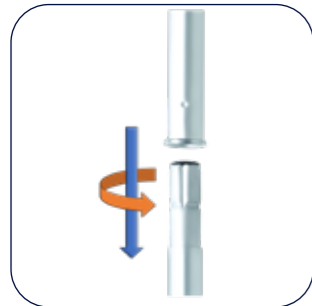

IT Prolungo in alluminio mm 40 con innesto baionetta.
EN Lower pole 40 mm with bayonet system.
FR Pique aluminium 40 mm avec système baïonnette.
DE 40 mm Unterstock mit Bajonettbefestigung.



IT Tampus.
EN Top.
FR Top.
DE Top.

FR Parasol CHR avec un mât central en aluminium et un tissu en acrylique teinté dans la masse. Il s'agit de l'un des produits les plus robustes sur le marché, conçu pour une utilisation spécifique sur la plage ou pour une utilisation intensive dans diverses conditions climatiques. Le mât, avec une fixation à baïonnette, s'adapte aux différents systèmes professionnels disponibles sur le marché.

DE Professioneller Sonnenschirm mit einem zentralen Aluminiummast und einem spinndüsengefärbtem Acryl. Es handelt sich um eines der robustesten Produkte auf dem Markt, das speziell für den Einsatz am Strand oder für den intensiven Gebrauch unter verschiedenen Wetterbedingungen entwickelt wurde. Der Mast mit Bajonettbefestigung passt sich verschiedenen professionellen Systemen auf dem Markt an.



PERMAR CURVO

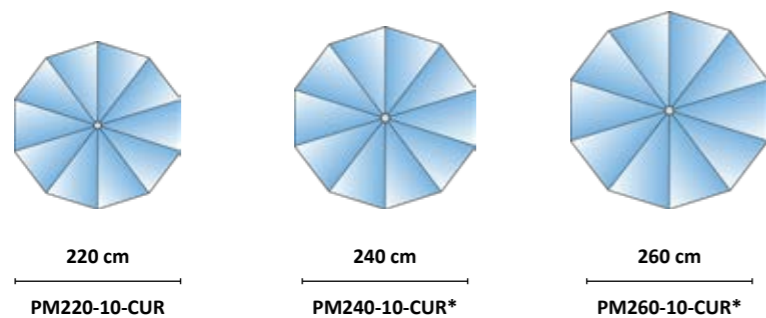

IT *Preventivo su richiesta.
EN *Sizes on demand
FR *Tailles sur demande
DE *Größen auf Anfrage

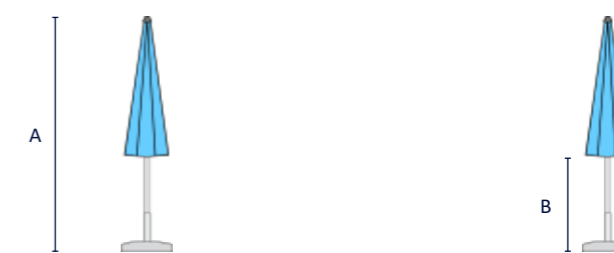

ART.	A	B
PM220-10-CURV	230 cm	124 cm

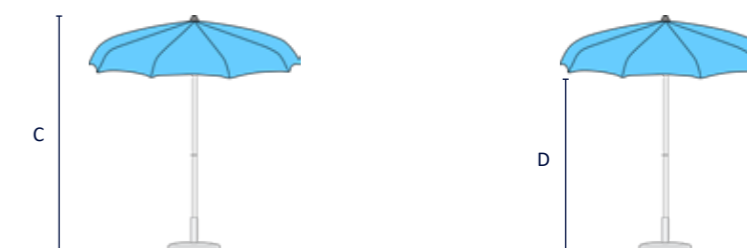

ART.	C	D
PM220-10-CURV	230 cm	190 cm

OPTIONAL



IT Base Art. 320 +
Tavolino Art. TAV1G.
EN Base Art 320 + Table Art
TAV1G.
FR Pied Art 320 +
Tablette Art TAV1g.
DE Basis Art. 320 +
Couchtisch Art. TAV1G.



IT Art 320-BIA-27. Base in
cemento ricoperta plastica
con tubo.
EN Art 320-BIA-27. Plastic
covered concrete base with
tube.
FR Art 320-BIA-27. Pied
en béton recouverte de
plastique avec tube.
DE Art 320-BIA-27.
Kunststoffbeschichteter
Betonsockel mit Rohr.



IT Art 352. Base da interrare
in alluminio.
EN Art 320. Casting
aluminium ground anchor.
FR Art 320. Pied d'ancrage
en aluminium.
DE Art. 352. Sockel zum
Einbetten in Aluminium.



IT Cassetta portaoggetti con
combinazione.
EN Box with combination
opening.
FR Casette avec combinaison.
DE Kasette mit Kombination.



IT Tavolo per ombrellone.
EN Little table for parasol.
FR Tablette pour parasol.
DE Sonnenschirmtisch.



IT Set completo per ombrellone
spiaggia con tubo PP da
interrare, connettore e tavolino.
EN Complete set for commercial
beach parasol with PP lower
pole, connector and little table.
FR Ensemble complet pour
parasol plagiste avec tube en
PP, connecteur et tablette.
DE Komplettsset mit PP
Rohr, Verbinder und
Sonnenschirmtisch.

PERMAR CURVO

IT TESSUTI - DATI TECNICI PAG. 144
EN FABRICS - TECHNICAL DATAS PAG. 144

FR TISSUS - DONNÉES TECHNIQUES PAG. 144
DE STOFFE - TECHNISCHE DATEN PAG. 144

ACRILMA

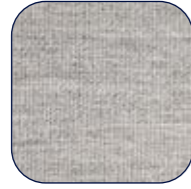

Piedra - Piedra
Piedra - Piedra



Taupe - Taupe
Taupe - Taupe



Antracite
Anthracite
Anthracite
Anthrazit



Blu - Blue
Bleu - Blau



Nero - Black
Noir - Schwarz



Verde - Green
Vert - Grün



Bianco - White
Blanc - Weiß



Écru - Natural
Ecrú - Natur



Giallo - Yellow
Jaune - Gelb



Bordeaux
Burgundy
Bordeaux
Bordeaux

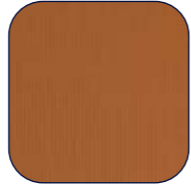

Terracotta
Terracotta
Terre cuite
Terracotta



Brasserie
Brasserie
Brasserie
Brasserie

RAYTENT



Avena
Oats
Avoine
Hafer



Pomice
Pumice
Ponce
Bimsstein



Antracite
Anthracite
Anthracite
Anthrazit

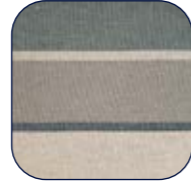

Ardesia (rigato)
Slate (stripes)
Ardoise (rayé)
Schiefer (Streifen)

DRALON

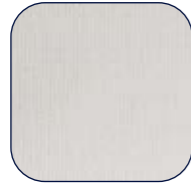

Bianco - White
Blanc - Weiß



Écru - Natural
Ecrú - Natur

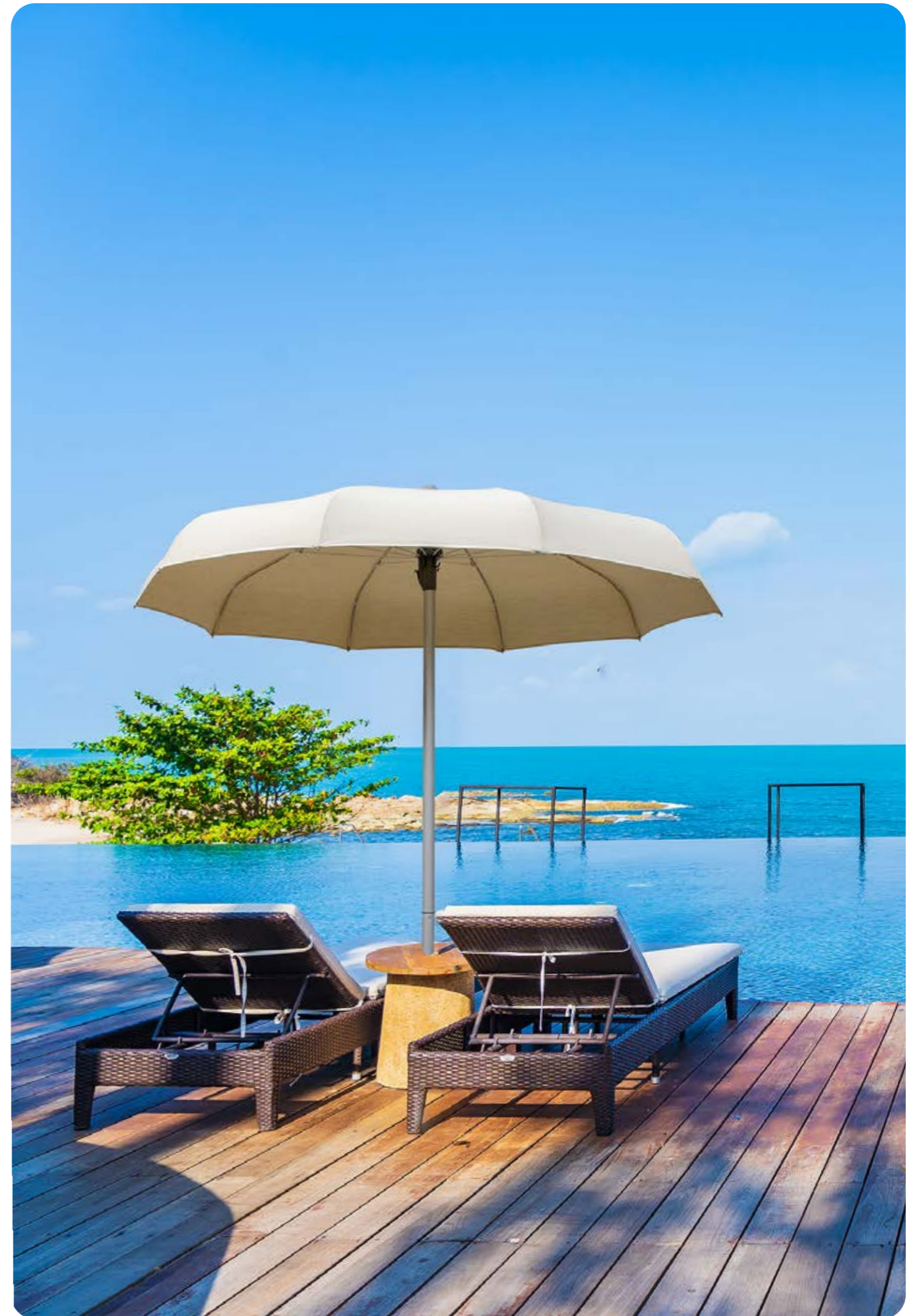

PERMAR PAGODA



PERMAR PAGODA

IT Ombrellone professionale con palo centrale alluminio e tessuto Acrilico tinto pasta. E' uno dei prodotti più robusti sul mercato, pensato per uso specifico spiaggia o per utilizzo intenso nelle più diverse condizioni climatiche. Il bastone, con aggancio baionetta, si adatta ai diversi sistemi professionali presenti sul mercato.

EN Commercial grade parasol, with a central aluminum pole and solution dyed acrylic fabric. It is one of the sturdiest products on the market, designed for specific beach use or for heavy-duty use in various weather conditions. The pole, with bayonet system, adapts to various professional systems available in the market.

FR Parasol CHR avec un mât central en aluminium et un tissu en acrylique teinté dans la masse. Il s'agit de l'un des produits les plus robustes sur le marché, conçu pour une utilisation spécifique sur la plage ou pour une utilisation intensive dans diverses conditions climatiques. Le mât, avec une fixation à baïonnette, s'adapte aux différents systèmes professionnels disponibles sur le marché.

DE Professioneller Sonnenschirm mit einem zentralen Aluminiummast und einem spinndüsengefärbtem Acryl. Es handelt sich um eines der robustesten Produkte auf dem Markt, das speziell für den Einsatz am Strand oder für den intensiven Gebrauch unter verschiedenen Wetterbedingungen entwickelt wurde. Der Mast mit Bajonettbefestigung passt sich verschiedenen professionellen Systemen auf dem Markt an.



IT Palo mm 40 in alluminio.
EN Aluminium pole 40 mm.
FR Mât aluminium 40 mm.
DE Aluminiumstock 40 mm.



IT Puntine.
EN Tips.
FR Aiguillettes.
DE Spitzen.



IT Bacchette mm 5 zincate a caldo e verniciate+teflon.
EN 5 mm hot-dip galvanized and powder coated + Teflon ribs.
FR Baleines 5 mm galvanisés à chaud et laquées + Téflon.
DE 5 mm feuerverzinkt und lackiert Teflon Schienen.



IT Collano con Ganci appendiabiti.
EN Runner with coat hangers.
FR Coulan avec crochet.
DE Schieber mit Kleiderhaken.

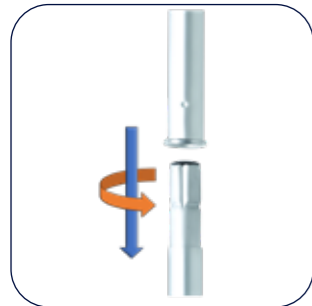

IT Prolungo in alluminio mm 40 con innesto baionetta.
EN Lower pole 40 mm with bayonet system.
FR Pique aluminium 40 mm avec système baïonnette.
DE 40 mm Unterstock mit Bajonettbefestigung.



IT Tampus.
EN Top.
FR Top.
DE Top.



PERMAR PAGODA



220 cm
PM220-10-PAG

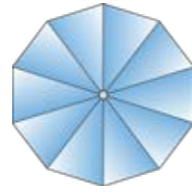

240 cm
PM240-10-PAG*

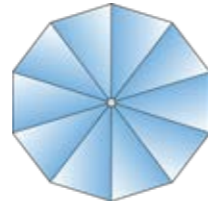

260 cm
PM260-10-PAG*

IT *Preventivo su richiesta.
EN *Sizes on demand
FR *Tailles sur demande
DE *Größen auf Anfrage

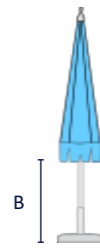
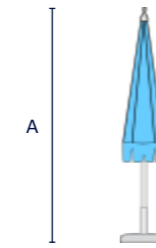

ART.	A	B
PM220-10-PAG	254 cm	124 cm

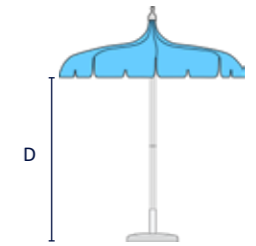
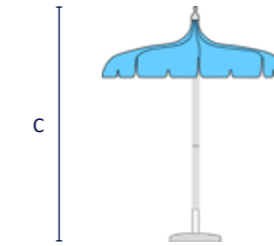

ART.	C	D
PM220-10-PAG	254 cm	195 cm

OPTIONAL



IT Base Art. 320 +
Tavolino Art. TAV1G.
EN Base Art 320 + Table Art
TAV1G.
FR Pied Art 320 +
Tablette Art TAV1g.
DE Basis Art. 320 +
Couchtisch Art. TAV1G.



IT Art 320-BIA-27. Base in
cemento ricoperta plastica
con tubo.
EN Art 320-BIA-27. Plastic
covered concrete base with
tube.
FR Art 320-BIA-27. Pied
en béton recouverte de
plastique avec tube.
DE Art 320-BIA-27.
Kunststoffbeschichteter
Betonsockel mit Rohr.



IT Art 352. Base da interrare
in alluminio.
EN Art 320. Casting
aluminium ground anchor.
FR Art 320. Pied d'ancrage
en aluminium.
DE Art. 352. Sockel zum
Einbetten in Aluminium.



IT Cassetta portaoggetti con
combinazione.
EN Box with combination
opening.
FR Casette avec combinaison.
DE Kasette mit Kombination.



IT Tavolo per ombrellone.
EN Little table for parasol.
FR Tablette pour parasol.
DE Sonnenschirmtisch.

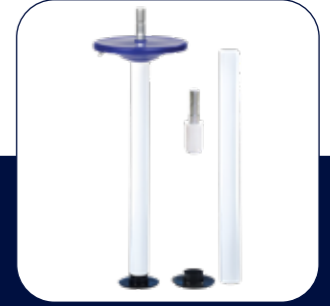

IT Set completo per ombrellone
spiaggia con tubo PP da
interrare, connettore e tavolino.
EN Complete set for commercial
beach parasol with PP lower
pole, connector and little table.
FR Ensemble complet pour
parasol plagiste avec tube en
PP, connecteur et tablette.
DE Komplettsset mit PP
Rohr, Verbinder und
Sonnenschirmtisch.

PERMAR PAGODA

IT TESSUTI - DATI TECNICI PAG. 144
 EN FABRICS - TECHNICAL DATAS PAG.144

FR TISSUS - DONNÉES TECHNIQUES PAG. 144
 DE STOFFE - TECHNISCHE DATEN PAG. 144

ACRILMA

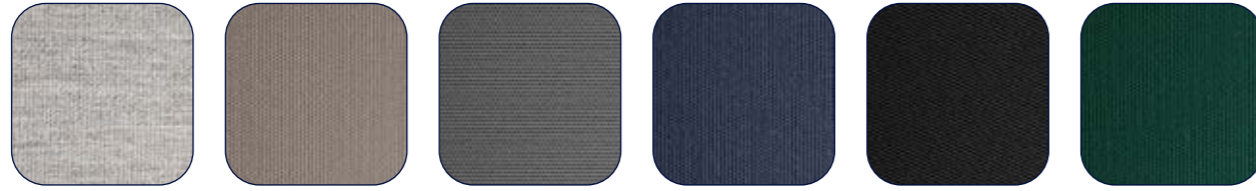

Piedra - Piedra
Piedra - Piedra

Taupe - Taupe
Taupe - Taupe

Antracite
Anthracite
Anthracite
Anthrazit

Blu - Blue
Bleu - Blau

Nero - Black
Noir - Schwarz

Verde - Green
Vert - Grün

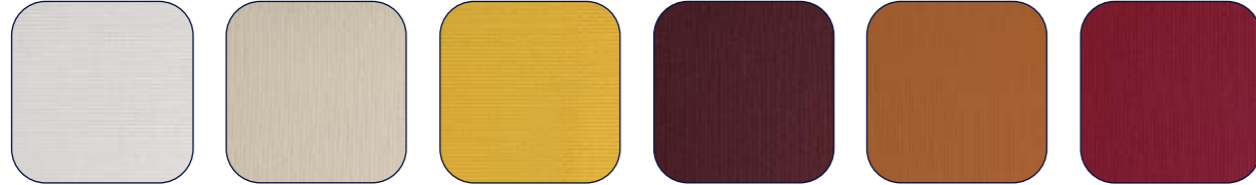

Bianco - White
Blanc - Weiß

Écru - Natural
Ecrú - Natur

Giallo - Yellow
Jaune - Gelb

Bordeaux
Burgundy
Bordeaux
Bordeaux

Terracotta
Terracotta
Terrecuite
Terracotta

Brasserie
Brasserie
Brasserie
Brasserie

RAYTENT

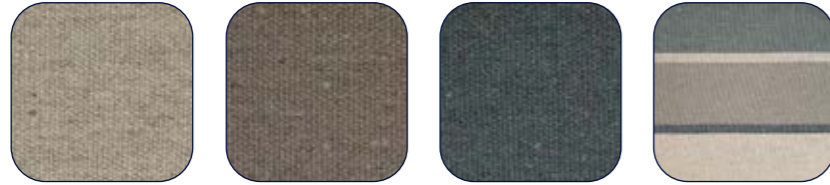

Avena
Oats
Avoine
Hafer

Pomice
Pumice
Ponce
Bimsstein

Antracite
Anthracite
Anthracite
Anthrazit

Ardesia (rigato)
Slate (stripes)
Ardoise (rayé)
Schiefer (Streifen)

DRALON

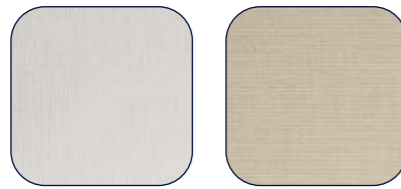

Bianco - White
Blanc - Weiß

Écru - Natural
Ecrú - Natur



ALFA



ALFA

IT Ombrellone per uso professionale con palo centrale alluminio e bacchette in fibra di vetro. La combinazione di palo alluminio, accessori resina, bacchette in fibra da 8 mm e tessuto acrilico tinto pasta, unito ad una lavorazione impeccabile, offre un prodotto d'eccellenza.

EN Commercial grade parasol with a central aluminum pole and fiberglass ribs. The combination of the aluminum pole, resin accessories, 8mm fiberglass ribs, and solution dyed acrylic fabric, together with experienced craftsmanship, lead to an excellent product.



IT Struttura alluminio e fibra di vetro.
EN Aluminium and fiberglass frame.
FR Structure en alu et fibre de verre.
DE Aluminium + Glasfaser Gestell.



IT Collano con pulsante di apertura.
EN Runner with pushbutton.
FR Coulan avec bouton.
DE Schieber mit Druck.



IT Tampus a palla.
EN Ball top.
FR Top à balle.
DE Kugeltop.



IT Bacchette in fibra di vetro mm 8.
EN 8 mm fiberglass ribs.
FR Baleines en fibre de verre de 8 mm.
DE 8 mm Glasfaserschienen.

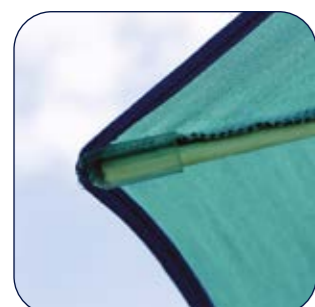

IT Puntina a tasca.
EN Pocket Tip.
FR Embout.
DE Taschespitz.



IT Pali in alluminio rigato mm 35/40.
EN Aluminum striped poles 35/40 mm.
FR Mât en aluminium strié 35/40 mm.
DE Gestreift Aluminiumstock 35/40 mm.

FR Parasol CHR avec un mât central en aluminium et des baleines en fibre de verre. La combinaison du mât en aluminium, des accessoires en résine, des baleines en fibre de verre de 8 mm et du tissu en acrylique teinté dans la masse, associée à une finition impeccable, offre un produit d'excellence.

DE Professioneller Sonnenschirm mit zentralem Aluminiumstock und Fiberglasstreben. Die Kombination aus Aluminiumstock, Harz-Zubehöre, 8mm Fiberglasstreben und spinndüsengefärbtes Acryl, gepaart mit makelloser Verarbeitung, ergibt ein ausgezeichnetes Produkt.



ALFA

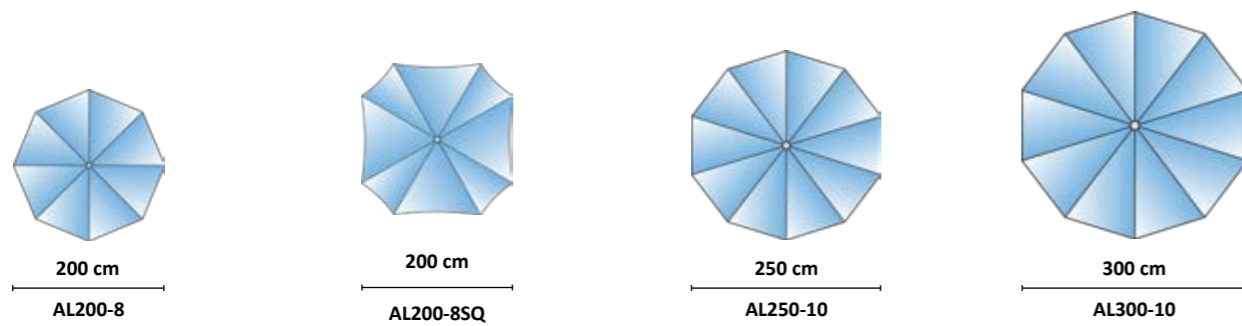

ART.	A	B
AL200-8	210/225 cm	105/120 cm
AL200-8SQ	210/225 cm	105/120 cm
AL250-10	230/250 cm	115/125 cm
AL300-10	230/250 cm	115/135 cm



ART.	C	D
AL200-8	210/225 cm	115/195 cm
AL200-8SQ	210/225 cm	115/195 cm
AL250-10	230/250 cm	150/215 cm
AL300-10	230/250 cm	150/215 cm

OPTIONAL



IT Art 301. Base in graniglia.
EN Art 301. Grit base.
FR Art 301. Pied en grès.
DE Art. 301. Betonständer.



IT Art 320-BIA-27. Base in cemento ricoperta plastica con tubo.
EN Art 320-BIA-27. Plastic covered concrete base with tube.
FR Art 320-BIA-27. Pied en béton recouverte en plastique avec tube.
DE Art 320-BIA-27. Kunststoffbeschichteter Betonsockel mit Rohr.



IT Art 322 Base cemento ricoperta kg 27, tubo PP, tavolino.
EN Art 322 kg 27 concrete base covered with plastic, PP tube, little table.
FR Art 322 Pied béton couvert avec plastique, tube PP, tablette.
DE Art 322 Betonständer mit Kunststoff überzogen, PP Stock, Schirmtisch.

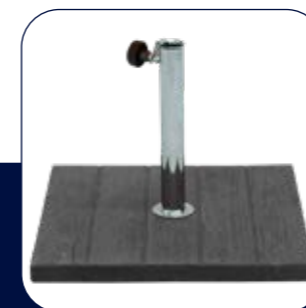

IT Art. 304. Base in cemento disegno legno, colore grigio.
EN Art. 304. Concrete base with wood design, grey colour.
FR Article 304. Pied en béton avec motif bois, couleur gris.
DE Art. 304. Betonplatteständer mit Holzdesign, Farbe Grau.



IT Art 352. Base da interrare in alluminio.
EN Art 352. Casting aluminium ground anchor.
FR Art 320. Pied d'ancrage en aluminium.
DE Art. 352. Sockel aus Aluminium.



IT Fodera di protezione Mytex.
EN Mytex protection cover.
FR Housse de protection en Mytex.
DE Mytex Schutzhülle.

ALFA

IT TESSUTI - DATI TECNICI PAG. 144
EN FABRICS - TECHNICAL DATAS PAG.144

FR TISSUS - DONNÉES TECHNIQUES PAG. 144
DE STOFFE - TECHNISCHE DATEN PAG. 144

ACRILMA

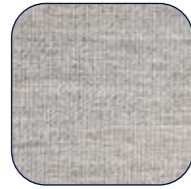

Piedra - Piedra
Piedra - Piedra



Taupe - Taupe
Taupe - Taupe

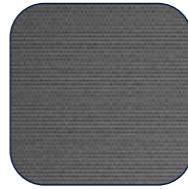

Antracite
Anthracite
Anthracite
Anthrazit



Blu - Blue
Bleu - Blau



Nero - Black
Noir - Schwarz



Verde - Green
Vert - Grün



Bianco - White
Blanc - Weiß



Écru - Natural
Ecrú - Natur

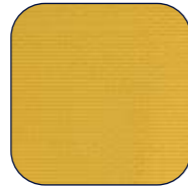

Giallo - Yellow
Jaune - Gelb



Bordeaux
Burgundy
Bordeaux
Bordeaux

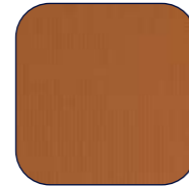

Terracotta
Terracotta
Terre cuite
Terracotta

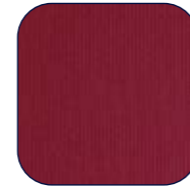

Brasserie
Brasserie
Brasserie
Brasserie

RAYTENT



Avena
Oats
Avoine
Hafer



Pomice
Pumice
Ponce
Bimsstein



Antracite
Anthracite
Anthracite
Anthrazit



Ardesia (rigato)
Slate (stripes)
Ardoise (rayé)
Schiefer (Streifen)

DRALON

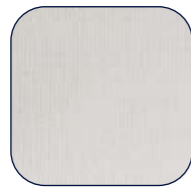

Bianco - White
Blanc - Weiß



Écru - Natural
Ecrú - Natur



BETA



BETA 250x250/8

IT Ombrellone per uso professionale con palo centrale e bacchette alluminio. La combinazione di palo alluminio, accessori resina rinforzata, bacchette in alluminio di elevato spessore, tessuto acrilico tinto pasta, unito ad una lavorazione impeccabile, offre un prodotto d'eccellenza.

EN Commercial grade parasol with a central aluminum pole and ribs. The combination of the aluminum pole, reinforced resin accessories, sturdy ribs and solution dyed acrylic fabric, together with experienced craftsmanship, lead to an excellent product.

FR Parasol CHR avec un mât central et baleines en aluminium. La combinaison du mât en aluminium, des accessoires en résine renforcée, des baleines solides et du tissu en acrylique teinté dans la masse, associée à une finition impeccable, offre un produit d'excellence.

DE Professioneller Sonnenschirm mit zentralem Stock und Schienen aus Aluminium. Die Kombination aus Aluminiumstock, verstärkter Harz-Zubehöre, dick Alustreben und spinndüsengefärbtes Acryl, gepaart mit makelloser Verarbeitung, ergibt ein ausgezeichnetes Produkt.



IT Collano con pulsante di apertura.
EN Runner with pushbutton.
FR Coulan avec bouton.
DE Schieber mit Druck.



IT Struttura alluminio 250x250.
EN Aluminium frame 250x250.
FR Structure en alu 250x250.
DE Aluminium Gestell 250x250.



IT Bacchette in alluminio spessore 1,4 mm.
EN Aluminium ribs 1,4 mm thick.
FR Baleines en aluminium épaisseur de 1,4 mm.
DE 1,4 mm dick Aluminiumschienen.



IT Aggancio tela.
EN Cover fixing.
FR Fixation toile.
DE Stoffbefestigung.

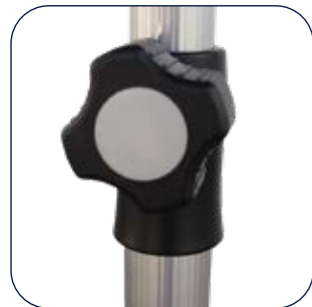

IT Pali in alluminio rigato mm 35/40.
EN Aluminium striped poles 35/40 mm.
FR Mât en aluminium strié 35/40 mm.
DE Gestreift Aluminiumstock 35/40 mm.



IT Tampus a palla.
EN Ball top.
FR Top à balle.
DE Kugeltop.



BETA 210x210/4

IT Ombrellone per uso professionale con palo centrale e bacchette alluminio. La combinazione di palo alluminio, accessori resina rinforzata, bacchette in alluminio di elevato spessore, tessuto acrilico tinto pasta, unito ad una lavorazione impeccabile, offre un prodotto d'eccellenza.

EN Commercial grade parasol with a central aluminum pole and ribs. The combination of the aluminum pole, reinforced resin accessories, sturdy ribs and solution dyed acrylic fabric, together with experienced craftsmanship, lead to an excellent product.

FR Parasol CHR avec un mât central et baleines en aluminium. La combinaison du mât en aluminium, des accessoires en résine renforcée, des baleines solides et du tissu en acrylique teinté dans la masse, associée à une finition impeccable, offre un produit d'excellence.

DE Professioneller Sonnenschirm mit zentralem Stock und Schienen aus Aluminium. Die Kombination aus Aluminiumstock, verstärkter Harz-Zubehöre, dick Alustreben und spinndüsengefärbtes Acryl, gepaart mit makelloser Verarbeitung, ergibt ein ausgezeichnetes Produkt.



IT Collano con pulsante di apertura.
EN Runner with pushbutton.
FR Coulan avec bouton.
DE Schieber mit Druck.



IT Struttura alluminio 210x210.
EN Aluminium frame 210x210.
FR Structure en alu 210x210.
DE Aluminium Gestell 210x210.



IT Bacchette in alluminio spessore 1,4 mm.
EN Aluminium ribs 1,4 mm thick.
FR Baleines en aluminium épaisseur de 1,4 mm.
DE 1,4 mm dick Aluminiumschienen.



IT Aggancio tela.
EN Cover fixing.
FR Fixation toile.
DE Stoffbefestigung.



IT Pali in alluminio rigato mm 35/40.
EN Aluminium striped poles 35/40 mm.
FR Mât en aluminium strié 35/40 mm.
DE Gestreift Aluminiumstock 35/40 mm.

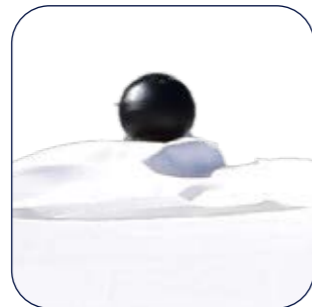

IT Tampus a palla.
EN Ball top.
FR Top à balle.
DE Kugeltop.



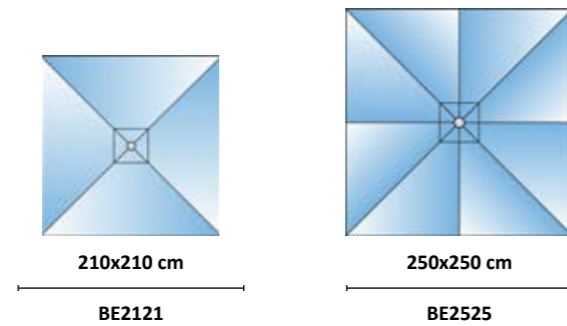

ART.	A	B
BE2525	230/280 cm	58/68 cm
BE2121	230/270 cm	112 cm

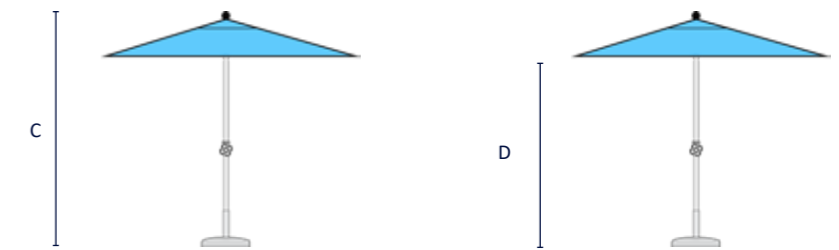

ART.	C	D
BE2525	230/280 cm	200/250 cm
BE2121	230/270 cm	220/240 cm

OPTIONAL



IT Art.301. Base graniglia.
EN Art.301. Grit base.
FR Art.301. Pied en grès.
DE Art.301. Waschbetonständer.



IT Art 320-BIA-27. Base in cemento ricoperta plastica con tubo.
EN Art 320-BIA-27. Plastic covered concrete base with tube.
FR Art 320-BIA-27. Pied en béton recouverte de plastique avec tube.
DE Art 320-BIA-27. Kunststoffbeschichteter Betonsockel mit Rohr.



IT Art 322 Base cemento ricoperta kg 27, tubo PP, tavolino.
EN Art 322 kg 27 concrete base covered with plastic, PP tube, little table.
FR Art 322 Pied béton couvert avec plastique, tube PP, tablette.
DE Art 322 Betonständer mit Kunststoff überzogen, PP Stock, Schirmtisch.

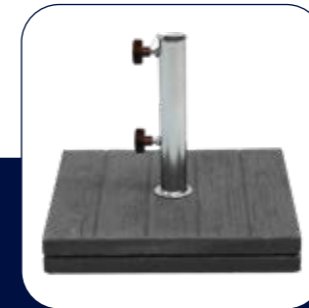

IT Art. 304X. Base in cemento disegno legno, colore grigio.
EN Art. 304X. Concrete base with wood design, grey colour.
FR Article 304X. Pied en béton avec motif bois, couleur gris.
DE Art. 304X. Betonsockel mit Holzdesign, grau Farbe.



IT Art 352. Base da interrare in alluminio.
EN Art 352. Casting aluminium ground anchor.
FR Art 320. Pied d'ancrage en aluminium.
DE Art. 352. Sockel aus Aluminium.



IT Fodera di protezione Mytex.
EN Mytex protection cover.
FR Housse de protection en Mytex.
DE Mytex Schutzhülle.

BETA

IT TESSUTI - DATI TECNICI PAG. 144
EN FABRICS - TECHNICAL DATAS PAG.144

FR TISSUS - DONNÉES TECHNIQUES PAG. 144
DE STOFFE - TECHNISCHE DATEN PAG. 144

ACRILMA

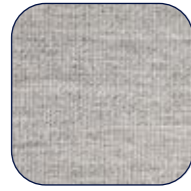

Piedra - Piedra
Piedra - Piedra



Taupe - Taupe
Taupe - Taupe



Antracite
Anthracite
Anthracite
Anthrazit



Blu - Blue
Bleu - Blau



Nero - Black
Noir - Schwarz



Verde - Green
Vert - Grün

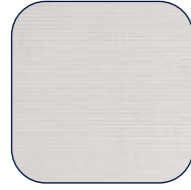

Bianco - White
Blanc - Weiß



Écru - Natural
Ecrú - Natur



Giallo - Yellow
Jaune - Gelb



Bordeaux
Burgundy
Bordeaux
Bordeaux

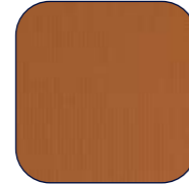

Terracotta
Terracotta
Terrecuite
Terracotta



Brasserie
Brasserie
Brasserie
Brasserie

RAYTENT



Avena
Oats
Avoine
Hafer



Pomice
Pumice
Ponce
Bimsstein



Antracite
Anthracite
Anthracite
Anthrazit

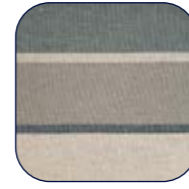

Ardesia (rigato)
Slate (stripes)
Ardoise (rayé)
Schiefer (Streifen)

DRALON

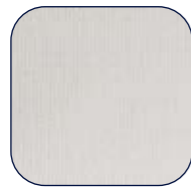

Bianco - White
Blanc - Weiß



Écru - Natural
Ecrú - Natur

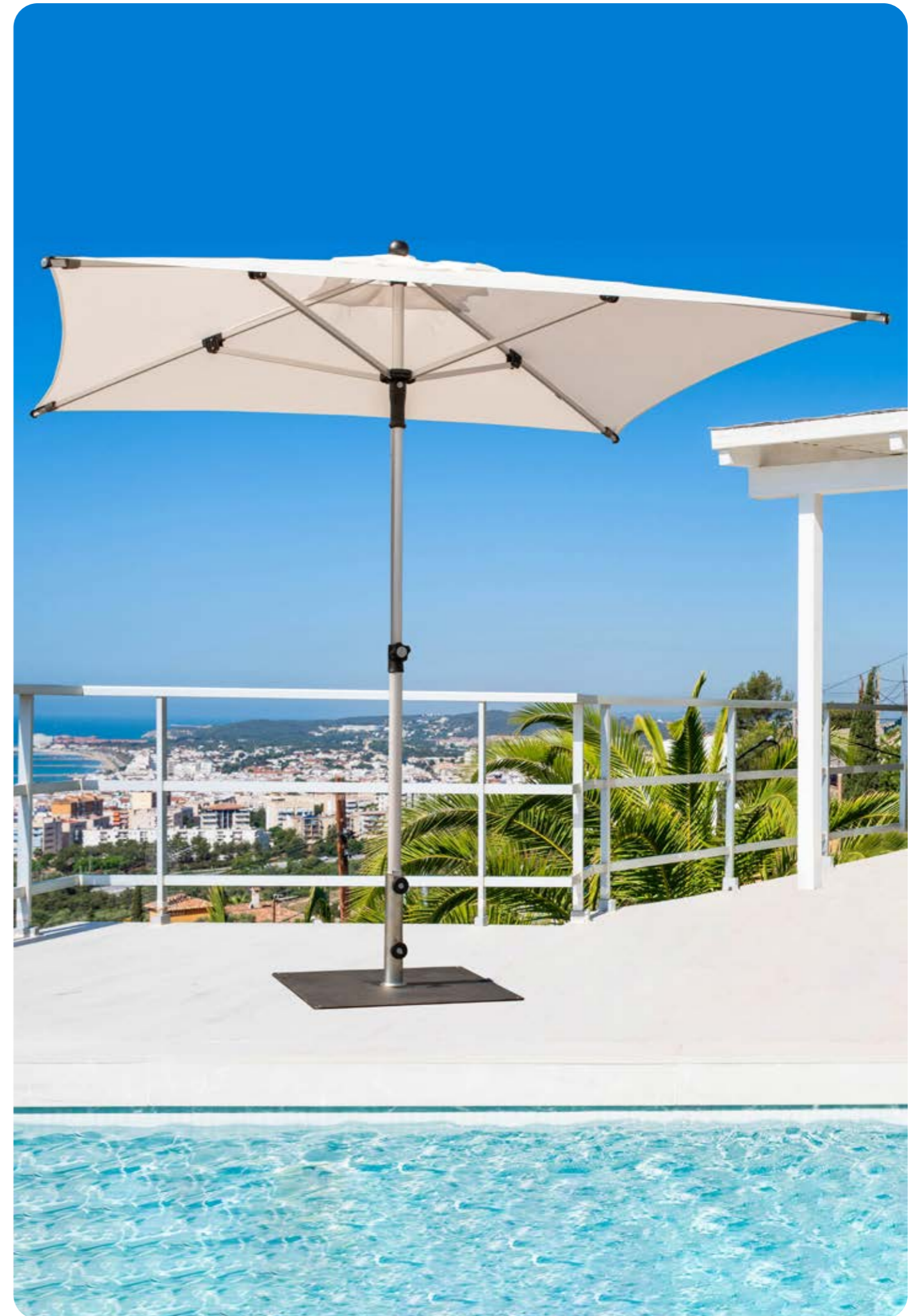

ZANZIBAR



ZANZIBAR

IT Ombrellone ricoperto rafia ad uso professionale con struttura palo alluminio.

FR Parasol avec raphia, qualité CHR et structure mât aluminium.

EN Commercial grade parasol covered with straw and aluminium pole.

DE Professionaler Bastschirm mit Alustock.



IT Struttura palo alluminio con bacchette acciaio.
EN Aluminium pole with steel ribs.
FR Structure en alu avec baleines acier.
DE Aluminium Gestell mit Stahlstreben.



IT Collano con pulsante di apertura.
EN Runner with pushbutton.
FR Coulan avec bouton.
DE Schieber mit Druck.



IT Bacchette in acciaio zincato e verniciato 4,5mm.
EN Galvanised and coated ribs 4,5 mm.
FR Baleines acier zingué et vernis 4,5 mm.
DE 4,5 mm galvanisierte und lackierte Stahlstreben.



IT Puntine.
EN Tips.
FR Aiguillettes.
DE Spitzen.



IT Molla di sostegno in acciaio inox mm 35/40.
EN Stainless steel supporting spring 35/40 mm.
FR Ressort d'ouverture en acier inox 35/40 mm.
DE Edelstahl Feder 35/40 mm.



IT Pali in alluminio rigato mm 35/40.
EN Aluminium striped poles 35/40 mm.
FR Mât en aluminium strié 35/40 mm.
DE Gestreift Aluminiumstock 35/40 mm.



ZANZIBAR

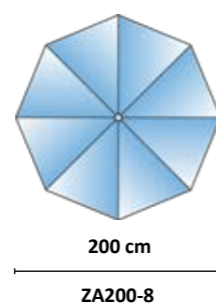

ART.	A	B
ZA200-8	215 cm	96 cm



ART.	C	D
ZA200-8	215 cm	190 cm

IT TESSUTI - DATI TECNICI PAG. 144
EN FABRICS - TECHNICAL DATAS PAG.144

FR TISSUS - DONNÉES TECHNIQUES PAG. 144
DE STOFFE - TECHNISCHE DATEN PAG. 144

POLYMA

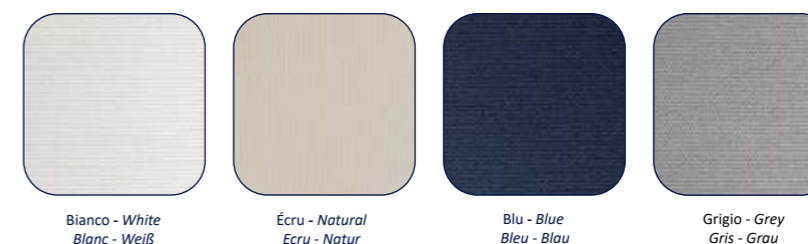

OPTIONAL



IT Art. 304B-38. Base in cemento disegno legno, colore bianco.
EN Article 304-38. Concrete pied with wood design, white colour.
FR Article 304-38. Pied en béton avec motif bois, couleur blanc.
DE Artikel 304-38. Betonsockel mit Holzdesign, Weiß Farbe.



IT Art 320-BIA-27. Base in cemento ricoperta plastica con tubo.
EN Art 320-BIA-27. Plastic covered concrete base with tube.
FR Art 320-BIA-27. Pied en béton recouverte de plastique avec tube.
DE Art 320-BIA-27. Kunststoffbeschichteter Betonsockel mit Rohr.



IT Art 352. Base da interrare in alluminio.
EN Art 352. Casting aluminium ground anchor.
FR Art 320. Pied d'ancrage en aluminium.
DE Art. 352. Sockel aus Aluminium.

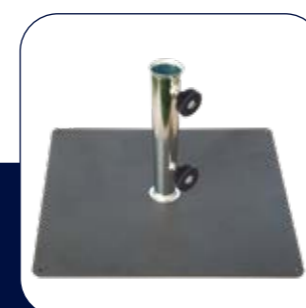

IT Art. 358-GRA. Base metallica calpestabile, colore grafite
EN Art. 358-GRA. Flat metal base, graphite colour.
FR Art. 358-GRA. Plaque en métal, couleur: graphite.
DE Art. 358-GRA. Metallständer Farbe Graphit.



IT Art 322 Base cemento ricoperta kg 27, tubo PP, tavolino.
EN Art 322 kg 27 concrete base covered with plastic, PP tube, little table.
FR Art 322 Pied béton couvert avec plastique, tube PP, tablette.
DE Art 322 Betonständer mit Kunststoff überzogen, PP Stock, Schirmtisch.



IT Fodera di protezione Mytex.
EN Mytex protection cover.
FR Housse de protection en Mytex.
DE Mytex Schutzhülle.

SUPERINOX



SUPERINOX

IT Ombrellone professionale con palo in acciaio inox e tessuto Acrilico tinto pasta. Il palo inox da 23 mm è molto forte e quindi questo ombrellone è pensato per essere utilizzato in spiaggia o per uso intenso. Il prolungo, venduto separatamente, può essere in acciaio inox conificato oppure angolare in acciaio zincato.

EN Commercial grade parasol with stainless steel pole and solution dyed Acrylic fabric. The 23 mm s/s pole is very strong and so the parasol is suitable to professional use at the beach or other heavy duty use. The lower pole, separately sold, can be in stainless steel as well or a corner shape galvanized steel.

FR Parasol CHR avec un mât en acier inox et un tissu en acrylique teinté dans la masse. Le mât en acier inox de 23 mm est très fort et donc ce parasol est adapté à l'utilisation plagiste ou à hautes performances. Le pique, vendu séparément, peut être en acier inox conifié ou cornière en acier zingué.

DE Professioneller Sonnenschirm mit einem 23 mm Stock aus Edehstahl und einem spinndüsengefärbtem Acryl. Der 23mm Stock ist sehr stark, so kann dieser Sonnenschirm besonders am Strand oder für den intensiven Gebrauch entwickelt wurde. Der Unterstock, separat erhältlich, kann aus Edelstahl mit anlaufende Spitze sein, oder Eckform aus verzinkter Stahl.



IT Palo mm 23 in acciaio inox.
EN Stainless steel pole 23 mm.
FR Mât 23 mm en acier inox.
DE Stock aus Edelstahl 23 mm.



IT Tampus.
EN Top.
FR Top.
DE Top.



IT Collano resina rinforzata.
EN Reinforced resin runner.
FR Coulan resin renforcé.
DE Schieber mit verstärktem Harz.



IT Vite di bloccaggio per prolungo.
EN Blocking screw for lower pole.
FR Vis de serrage pour pique.
DE Schraub für Unterstock.



IT Bacchette mm 4,50 zincate e verniciate.
EN Galvanised and coated ribs 4,50 mm.
FR Baleines zinguées et vernies 4,50 mm.
DE Verzinkte und lackierte Schienen 4,50 mm.



IT Prolungo acciaio inox 28 mm conificato.
EN Stainless steel pointed 28 mm lower pole.
FR Pique en acier inox conifié 28 mm.
DE mm 28 anlaufende Spitze Unterstock aus Edelstahl



SUPERINOX

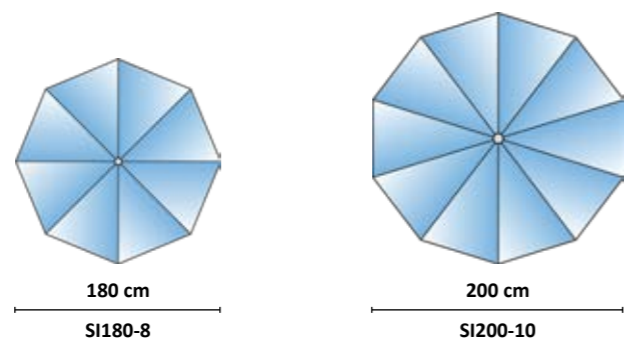

ART.	A	B
SI180-8	210/225 cm	110/125 cm
SI200-10	210/225 cm	105/120 cm

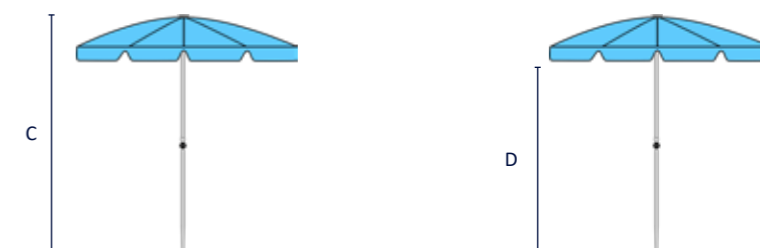

ART.	C	D
SI180-8	210/225 cm	115/195 cm
SI200-10	210/225 cm	115/195 cm

OPTIONAL



IT Prolungo angolare.
EN Corner lower pole.
FR Pique cornière.
DE Eckform Unterstock.



IT Art 352. Base da interrare in alluminio.
EN Art 352. Casting aluminium ground anchor.
FR Art 320. Pied d'ancrage en aluminium.
DE Art. 352. Sockel aus Aluminium.



IT Art. 304X. Base in cemento disegno legno, colore grigio.
EN Art. 304X. Concrete base with wood design, grey colour.
FR Article 304X. Pied en béton avec motif bois, couleur gris.
DE Art. 304X. Betonsockel mit Holzdesign, grau Farbe.



IT Art. 304-38. Base in cemento disegno legno, colore bianco.
EN Article 304-38. Concrete base with wood design, white colour.
FR Article 304-38. Pied en béton avec motif bois, couleur blanc.
DE Artikel 304-38. Betonsockel mit Holzdesign, Weiß Farbe.



IT Fodera di protezione Mytex.
EN Mytex protection cover.
FR Housse de protection en Mytex.
DE Mytex Schutzhülle.



IT Personalizzazione tessuto.
EN Advertising customization.
FR Personnalisation publicitaire.
DE Werbepersonalisierung.

SUPERINOX

IT TESSUTI - DATI TECNICI PAG. 144
EN FABRICS - TECHNICAL DATAS PAG.144

FR TISSUS - DONNÉES TECHNIQUES PAG. 144
DE STOFFE - TECHNISCHE DATEN PAG. 144

ACRILMA



RAYTENT

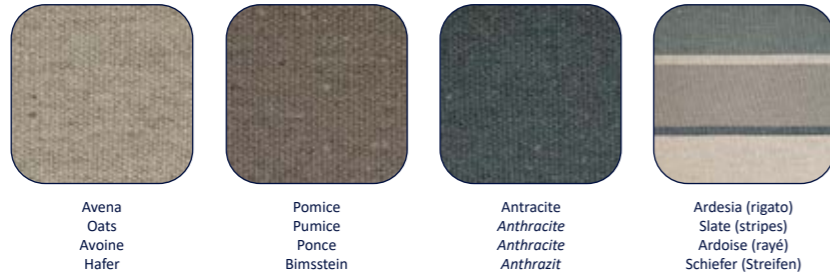

DRALON

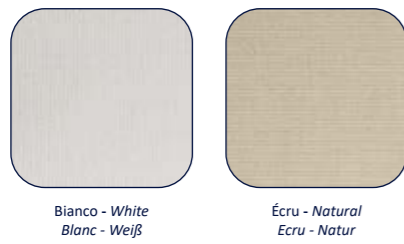

IT **ACCESSORI** EN **ACCESSORIES**
FR **ACCESSOIRES** DE **ZUBEHÖRE**



cm 62x62x0,6 - kg 20

IT Base in acciaio zincato calpestabile, colore bianco e antracite, predisposizione ruote/tasselli/piedini.
EN Walkable galvanized steel base, white and anthracite colour, with holes to assemble wheels/anchors/feet.
FR Pied plaque en acier zingué, couleur blanc et anthracite, prédisposition pour roulettes/tasseaux/pieds.
DE Verzinkter Begehbarer Stahlständer, Weiß und Anthrazitfarben, Vorkerung für Räder/Stecker/Fuß.



Art. 356-BIA-38
tubo/tube/tube/Rohr 38 mm
Art. 356-BIA-45
tubo/tube/tube/Rohr 45 mm
Art. 356-BIA-55
tubo/tube/tube/Rohr 55 mm



Art. 356-GRA-38
tubo/tube/tube/Rohr 38 mm
Art. 356-GRA-45
tubo/tube/tube/Rohr 45 mm
Art. 356-GRA-55
tubo/tube/tube/Rohr 55 mm

cm 62x62x1- kg 30

IT Base in acciaio zincato calpestabile, colore bianco e antracite, predisposizione ruote/tasselli/piedini.
EN Walkable galvanized steel base, white and anthracite colour, with holes to assemble wheels/anchors/feet.
FR Pied plaque en acier zingué, couleur blanc et anthracite, prédisposition pour roulettes/tasseaux/pieds.
DE Verzinkter Begehbarer Stahlständer, Weiß und Anthrazitfarben, Vorkerung für Räder/Stecker/Fuß.



Art. 358-BIA-38
tubo/tube/tube/Rohr 38 mm
Art. 358-BIA-45
tubo/tube/tube/Rohr 45 mm



Art. 358-GRA-38
tubo/tube/tube/Rohr 38 mm
Art. 358-GRA-45
tubo/tube/tube/Rohr 45 mm

cm 62x62x2- kg 60

IT Base in acciaio zincato calpestabile, colore bianco e antracite, predisposizione ruote/tasselli/piedini. Tubo con 4 viti.
EN Walkable galvanized steel base, white and anthracite colour, with holes to assemble wheels/anchors/feet. Tube with 4 screws.
FR Pied plaque en acier zingué, couleur blanc et anthracite, prédisposition pour roulettes/tasseaux/pieds. Tube avec 4 vis.
DE Verzinkter Begehbarer Stahlständer, Weiß und Anthrazitfarben, Vorkerung für Räder/Stecker/Fuß. Rohr mit 4 Schrauben.



Art. 356X-BIA-65
tubo/tube/tube/Rohr 65 mm
Art. 356X-BIA-70
tubo/tube/tube/Rohr 70 mm



Art. 356X-GRA-65
tubo/tube/tube/Rohr 65 mm
Art. 356X-GRA-70
tubo/tube/tube/Rohr 70 mm



IT Piedini.
EN Feets.
FR Pieds.
DE Fuß.



IT Ruote per basi con freno.
EN Wheels for bases with brake.
FR Roulettes pour pieds avec frein.
DE Räder für Fuß mit Bremse.

cm 50x50x3,6 - kg 20

IT Base in cemento, disegno legno, colore grigio, marrone o bianco.
EN Concrete base with wood design, colour grey, brown or white.
FR Pied en béton finition bois, couleur gris, marron ou blanc.
DE Betonplatteständer, Holzeffekt. Farbe grau, braun, weiß.

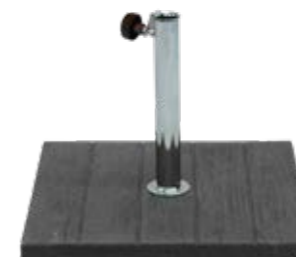

Art. 304-38
tubo/tube/tube/Rohr 38 mm
Art. 304-45
tubo/tube/tube/Rohr 45 mm



Art. 304-MA-38
tubo/tube/tube/Rohr 38 mm
Art. 304-MA-45
tubo/tube/tube/Rohr 45 mm



Art. 304-BIA-38
tubo/tube/tube/Rohr 38 mm
Art. 304-BIA-45
tubo/tube/tube/Rohr 45 mm

cm 50x50x3,6 - kg 20

IT Base in cemento, disegno legno, colore grigio, marrone o bianco, tubo laterale.
EN Concrete base with wood design, colour grey, brown or white, side tube.
FR Pied en béton finition bois, couleur gris, marron ou blanc, tube excentré.
DE Betonplatteständer, Holzeffekt. Farbe grau, braun, weiß. Seitenrohr.



Art. 304B-38
tubo/tube/tube/Rohr 38 mm
Art. 304B-45
tubo/tube/tube/Rohr 45 mm



Art. 304B-MA-38
tubo/tube/tube/Rohr 38 mm
Art. 304B-MA-45
tubo/tube/tube/Rohr 45 mm



Art. 304B-BIA-38
tubo/tube/tube/Rohr 38 mm
Art. 304B-BIA-45
tubo/tube/tube/Rohr 45 mm

cm 50x50x7,2 - kg 40

IT Base in cemento, disegno legno, colore grigio, marrone o bianco. La base è composta da 2 piastre sovrapposte.
EN Concrete base with wood design, colour grey, brown or white. The base is composed by 2 stacked tiles.
FR Pied en béton finition bois, couleur gris, marron ou blanc. Le pied est composé par 2 dalles superposées.
DE Betonplatteständer, Holzeffekt. Farbe grau, braun, weiß. Der Ständer besteht auf 2 überlappenden Platten.

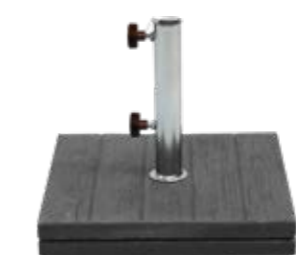

Art. 304X-55
tubo/tube/tube/Rohr 55 mm
Art. 304X-65
tubo/tube/tube/Rohr 65 mm

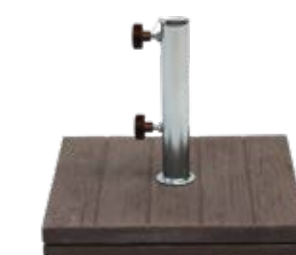

Art. 304X-MA-55
tubo/tube/tube/Rohr 55 mm
Art. 304X-MA-65
tubo/tube/tube/Rohr 65 mm

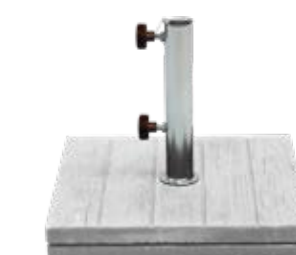

Art. 304X-BIA-55
tubo/tube/tube/Rohr 55 mm
Art. 304X-BIA-65
tubo/tube/tube/Rohr 65 mm



S T A N D A R D

IT Vite di sicurezza in dotazione sulle basi calpestabili in acciaio zincato e in cemento disegno legno.
EN Security screw is standard on steel and wood effect concrete bases.
FR Vis de sécurité standard sur pieds acier et pied béton effet bois.
DE Standard-Sicherheitsschraube ist standard auf Stahlständer und Beton Holzeffekt.



IT **BASI**
FR **PIEDS**

EN **BASES**
DE **FUßE**



Ø cm 44 - kg 25
Art. 302-38

tubo/tube/tube/Rohr 38 mm

Art. 302-45

tubo/tube/tube/Rohr 45 mm

IT Base graniglia.

EN Grit base.

FR Pied en grès.

DE Waschbetonständer.



Ø cm 54 - kg 35
Art. 361

tubo/tube/tube/Rohr 38 mm

Art. 301-45

tubo/tube/tube/Rohr 45 mm

Art. 301-55

tubo/tube/tube/Rohr 55 mm

Art. 301-65

tubo/tube/tube/Rohr 65 mm

Art. 301-75

tubo/tube/tube/Rohr 75 mm

IT Base ghiaia grafite.

EN Graphite gravel base.

FR Pied en gravier graphite.

DE Fuß In Kies, Farbe Graphit.



Ø cm 54 - kg 35
Art. 301-38

tubo/tube/tube/Rohr 38 mm

Art. 301-45

tubo/tube/tube/Rohr 45 mm

Art. 301-55

tubo/tube/tube/Rohr 55 mm

Art. 301-65

tubo/tube/tube/Rohr 65 mm

Art. 301-75

tubo/tube/tube/Rohr 75 mm

IT Base graniglia.

EN Grit base.

FR Pied en grès.

DE Waschbetonständer.



Ø cm 59 - kg 55
Art. 360

IT Base graniglia con maniglie.

EN Granite base on support

liftable with wheels and lever.

FR Pied en granit sur support

relevable avec roues et levier.

DE Mit Rädern und Hebel anhebbar.



Ø cm 59 - kg 55
Art. 310-55

tubo/tube/tube/Rohr 55 mm

Art. 310-65

tubo/tube/tube/Rohr 65 mm

IT Base graniglia con maniglie.

EN Grit base with handles.

FR Pied en grès avec poignées.

DE Waschbetonständer mit Griffen.



Ø cm 65 - kg 75
Art. 311-65

tubo/tube/tube/Rohr 65 mm

IT Base graniglia con maniglie.

EN Grit base with handles.

FR Pied en grès avec poignées.

DE Waschbetonständer mit Griffen.



IT Vite di sicurezza.

EN Security screw.

FR Vis de sécurité.

DE Sicherheitsschraube.



IT **BASI**
FR **PIEDS**

EN **BASES**
DE **FUßE**



Art. 341 cm 90x90

IT Base in acciaio zincato per mattonelle cm 40x40 (fino ad 8 mattonelle). Piastrelloni esclusi.

EN Galvanized steel base for 40x40 cm tiles (up to 8 tiles).

Tiles excluded.

FR Socle en acier galvanisé pour carrelage 40x40 cm (jusqu'à 8 carrelage). Carreaux exclus.

DE Verzinkter Eisensockel für 40x40 cm große Fliesen (bis zu 8). Fliesen ausgeschlossen.



Art. 303 - cm 50x50x3,7 - kg 20

Art. 303/40 - cm 40x40x3.7 - kg 13

IT Piastrellone in graniglia.

EN Dalle en grès.

FR Grit tile.

DE Waschbetonplatte.



Art. 305 - cm 50x50x3,6 - kg 20

IT Piastrellone in cemento disegno legno, colore grigio.

EN Concrete tile with wood

design, grey.

FR Dalle en béton finition bois

couleur gris.

DE Betonplatte, Holzeffekt, farbe

grau.



Art. 305-BIA - cm 50x50x3,6 - kg 20

IT Piastrellone in cemento disegno legno, colore bianco.

EN Concrete tile with wood design, white.

FR Dalle en béton finition bois

couleur blanc.

DE Betonplatte, Holzeffekt, farbe

weiß.



Art. 305-MA - cm 50x50x3,6 - kg 20

IT Piastrellone in cemento disegno legno, colore marrone.

EN Concrete tile with wood design, brown.

FR Dalle en béton finition bois

couleur marron.

DE Betonplatte, Holzeffekt, farbe

braun.



IT Base da interrare in acciaio zincato e verniciato. Profondità cm 38. Adatto a Fibraplus, Vik, Urban.

EN Galvanized and painted steel in-ground base, Depth 38 cm. Suitable for Fibraplus, Vik, Urban.

FR Pied à enterrer en acier galvanisé et peint. Profondeur 38 cm. Adapté à Fibraplus, Vik, Urbain.

DE Sockel aus verzinktem und lackiertem Stahl. Tiefe 38 cm. Geeignet für Fibraplus, Vik, Urban.



Ø cm 44 - kg 27
Art. 320-BIA-27

IT Base in cemento ricoperta plastica, con tubo. Adatta a bastoni ombrelloni mm 33-40.

EN Concrete base covered with plastic, with tube. Fits pole till 40 mm.

FR Pied en béton couvert avec plastique. Adapté à mât jusqu'à 40 mm.

DE Kunststoff abgedeckt Betonständer, mit Rohr. Geeignet für Stock bis 40 mm



Ø cm 44 - kg 54
Art. 320-BIA-54

IT Base in cemento ricoperta plastica, con tubo. Adatta a bastoni ombrelloni mm 33-40.

EN Concrete base covered with plastic, with tube. Fits pole till 40 mm.

FR Pied en béton couvert avec plastique. Adapté à mât jusqu'à 40 mm.

DE Kunststoff abgedeckt Betonständer, mit Rohr. Geeignet für Stock bis 40 mm

O P T I O N A L



Art. 352

IT Base da interrare in alluminio con adattatore per ombrelloni con misura 20-50 mm. Lunghezza puntale cm 31. Lunghezza supporto ombrellone cm 28.

EN Aluminium in-ground base with adaptor for poles size 20-50 mm. Drill length 31cm.

Adaptor length 28 cm.

FR Pied à enterrer en aluminium avec adaptateur pour mâts taille 20-50 mm. Longueur vrille 31 cm.

Longueur adaptateur 28 cm.

DE Alu Sockel für Sonnenschirm mit Adapter für Stock Größe 20-50 mm. Länge Ankerfuß 31 cm

Länge Adapter cm 28.



IT Adattatori Ø 20 A Ø 50.
EN Adapters Ø 20 TO Ø 50.
FR Adaptateurs Ø 20 À Ø 50.
DE Adapter Ø 20 bis Ø 50.



IT Manicotto di avvitamento con livella.
EN Screwing sleeve wit level.
FR Douille à visser avec niveau.
DE Schraubhülse mit Wassewaage.



IT Supporto per ombrellone.
EN Parasol holder.
FR Support parasol.
DE Sonnenschirm Hänger.

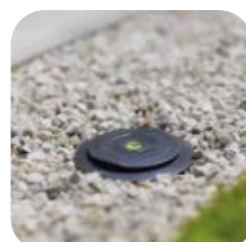

IT Tappo di chiusura.
EN Closing cap.
FR Bouchon de fermeture.
DE Verschlusskappe.



Art. 353

IT Base da interrare in alluminio con adattatore per altre misure pali. Lunghezza puntale cm 31.

EN Aluminium in-ground base with adaptor for other pole sizes. Drill length 31cm.

FR Pied à enterrer en aluminium avec adaptateur pour plusieurs taille du mât. Longueur vrille 31 cm.

DE Alu Sockel für Sonnenschirm mit Adapter für andere Stock Größe . Länge Ankerfuß 31 cm.



IT Supporto per altri fissaggi.
EN Holder for other fixings.
FR Support pour d'autres.
DE Hänger für andere Befestigungen.

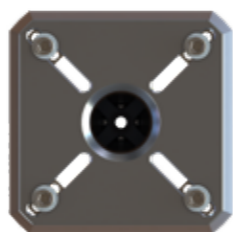

IT Regolazioni varie misure.
EN Various size adjustments.
FR Divers ajustements de taille.
DE Verschiedene Größenanpassungen.

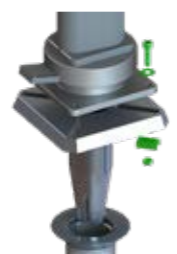

IT Assemblaggio.
EN Assembly.
FR Assemblage.
DE Montage.



IT Esempio.
EN Example.
FR Exemple.
DE Beispiel.





IT **FODERE**
FR **HOUSSES**

EN **COVERS**
DE **SCHUTZHÜLLEN**

IT **TESSUTO:** Mytex a 3 strati accoppiati, tinto in pasta, impermeabile colonna d'acqua, traspirante, dotato di ottima resistenza alla trazione ed alla lacerazione (prova chiodo), di protezione anti UV, di resistenza colori 7. Ha la capacità di lasciare uscire l'umidità, pur essendo impermeabile, garantendo una protezione ottimale da sporco, agenti atmosferici, ruggine, muffe.
PRODUZIONE: cuciture rinforzate con bordo, chiusura con fibbie regolabili o lacci (dipende dal prodotto). **AVVERTENZA:** in caso di acquisto occorre sempre verificare che il prodotto da coprire sia almeno 5 cm più corto e stretto della fodera.

EN **FABRIC:** Mytex 3 coupled layers, solution dyed, water column waterproof, breathable, with very good resistance to textile strength and nail tear strength, anti UV protection, colour fastness 7. This fabric, being waterproof, can let the humidity exit, offering a protection against dirt, bad weather, rust and mould.
FINISHING: reinforced seams with band, closing with adjustable buckles or tie-bands (depending on the item). **ATTENTION:** in case of purchase it's necessary to control that the product to cover is at least 5 cm shorter and narrower than the cover.

FR **TESSU:** Mytex, avec 3 couches couplées, teinté en masse, imperméable colonne d'eau, transpirant, avec optimale résistance à la traction et à la laceration (essai clou), de protection anti UV, avec résistance couleurs 7. Il a la capacité, étant imperméable, de laisser sortir l'humidité, en offrant une protection contre la saleté, les intempéries, la rouille, la moisissure.
FINITIONS: coutures renforcées avec bord, fermeture avec boucles réglables ou lacets (selon produit). **ATTENTION:** en cas d'achat il faut contrôler que le produit à protéger soit au moins 5 cm en longueur et largeur plus petit que la housse.

DE **STOFF:** Mytex 3 Schichten Verbundstoff, Spinnfärbefärbte, Wassersäule, hoch Atmungsaktiv klassifiziert, sehr gut Höckstzugkraft und Weiterreisfestigkeit, UV Schutz, Lichtechtheit 7. Das Gewebe ist beide Wasserabstoßend imprägniert und Atmungsaktiv, so kann Schutz von Schmutz, Witterung, Rost und Schimmel anbieten.
FINISH: verstärker Nähte mit Band, Verstellbarer Verschluss mit Schnalle, oder Band (nach Modell). **ACHTUNG:** beim Kauf, bitte prüfen dass die zu schützenden Objekte mindestens 5 cm engere und kurzen müssen sein.



IT **TESSUTI:** vedere a pag. 144
 EN **FABRICS:** see on pag.144

FR **TESSUS:** voir à pag.144
 DE **STOFF:** siehe auf Seite.144



Art. 920 cm 140x30

IT Fodera per ombrelloni Alfa D200, Permar, Superinox.
 EN Cover for parasols Alfa D200, Permar, Superinox.
 FR Housse pour parasols Alfa D200, Permar, Superinox.
 DE Schutzhülle für Sonnenschirm Alfa D200, Permar, Superinox.

Art. 921BE cm 200x45

IT Fodera per ombrelloni Beta, Alfa D250 e D300.
 EN Cover for umbrellas Beta, Alfa D250, D300.
 FR Housse pour parasols Beta, Alfa D250, D300.
 DE Schutzhülle für Sonnenschirme Beta, Alfa D250, D300..



Art. 920R cm 160x45

IT Fodera per ombrelloni Zanzibar.
 EN Cover for parasols Zanzibar.
 FR Housse pour parasols Zanzibar.
 DE Schutzhülle für Sonnenschirm Zanzibar.



Art. 922TE cm 320x57

IT Fodera per ombrelloni modello James 3x4 e 4x4.
 EN Cover for parasols James 3x4 and 4x4.
 FR Housse pour parasols James 3x4 et 4x4.
 DE Abdeckung für Sonnenschirme James 3x4 und 4x4.



Art. 923 cm 310x75

IT Fodera per ombrellone laterale Fibraplus.
 EN Cover for cantilever Fibraplus.
 FR Housse pour parasol deporté Fibraplus.
 DE Schutzhülle für Ampelschirm Fibraplus.



Art. 922 cm 275/300x57

IT Fodera per ombrelloni Fibramax, Deco.
 EN Cover for parasols Fibramax.
 FR Housse pour parasols Fibramax, Deco.
 DE Schutzhülle für Sonnenschirme Fibramax, Deco.



Art. 925 cm 275/295x55x35

IT Fodera per ombrellone laterale retrattile Vik, Urban.
 EN Cover for retractable side pole umbrella Vik, Urban.
 FR Housse pour parasols deporté rétractable. Vik, Urban.
 DE Schutzhülle for Ampelschirm Vik, Urban.



Art. 922TE cm 320x57

IT Fodera per ombrellone James 3x3 (catalogo Maffei).
 EN Cover for parasol James 3x3 (Maffei catalogue).
 FR Housse pour parasols James 3x3 (Maffei catalogue).
 DE Schutzhülle für Sonnenschirme James 3x3 (Maffei catalogue).



IT Fodera per ombrellone Polo e Prince.
 EN Cover for pole umbrella Polo and Prince.
 FR Housse pour parasols Polo et Prince.
 DE Für Polo und Prince.

IT **TESSUTI**
FR **TISSUS**

EN **FABRICS**
DE **STOFFE**

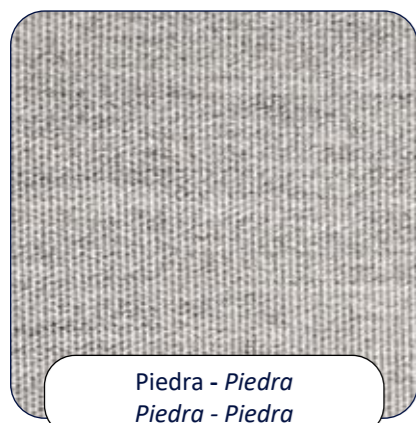
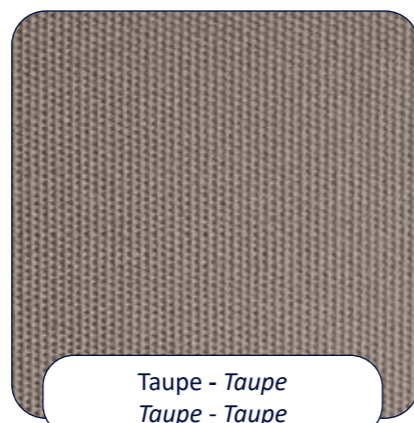
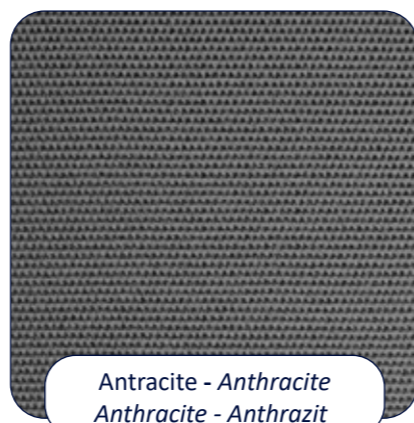

 Piedra - Piedra
Piedra - Piedra

 Taupe - Taupe
Taupe - Taupe

 Antracite - Anthracite
Anthracite - Anthrazit

 Blu - Blue
Bleu - Blau

 Nero - Black
Noir - Schwarz

 Verde - Green
Vert - Grün

 Bianco - White
Blanc - Weiß

 Écru - Natural
Ecrú - Natur

 Giallo - Yellow
Jaune - Gelb

 Bordeaux - Burgundy
Bordeaux - Bordeaux

 Terracotta - Terracotta
Terre cuite - Terracotta

 Brasserie - Brasserie
Brasserie - Brasserie

 IT **TESSUTI SPECIALI ACRILMA**

 EN **ACRILMA SPECIAL DESIGNS**

 FR **DESSINS SPÉCIAUX ACRILMA**

 DE **BESONDERE ACRILMA-DESIGNS**
Twitell

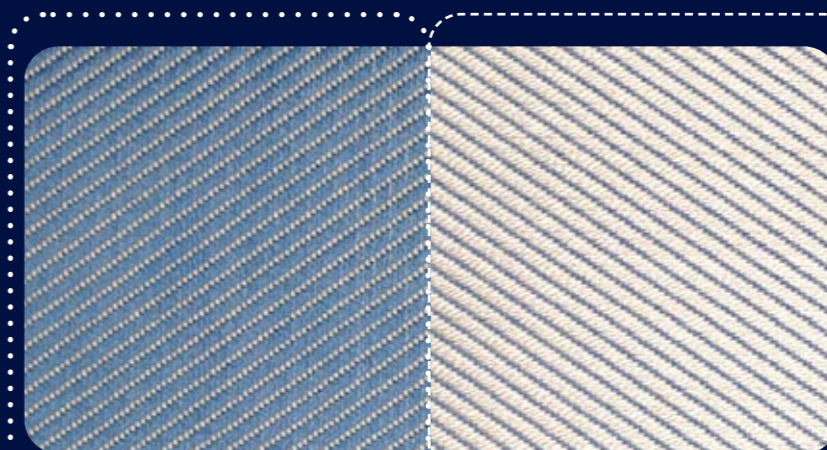
 ○
 Esterno
 Outside
 Extérieur
 Außen

Azzurro - Azur - Azur - Azur

Grigio - Grey - Gris - Grau



Grigio - Grey - Gris - Grau

Grigio - Grey - Gris - Grau

Twitell

 - - - ○
 Interno
 Inside
 Intérieur
 Innen

 Picco bianco/grigio - Picco White/grey
 Picco Blanc/Gris - Picco Weiß/Grau

IT DATI TECNICI

Acrilico tinto pasta gr 270/310, colori garantiti 5 anni, idrorepellente, antimuffa, protezione UV 50+.
I colori ecru, taupe, antracite sono disponibili nel peso gr 310, mentre gli altri colori nel peso gr 270.
L'acrilico tinto pasta è il miglior tessuto per esterni.

EN TECHNICAL FEATURES

*Solution dyed Acrylic 270/310 gr, 5 years colour fastness warranty, water-repellent, mouldproof, UV protection 50+.
The colours natural, taupe, anthracite are supplied in the weight of 310 gr, while the other colours in 270 gr.
The solution dyed Acrylic is the best fabric for outdoor use.*

FR CARACTÉRISTIQUES TECHNIQUES

*Acrylique teinté dans la masse 270/310 gr, couleurs garantis 5 ans, hydrofuge, antimoisissure, protection UV 50+.
Les couleurs ecru, taupe, anthracite sont disponibles dans le poids de gr 310, les autres en 270 gr.
L'acrylique teinté dans la masse est le meilleure tissu pour extérieur.*

DE TECHNISCHE EIGENSCHAFTEN

*Spinndüsengefärbtes Acryl 270/310 gr, 5 Jahre Garantie auf Lichthechtheit, wasserabweisend, schimmelresistent, UV-Schutz 50+.
Die Farben Natur, Taupe und Anthrazit sind in 310 g erhältlich, während die anderen Farben in 270 g erhältlich sind.
Das spinndüsengefärbtes Acryl ist der beste Stoff für Outdoor.*

IT Lavare a 30 gradi
EN 30 degrees wash
FR Lavage à 30 degrés
DE 30 Grad Waschen



IT Lavaggio a mano
EN Handwash
FR Laver à la main
DE Handwäsche

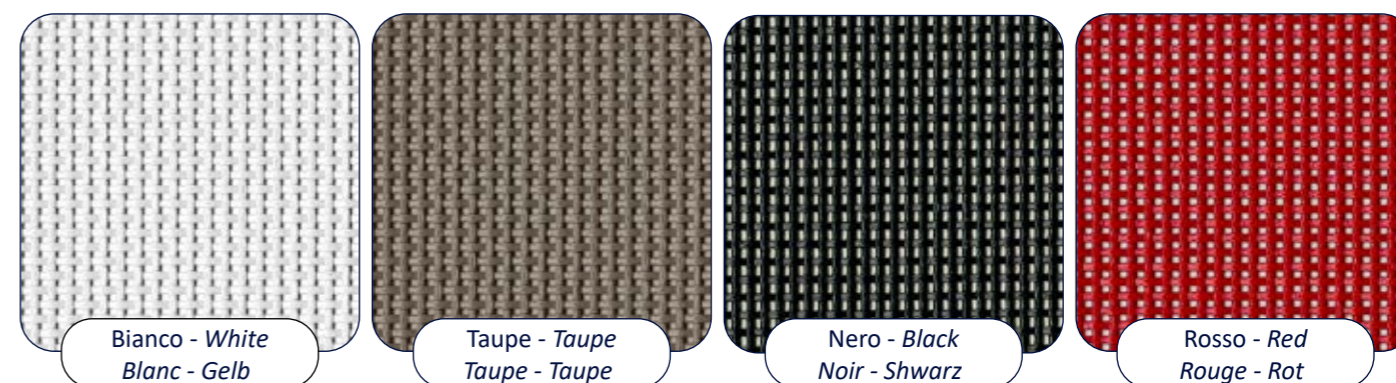

IT DATI TECNICI

Batyline (o simile) gr 560, tessuto ombreggiante, antimuffa, permeabile, colori resistenza 7+, molto resistente a tutte le condizioni climatiche e svolge funzione antivento.

EN TECHNICAL FEATURES

Batyline (or similar), 560 gr, shading fabric, mouldproof, permeable, colour fastness 7+ Highly resistant to various weather conditions, wind-resistant.

FR CARACTÉRISTIQUES TECHNIQUES

Batyline (ou similaire) 560 gr, antimoisissure, perméable, résistance couleur 7+, avec fonction anti-vent.

DE TECHNISCHE EIGENSCHAFTEN

Batyline (oder ähnlich) 560 gr, schimmelresistent, luftdurchlässige Stoff, Lichthechtheit 7+.

IT Lavare a 30 gradi
EN 30 degrees wash
FR Lavage à 30 degrés
DE 30 Grad Waschen



IT Lavaggio a mano
EN Handwash
FR Laver à la main
DE Handwäsche





IT DATI TECNICI

Acrilico tinto pasta RICICLATO, gr 230, colori garantiti 10 anni, idrorepellente, antimuffa, protezione UV 50+.
Questo tessuto viene prodotto attraverso un innovativo processo che utilizza gli sfridi e scarti di produzione dai clienti. Il processo di successiva lavorazione comporta un minor spreco di acqua e minor utilizzo di sostanze chimiche e minori emissioni di Co2 nell'atmosfera. Il tessuto Raytent contiene dal 50 al 70% di fibra riciclata, con prestazioni simili o superiori rispetto al tessuto di partenza.

EN TECHNICAL FEATURES

RECYCLED solution dyed acrylic, 230 gr, colors guaranteed for 10 years, water-repellent, anti-mold, UV protection 50+.
This fabric is produced through an innovative process that uses production waste and scraps from customers. The following process involves less water waste, less use of chemicals and lower CO2 emissions into the atmosphere. Raytent fabric contains 50% to 70% recycled fiber, with similar or superior performance compared to the original fabric.

FR CARACTÉRISTIQUES TECHNIQUES

Acrylique teint en masse RECYCLÉ, 230 g, couleurs garanties 10 ans, imperméable, anti-moisissure, protection UV 50+.
Ce tissu est produit grâce à un processus innovant qui utilise les chutes et les déchets de production des clients. Le processus de traitement ultérieur entraîne une réduction du gaspillage d'eau, moins de consommation de substances chimiques et une diminution des émissions de CO2 dans l'atmosphère. Le tissu Raytent contient de 50 à 70 % de fibres recyclées, avec des performances similaires ou supérieures à celles du tissu d'origine.

DE TECHNISCHE EIGENSCHAFTEN

RECYCELTE Spinnfärbtes Acryl, 230 g, Farben 10 Jahre garantiert, wasserabweisend, schimmelresistent, UV-Schutz 50+.
Dieser Stoff wird durch einen innovativen Prozess hergestellt, der die Produktionsabfälle der Kunden nutzt. Der nachfolgende Verarbeitungsprozess führt zu einem geringeren Wasserverbrauch, einer geringeren Verwendung von Chemikalien und einer geringeren CO2-Emission in die Atmosphäre. Der Raytent-Stoff enthält 50 bis 70 % recycelte Fasern und bietet ähnliche oder bessere Leistungen als der ursprüngliche Stoff.

IT Lavare a 30 gradi
EN 30 degrees wash
FR Lavage à 30 degrés
DE 30 Grad Waschen



IT Lavaggio a mano
EN Handwash
FR Laver à la main
DE Handwäsche

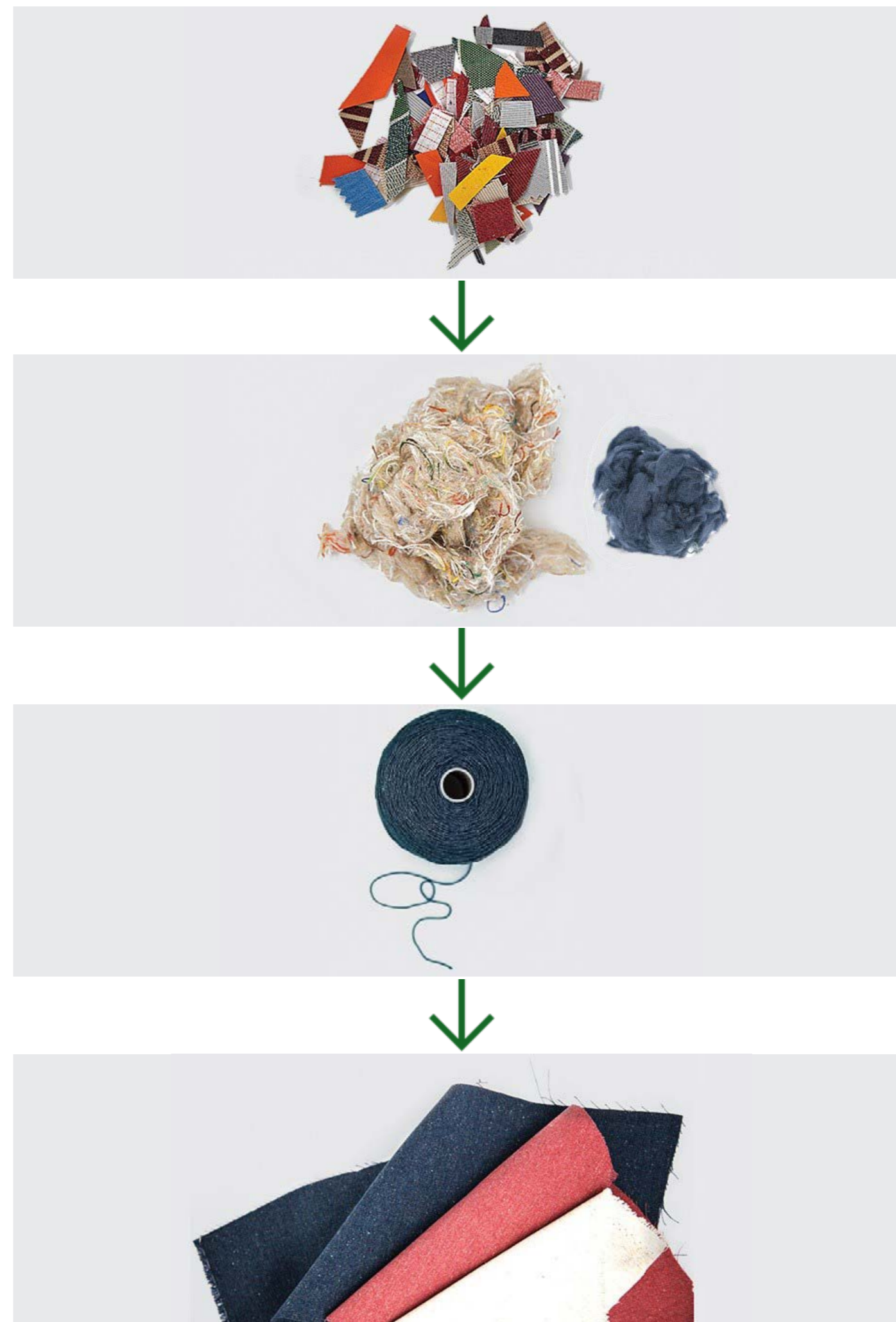

Esterno
Outside
Extérieur
Außen

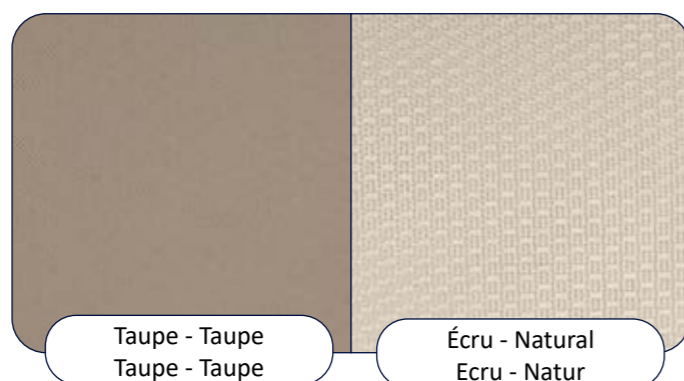

Taupe - Taupe
Taupe - Taupe

Écru - Natural
Ecru - Natur

Interno
Inside
Intérieur
Innen

IT DATI TECNICI

Tessuto poliestere spalmato gr 600, presenta la parte esterna, ricoperta pvc, in colore taupe, mentre la parte interna è in tessuto. Offre un'ottima impermeabilità, ma da sotto non si vede il pvc.

EN TECHNICAL FEATURES

Polyester fabric coated 600g, featuring an outer side coated with taupe PVC, while the inner side is made of fabric. It provides excellent waterproofing, but the PVC is not visible from below.

FR CARACTÉRISTIQUES TECHNIQUES

Tissu en polyester enduit de 600 g, avec une face extérieure revêtue de PVC de couleur taupe, tandis que la face intérieure est en tissu. Il offre une excellente imperméabilité, mais le PVC n'est pas visible par en dessous.

DE TECHNISCHE EIGENSCHAFTEN

Polyester-Gewebe beschichtet mit 600 g, mit einer äußeren Seite, die mit taupefarbenem PVC beschichtet ist, während die Innenseite aus Stoff besteht. Es bietet eine ausgezeichnete Wasserundurchlässigkeit, aber das PVC ist von unten nicht sichtbar.

IT Lavare a 30 gradi
EN 30 degrees wash
FR Lavage à 30 degrés
DE 30 Grad Washen



IT Lavaggio a mano
EN Handwash
FR Laver à la main
DE Handwäsche

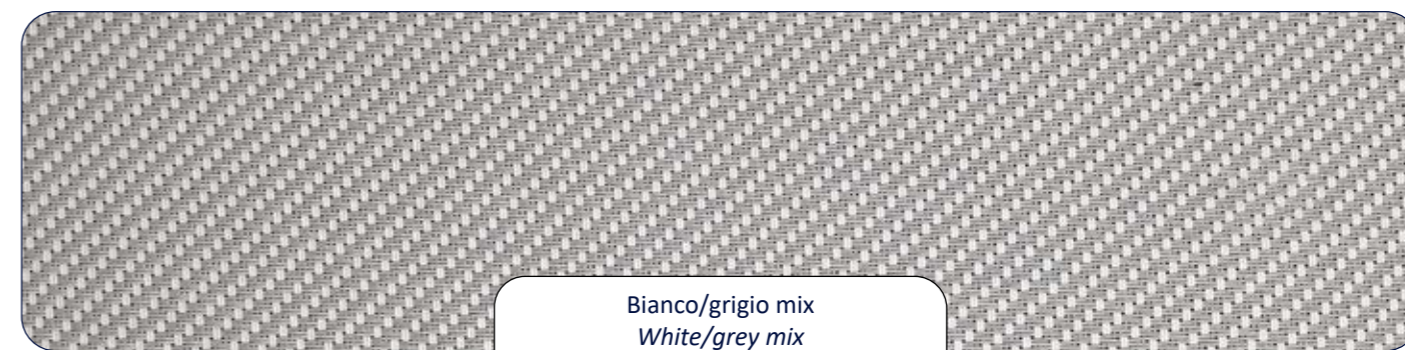

Bianco/grigio mix
White/grey mix
Mélange blanc/gris
Weiß/Grau-Mischung

IT DATI TECNICI

Tessuto filtrante composto da filato in fibra di vetro ricoperto in PVC. Consente di schermare i raggi solari fino al 95% della dannosa componente UV. Peso gr 525.

EN TECHNICAL FEATURES

Screen fabric composed of fiberglass yarn covered in PVC. It allows you to shield up to 95% of the harmful UV component from the sun's rays. Weight gr 525.

FR CARACTÉRISTIQUES TECHNIQUES

Tissu filtrant composé de fils de fibre de verre recouvert en PVC. Il vous permet de protéger jusqu'à 95 % de la composante UV nocive des rayons du soleil. Poids gr 525.

DE TECHNISCHE EIGENSCHAFTEN

Filtergewebe aus Fasergarn PVC-beschichtetes Glas. Es ermöglicht Ihnen, bis zu 95 % des schädlichen UV Anteils vor den Sonnenstrahlen abzuschirmen. Gewicht gr 525.

IT Lavare a 30 gradi
EN 30 degrees wash
FR Lavage à 30 degrés
DE 30 Grad Washen



IT Lavaggio a mano
EN Handwash
FR Laver à la main
DE Handwäsche





Bianco - *White*
Blanc - *Weiß*



Écru - *Natural*
Ecrú - *Natur*



Taupe - *Taupe*
Taupe - *Taupe*



Grigio - *Grey*
Gris - *Grau*



Brasserie - *Brasserie*
Brasserie - *Brasserie*



Nero - *Black Noir*
Schwarz



Blu - *Blue*
Bleu - *Blau*



Terracotta - *Terracotta*
Terre cuite - *Terracotta*



Antracite - *Anthracite*
Anthracite - *Anthrazit*

IT **DATI TECNICI**

Olefin tinto pasta gr 190, idrorepellente, antimuffa, protezione UV 50+, resistenza colori 7.

EN **TECHNICAL FEATURES**

Solution dyed Olefin, weight 190 gr, waterrepellent, mouldproof, Uv protection 50+, colour fastness 7.

FR **CARACTÉRISTIQUES TECHNIQUES**

Olefin teinté en masse, gr 190, hydrofuge, antimoisissure, protection UV 50+, résistance couleurs 7.

DE **TECHNISCHE EIGENSCHAFTEN**

Spindüsengefärbtes Olefin 190 gr, wasserabweisend, schimmelresistent, UV Schutz 50+, Lichtechtheit 7.

IT Lavare a 30 gradi
EN 30 degrees wash
FR Lavage à 30 degrés
DE 30 Grad Waschen



IT Lavaggio a mano
EN Handwash
FR Laver à la main
DE Handwäsche



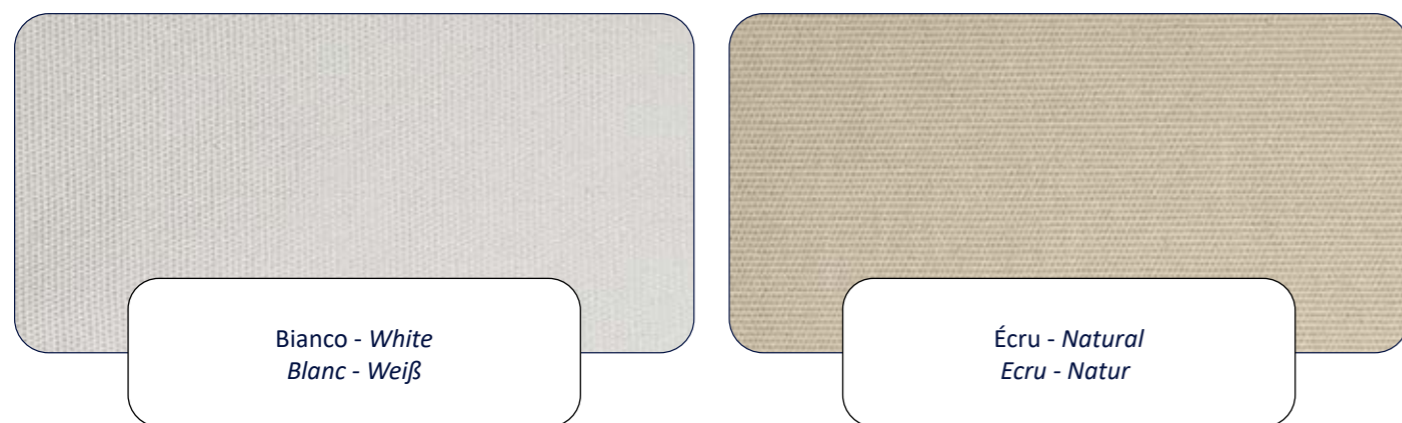

IT DATI TECNICI

Acrilico tinto in filo gr 190, colori resistenza 5/5+, protezione UV 20/50+. E' un ottimo tessuto per esterno, molto confortevole. Viene offerto solo nei colori bianco ed ecru.

EN TECHNICAL FEATURES

Yarn dyed acrylic gr 190, colour fastness 5/5+, UV protection 20/50+. It's an excellent outdoor fabric, very comfortable. It is only available in white and natural colors.

FR CARACTÉRISTIQUES TECHNIQUES

Acrylique teinté en fil de 190 g, résistance aux couleurs 5/5+, protection UV 20/50+. C'est un excellent tissu d'extérieur, très confortable. Il est disponible uniquement en blanc et en écru.

DE TECHNISCHE EIGENSCHAFTEN

190g Acrylgarn gefärbt, Lichtechtheitswert 5/5+, UV-Schutz 20/50+. Es ist ein hervorragendes Outdoor-Gewebe, sehr komfortabel. Es ist nur in den Farben Weiß und Ecru erhältlich.

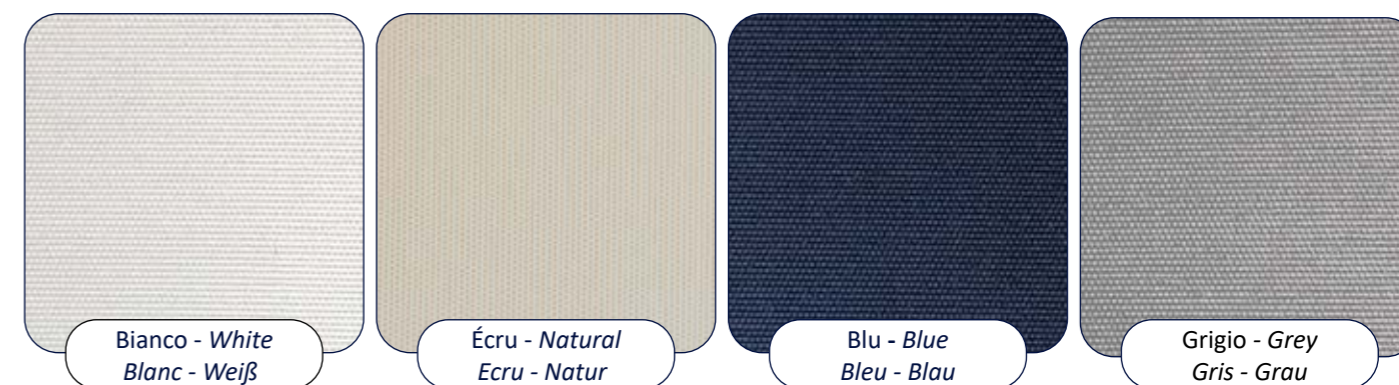
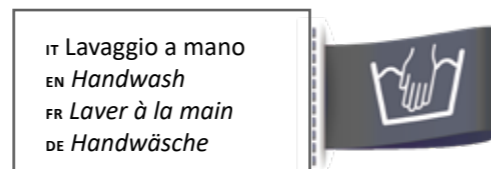
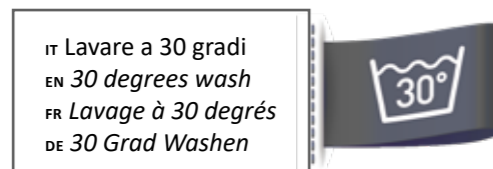

IT DATI TECNICI

PolyMa poliestere gr 210, idrorepellente, antimuffa, protezione UV 50+, resistenza colori 6+.

EN TECHNICAL FEATURES

PolyMa polyester 210 gr, waterrepellent, mouldproof, UV protection 50+, colour fastness 6+.

FR CARACTÉRISTIQUES TECHNIQUES

PolyMa polyester 210 gr, hydrofuge, antimoisissure, protection uv 50+, résistance couleur 6+.

DE TECHNISCHE EIGENSCHAFTEN

PolyMa Polyester 210 gr, wasserabweisend, schimmelresistent, Uv Schutz 50+, Lichtechtheit 6+.

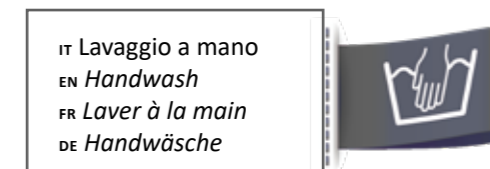
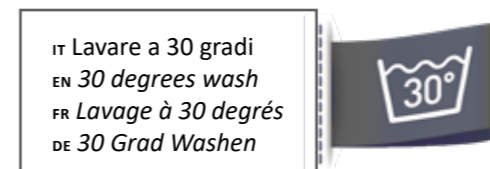

Mytex Standard

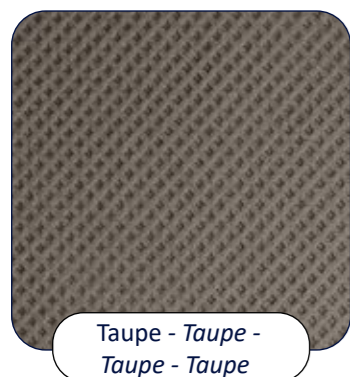

Taupe - Taupe -
Taupe - Taupe

Mytex Plus

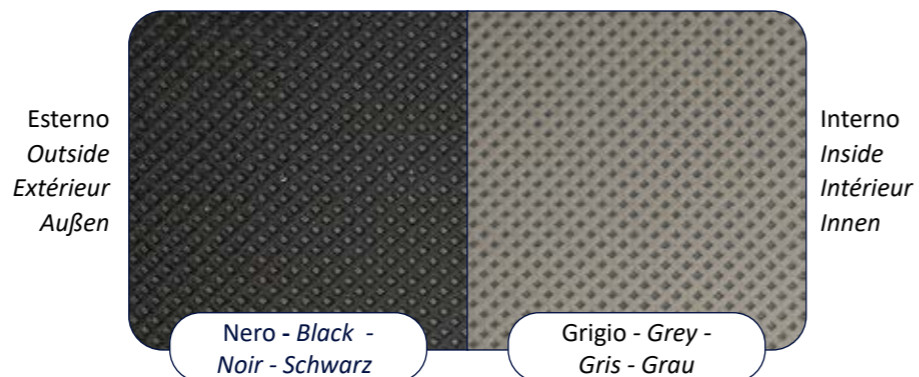

Esterno
Outside
Extérieur
Außen

Interno
Inside
Intérieur
Innen

Nero - Black -
Noir - Schwarz

Grigio - Grey -
Gris - Grau

IT **DATI TECNICI**

TESSUTO: Mytex a 3 strati accoppiati, tinto in pasta, impermeabile colonna d'acqua, traspirante, dotato di ottima resistenza alla trazione ed alla lacerazione (prova chiodo), di protezione anti UV, di resistenza colori 7. Ha la capacità di lasciare uscire l'umidità, pur essendo impermeabile, garantendo una protezione ottimale da sporco, agenti atmosferici, ruggine, muffe.

EN **TECHNICAL FEATURES**

FABRIC: Mytex 3 coupled layers, solution dyed, water column waterproof, breathable, with very good resistance to textile strength and nail tear strength, anti UV protection, colour fastness 7. This fabric, being waterproof, can let the humidity exit, offering a protection against dirt, bad weather, rust and mould.

FR **CARACTÉRISTIQUES TECHNIQUES**

TISSU: Mytex, avec 3 couches couplées, teinté en masse, imperméable colonne d'eau, transpirant, avec optimale résistance à la traction et à la laceration (essai clou), de protection anti UV, avec résistance couleurs 7. Il a la capacité, étant imperméable, de laisser sortir l'humidité, en offrant une protection contre la saleté, les intempéries, la rouille, la moisissure.

DE **TECHNISCHE EIGENSCHAFTEN**

STOFF: Mytex 3 Schichten Verbundstoff, Spinnfärbefärbte, Wassersäule, hoch Atmungsaktiv klassifiziert, sehr gut Hökztzugkraft und Weiterreisfestigkeit, UV Schutz, Lichtechtheit 7. Das Gewebe ist beide Wasserabstoßend imprägniert und Atmungsaktiv, so kann Schutz von Schmutz, Witterung, Rost und Schimmel anbieten.

IT Lavaggio a mano
EN Handwash
FR Laver à la main
DE Handwäsche



A Impermeabile
Imperméable
Waterproof
Undurchlässig

B Raggi UV
Les rayons UV
UV rays & light
UV-Strahlen

C Umidità
Humidité
Humidity
Feuchtigkeit

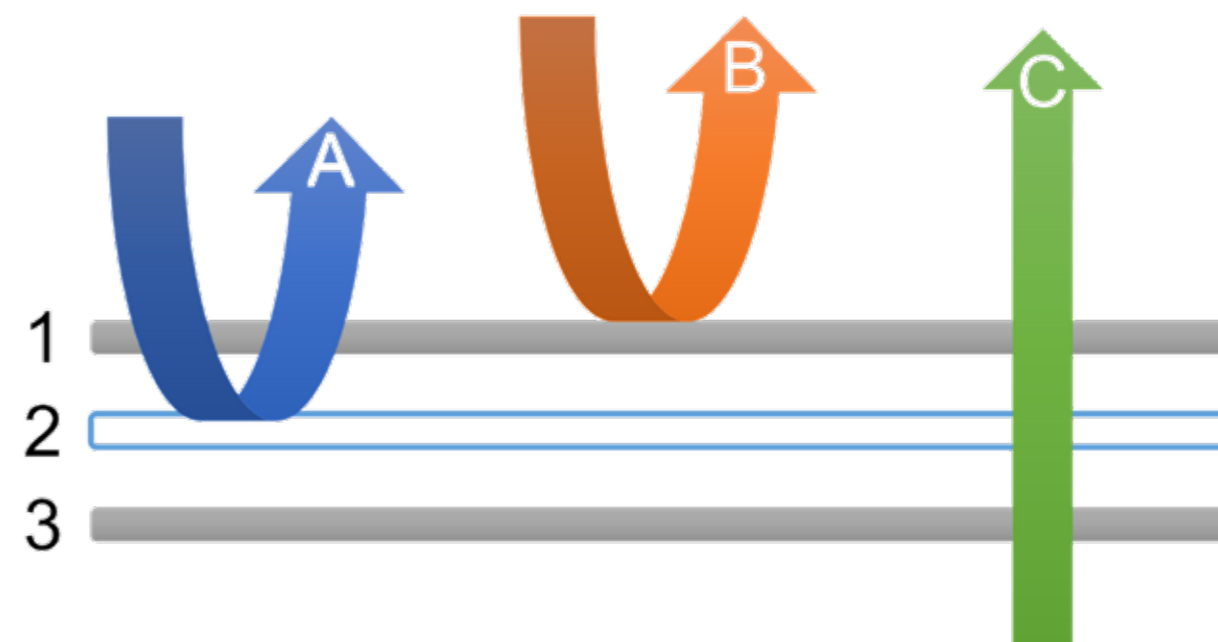

1 Tessuto 1° strato
Tissu 1ère couche
Fabric 1° layer
Stoff 1 Schicht

2 Tessuto 2° strato
Tissu 2ème couche
Fabric 2° layer
Stoff 2 Schicht

3 Tessuto 3° strato
Tissu 3ème couche
Fabric 3° layer
Stoff 3 Schicht

IT SPIEGAZIONE DATI TECNICI CONTENUTI NEL CATALOGO

Peso tessuto: è al m².

Colori: la resistenza è espressa sulla scala il cui valore massimo è 8. Solo i tessuti AcrilMa e Pool della nostra linea professionale MaPro hanno colori garantiti contro lo scolorimento.

Protezione UV: indica la protezione dai raggi UV per le persone. Il valore UPF indicato è secondo la norma AS/NZS il cui valore massimo è 50+ (eccellente).

Dimensione: indichiamo sempre la dimensione tecnica del prodotto, ricavata dalla lunghezza della stecca. La dimensione reale può differire leggermente per effetto della curvatura o per esigenze di lavorazione, ma è sempre inferiore alle tolleranze ammesse.

Peso minimo della base: indichiamo il peso minimo necessario per reggere l'ombrellone in sicurezza in condizioni di montaggio corrette e condizioni meteo normali.

L'ombrellone è sempre venduto senza base. Negli ombrelloni laterali è compresa la struttura metallica della base ma sono esclusi i piastrelloni.

EN PLEASE READ THE FOLLOWING NOTES ON THIS CATALOGUE TECHNICAL DATA.

Fabric weight: it's per m².

Colours: we use a scale where the max value is 8. Just our fabrics AcrilMa and Pool by our commercial collection MaPro are guaranteed against colour fading.

UV Protection: it's the protection against UV rays for the people. The given UPF value follows the rules AS/NZS, which have a max value of 50+ (excellent).

Size: we write the technical dimension, that is the rib length. The actual size can be a little different because of the camber or technical reasons, but it's less than the allowed tolerance.

Base weight: we give the minimum weight in order to hold the parasol in total safety provided correct assembling conditions and normal weather conditions. Our parasols are sold without base. In the side pole parasols the base metal parts are included in the frame, while the tiles/counterweight are not included.

FR EXPLICATION DES DONNÉES TECHNIQUES

Le poids du tissu est au m².

Couleurs: la résistance à la lumière est calculée sur une échelle avec valeur maximale 8. Seulement les tissus AcrilMa et Pool de notre ligne professionnelle MaPro ont la couleur garantie.

Protection UV: indique la protection UV pour les personnes. La valeur indiquée est selon l'échelle AS/NZS, dont la valeur maximale est 50+ (excellent).

Taille: nous mettons toujours la taille technique du produit, obtenue de la longueur de la baleine. La taille réelle du parasol peut être différente à cause de la courbure ou pour besoins de production; elle est toujours inférieure aux tolérances autorisées.

Poids minimum du pied: nous indiquons le poids minimum pour tenir le parasol en sécurité en conditions de météo et utilisation normales.

Le parasol est toujours vendu sans pied. Dans les parasols déportés la structure métallique est comprise.

DE ERKLÄRUNG DER TECHNISCHEN DATEN

Das Gewicht des Gewebes ist pro Quadratmeter.

Farben: die Lichtechtheit wird auf einer technischen Skala berechnet, deren Maximum 8 ist. Nur die AcrilMa und Pool von MaPro Gastro Kollektion Stoffe haben eine garantierte Lichtechtheit.

UV Schutz: zeigt die UV-Beständigkeit für Menschen an. Der angegebene Index ist nach dem AS/NZS Maßstab, deren Maximum 50+ ist. (ausgezeichnet) Größe: wir geben immer die technische Größe an, aus der Länge der Schienen erhalten.

Die effektive Größe kann anders sein, aufgrund der Krümmung oder technischen Gründen; es ist jedoch niedriger als die zulässigen Toleranzen.

Fuss Mindestgewicht: Wir geben das Mindestgewicht an, um den Schirm bei Wetterbedingungen und normalem Gebrauch sicher zu halten- Der Sonnenschirm wird immer ohne Fuss verkauft. In den Ampelschirmen ist die Metallstruktur der Fuss enthalten.

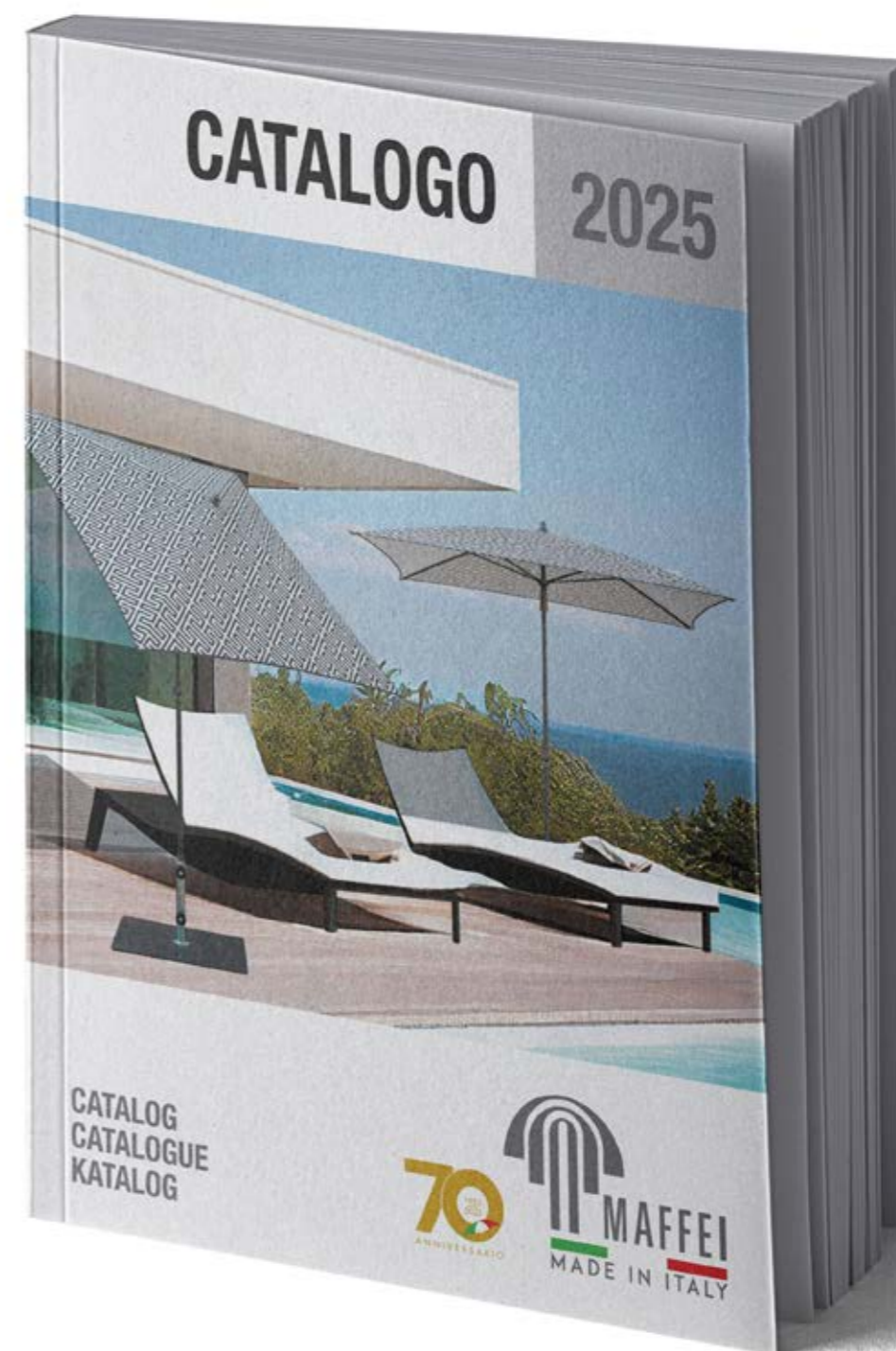

IT VI INFORMIAMO CON PIACERE CHE POTETE CONSULTARE ANCHE IL CATALOGO PER GLI OMBRELLONI AD USO RESIDENZIALE.

EN PLEASE CHECK ALSO THE MAFFEI COLLECTION WITH RESIDENTIAL AND COMMERCIAL QUALITY PARASOLS.

FR MERCI DE DONNER UN COUP D'OEIL AUSSI À NOTRE COLLECTION RESIDENTIELLE.

DE DANKE, DASS SIE AUCH EINEN BLICK AUF UNSERE WOHNKOLLEKTION WERFEN.



IT RINGRAZIAMENTI EN CREDITS FR REMERCIEMENTS DE KREDITE
Agriturismo La Capuccina - Cureggio (NO) - www.lacapuccina.it,
Palazzotto Matera - www.ilpalazzottomatera.it, Comune di Pella (NO)
Castello Dal Pozzo - Oleggio Castello (NO) - www.castellodalpozzo.com,
Adler Spa Resort Sicilia - Siculiana (AG) - www.adler-resorts.com

Realizzato da Webdragons.it

MAFFEI S.R.L. a socio unico

Via Boggia 17/19 - Z.I. Maggiate Superiore
28013 Gattico-Veruno (NO)

Tel. +39.0322.81819

Fax +39.0322.846586

E-mail: maffei@maffeisrl.com

www.maffeisrl.com

www.ombrelloniprofessionali.it

