

CATALOGO

2025



CATALOG
CATALOGUE
KATALOG

70
1953
2023
ANNIVERSARIO

MAFFEI
MADE IN ITALY



Borgomanero, 1935. Maffei Stefano e Vittorio davanti al negozio di famiglia/Maffei Stefano et Vittorio devant la boutique familiale.
Maffei Stefano and Vittorio in front of the family shop/Maffei Stefano und Vittorio vor dem Familienladen.



Borgomanero, 1954. Stabilimento Maffei/Usine Maffei/Maffei facility/Maffei Werk



Gattico-Veruno, 2024. Stabilimento Maffei/Usine Maffei/Maffei facility/Maffei Werk



I primi cataloghi/Les premiers catalogues/The first catalogues/Die ersten Katalogue

“Noi produciamo” / “Nous fabriquons”
 “We produce” / “Wir produzieren”

Maffei è un esempio di industria artigianale

Maffei Srl è un'azienda in grado di offrire una collezione di ombrelloni, basi, cuscini, fodere e vele Made in Italy.

Il nostro obiettivo è proporre articoli di qualità, tecnicamente e stilisticamente all'avanguardia, realizzati con i migliori materiali per soddisfare le diverse esigenze della clientela: molti dei prodotti offerti sono brevettati ed esclusivi, composti da materiali ad alta tecnologia tessile, che li rendono unici sul mercato dell'outdoor.

Ogni anno ci impegniamo ad aggiungere novità e prodotti esclusivi frutto di un attento esame delle nuove esigenze del mercato.



Maffei est en exemple de industrie artisanale

Maffei srl est une entreprise qui offre une collection de parasols, pieds, coussins, housses et voiles made in Italy. Notre but est de proposer des produits de qualité, techniquement et stylistiquement à l'avant-garde, en sélectionnant les meilleurs matériaux avec l'expérience de notre équipe: des produits dans notre catalogue sont notre exclusivité comme design ou technique, qui les font uniques sur le marché. Chaque saison nous nous engageons à ajouter des nouveaux produits pour suivre les tendances.

Maffei is an example of artisanal industry

Maffei srl is a company that can offer a collection of garden and sun umbrellas, bases, protection covers, shade sails, technically and stylistically avant-garde, with the selection of the best materials and the experience of our staff: some products of this catalogue are our exclusivity as design or technique which make them unique on the market. Our goal is to add new products every season to be really up to date.

Maffei ist ein Beispiel von handwerkliche Industrie

Maffei ist eine Firma daß eine Kollektion von Sonnenschirme, Füßen, Aufzügen, Sonnensegeln technisch und stilistisch Avantgarde bietet, mit der Auswahl der besten Lieferanten und der Erfahrung unserer Mitarbeiter: einige Produkte sind unsere Exklusivität wie Design oder Technik, damit sind einzigartig auf dem Markt. Je Saison, versuchen wir Neuigkeiten hinzuzufügen, um immer aktualisiert werden.

INDICE/SOMMAIRE/ INDEX/INHALT

NOVITÀ
 NOUVEAUTE
 NEW
 NEUHEIT
 2025

GREENER  **OMBRELLONE ECOLOGICO**
PARASOL ECOLOGIQUE
ECOLOGICAL PARASOL
SONNENSCHIRM

PIXEL  **OMBRELLONE FANTASY**
PARASOL FANTASY
FANTASY PARASOL
FANTASY SONNENSCHIRM

OMBRELLONI LATERALI
 Parasols déportés
 Side pole parasols
 Ampelschirme



PAG. 8

OMBRELLONI GRANDI
 Grands parasols
 Market parasols
 Marktschirme



GREENER
 PAG. 38

OMBRELLONI DESIGN
 Parasols de design
 Design parasols
 Design Sonnenschirme



PIXEL
 PAG. 60

OMBRELLONI UTILITY
 Parasols utility
 Utility parasols
 Utility Sonnenschirme



PAG. 108

OMBRELLONI CLASSICI
 Parasols classiques
 Classic parasols
 Klassik Sonnenschirme



PAG. 108

FODERE
 Housses
 Covers
 Schutzbezüge



PAG. 140

BASI
 Pieds
 Bases
 Ständer



PAG. 154

VELE
 Voiles d'ombrage
 Shade sails
 Sonnensegel



PAG. 166

CUSCINI
 Coussins
 Cushions
 Polster



PAG. 168



ROTONDI/ ROUNDS

ROUND/RUND

Ø 180	Art. 111	130
	Art. 501  PIXEL	62
Ø 200	Art. 6	126
	Art. 7	126
	Art. 12	120
	Art. 27	88
	Art. 42B	84
	Art. 72	122
	Art. 82	92
	Art. 84	92
	Art. 92	110
	Art. 102K	118
	Art. 102SA	114
	Art. 112	130
Art. 134	80	
Art. 181	136	
Art. 181A	136	
Ø 230/250	Art. 28	88
	Art. 55	104
	Art. 56	104
	Art. 75/6	122
	Art. 114	130
	Art. 135/6	80
	Art. 182A	136
Ø 270/300	Art. P3	34
	Art. 29	88
	Art. 66	96
	Art. 85	92
	Art. 46B	84
	Art. 454	68
	Art. 464	76
	Art. 474	72
	Art. 161  GREENER	48
RETTANGOLARI/RECTANGULAIRES		
RECTANGULAR/RECHTECKIG		
185x125	Art. 113R	132
210x130	Art. 44 BR	84
	Art. 114R	132
240x150	Art. 86R	92
	Art. 106RSA	114
	Art. 136R	80
300x200	Art. 152R	52
	Art. 455R	68
	Art. 475R	72
400x300	Art. 154R	52
	Art. 156R	44
	Art. 176R	40



SEMIQUADRI/ DEMI-CARRÉ

HALF SQUARE/HALB QUADRATISCH

Ø 200	Art. 18	100
QUADRATI/SQUARE		
CARRÉS/ECKIG		
155x155	Art. 113Q	132
	Art. 503Q  PIXEL	62
200x200	Art. 46BQ	84
	Art. 106QSA	114
	Art. 136Q	80
	Art. 453Q	68
	Art. 463Q	76
	Art. 473Q	72
300x300	Art. 505Q  PIXEL	62
300x300	Art. 153Q	52
	Art. 155Q	44
	Art. 175Q	40
	Art. 486Q TE	56

LATERALI QUADRATI/DEPORTES CARRÉS

SIDE POLE/ECKIGE AMPELSCHIRME

200x200	Art. 457Q-200	18
	Art. 467Q-200	27
	Art. 477Q-200	22
250x250	Art. 87Q	14
	Art. 455Q  TREND	68
	Art. 457Q	18
	Art. 467Q	27
	Art. 477Q	22
300x300	Art. 507Q  PIXEL	62
300x300	Art. 448Q	10

LATERALI RETTANGOLARI/DEPORTES RECTANGULAIRES

SIDE POLE RECTANGULAR/RECHTECKIGE AMPELSCHIRME

300x200	Art. 47R	30
	Art. 87R	14
	Art. 457R	18
	Art. 477R	22
300x400	Art. 449R	10

Spiegazione dati tecnici

Peso tessuto: è al mq.

Colori: la resistenza è espressa sulla scala il cui valore massimo è 8. Solo i tessuti AcrilMa e Pool della nostra linea professionale MaPro hanno colori garantiti contro lo scolorimento.

Protezione UV: indica la protezione dai raggi UV per le persone. Il valore UPF indicato è secondo la norma AS/NZS il cui valore massimo è 50+ (eccellente).

Dimensione: indichiamo sempre la dimensione tecnica del prodotto, ricavata dalla lunghezza della stecca. La dimensione reale può differire leggermente per effetto della curvatura o per esigenze di lavorazione, ma è sempre inferiore alle tolleranze ammesse

Peso minimo della base: indichiamo il peso minimo necessario per reggere l'ombrellone in sicurezza in condizioni di montaggio corrette e condizioni meteo normali.

L'ombrellone è sempre venduto senza base. Negli ombrelloni laterali è compresa la struttura metallica della base ma sono esclusi i piastrelloni.

Explication des données techniques

Le poids du tissu est au mc.

Couleurs: la résistance à la lumière est calculée sur une échelle avec valeur maximale 8. Seulement les tissus AcrilMa et Pool de notre ligne professionnelle MaPro ont la couleur garantie.

Protection UV: indique la protection UV pour les personnes. La valeur indiquée est selon l'échelle AS/NZS, dont la valeur maximale est 50+ (excellent).

Taille: nous mettons toujours la taille technique du produit, obtenue de la longueur de la baleine. La taille réelle du parasol peut être différente à cause de la courbure ou pour besoins de production; elle est toujours inférieure aux tolérances autorisées.

Poids minimum du pied: nous indiquons le poids minimum pour tenir le parasol en sécurité en conditions de météo et utilisation normales.

Le parasol est toujours vendu sans pied. Dans les parasols déportés la structure métallique est comprise.

Please read the following notes on the technical datas

Fabric weight: it's per sqm

Colours: we use a scale where the max value is 8. Just our fabrics AcrilMa and Pool by our commercial collection MaPro are guaranteed against colour fading.

UV Protection: it's the protection against UV rays for the people. The given UPF value follows the rules AS/NZS, which have a max value of 50+ (excellent).

Size: we write the technical dimension, that is the rib length. The actual size can be a little different because of the camber or technical reasons, but it's less than the allowed tolerance.

Base weight: we give the minimum weight in order to hold the parasol in total safety provided correct assembling conditions and normal weather conditions. Our parasols are sold without base. In the side pole parasols the base metal parts are included in the frame, while the tiles/counterweight are not included.

Erklärung der technischen Daten

Das Gewicht des Gewebes ist pro Quadratmeter

Farben: die Lichtechtheit wird auf einer technischen Skala berechnet, deren Maximum 8 ist. Nur die AcrilMa und Pool von MaPro Gastro Kollektion Stoffe haben eine garantierte Lichtechtheit.

UV Schutz: zeigt die UV-Beständigkeit für Menschen an. Der angegebene Index ist nach dem AS/NZS Maßstab, deren Maximum 50+ ist. (ausgezeichnet) Größe: wir geben immer die technische Größe an, aus der Länge der Schienen erhalten.

Die effektive Größe kann anders sein, aufgrund der Krümmung oder technischen Gründen; es ist jedoch niedriger als die zulässigen Toleranzen.

Fuss Mindestgewicht: Wir geben das Mindestgewicht an, um den Schirm bei Wetterbedingungen und normalem Gebrauch sicher zu halten- Der Sonnenschirm wird immer ohne Fuss verkauft. In den Ampelschirmen ist die Metallstruktur der Fuss enthalten.

OMBRELLONI LATERALI

Una collezione che soddisfa
le molteplici necessità
dell'arredamento
degli spazi esterni.

PARASOLS DEPORTES

*Une collection variée
pour meubler tout type
d'extérieur.*

SIDE POLE PARASOLS

*A varied collection
to furnish
your outdoors.*

AMPELSCHIRME

*Eine Serie, die viele
unterschiedliche
Anforderungen
für die Einrichtung
von Außenbereichen erfüllt.*



ANTIBES



Art. 448Q cm 300x300/8

Art. 449R cm 300x400/8



Art. 448Q ECRU/NATURAL/NATUR

ANTIBES

Art. 448Q

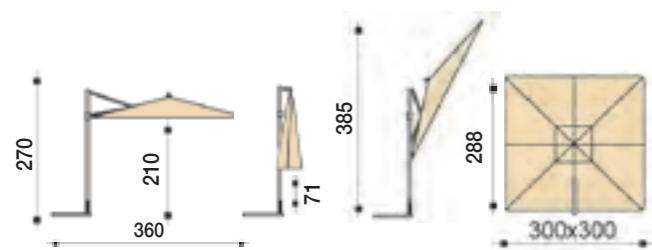

Art. 449R

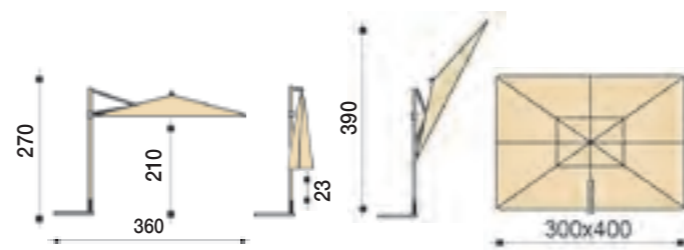

Ombrellone laterale retrattile in alluminio, telaio colore grafite, palo e maniglione alluminio, manovella, inclinabile, girevole, base a X, tessuto PolyMa idrorepellente.

Parasol déporté rétractable structure couleur graphite, mât et poignée en alu, manivelle, inclinable, pivotant, pied en X, tissu PolyMa hydrofuge.

Folding side pole parasol, graphite colour frame, aluminium pole and big handle, crank tiltable, rotating, X-shaped base, PolyMa water-repellent fabric.

Klappbare Ampelschirm mit Graphitfarbenen Gestell, Alu Stock und griff, Kurbel, knickbar, drehbar, X-Fuß, Polyma Stoff. Wasserabstoßend imprägniert.



■ Bacchette ed accessori
■ Baleines et accessoires
■ Ribs and accessories
■ Streben und Zubehör



■ Maniglia in alluminio
■ Poignée en alu
■ Aluminium handle
■ Griff aus Aluminium



■ Bacchetta
■ Baleine
■ Rib
■ Schiene



■ **Optional** consigliato:
Art. 922T fodera in Mytex
■ **Option** conseillée:
Art. 922T Housse en Mytex
■ **Recommended option:**
Art. 922T Mytex cover
■ **Empfohlene Option:**
Art. 922T Schutzülle aus Mytex



■ Base a X c/pedale
■ Pied en X avec pédal
■ X-shaped base with pedal
■ X-form Fuß mit pedal



Antibes Ombrellone laterale retrattile in alluminio

CARATTERISTICHE TECNICHE

TESSUTO: PolyMa poliestere gr 210 mq, idrorepellente, antimuffa, protezione UV 50+, resistenza colori 6+.

STRUTTURA: palo in alluminio colore grafite mm 60x88, apertura con maniglione in alluminio e manovella, inclinabile, base a X con sistema di rotazione a pedale.

Antibes Parasol déporté rétractable en alu

CARACTÉRISTIQUES TECHNIQUES

TISSU: PolyMa Polyester, gr 210 mc, hydrofuge, anti-moisissure, protection UV 50+, résistance couleurs 6+.

STRUCTURE: mât en alu couleur graphite 60x88 mm, ouverture avec poignée en alu et manivelle, inclinable, pied en X avec système de rotation à pédal.

Antibes Alu folding side pole parasol

TECHNICAL FEATURES

FABRIC: PolyMa Polyester gr 210 sm, water-repellent, mouldproof, UV protection 50+, colour fastness 6+.

FRAME: aluminium pole graphite colour 60x88 mm, opening with aluminium handle and crank, tiltable, X-shaped steel base, with pedal rotation system

Antibes Klappbare Ampelschirm aus Aluminium

TECHNISCHE EIGENSCHAFTEN

STOFF: PolyMa Polyester gr 210 qm, Wasserabstoßend imprägniert, Verrottungsfest, Uv Schutz 50+, Lichtechtheit 6+.

GESTELL: Stock aus Alu, Farbe Graphit, 60x88 mm, Öffnung mit Alu Griff und Kurbel, Knickbar, Stahl X-Plattenständer, um 360° drehbar, mit Pedal.

kg Contrappeso per base: min kg 80 per 300x300 e 300x400. Con contrappeso maggiore avrete più stabilità e sicurezza. Mattonelle escluse. **Vedere contrappesi pag. 154**

kg Contrepoids pour pied: min 80 kg pour 300x300 et 300x400. Avec plus de poids il y aura une majeure stabilité et sécurité. Dalles non incluses. **Voir contrepoids à la page 154**

kg Counterweight for base: min 80 kg for 300x300 and 300x400. With higher counterweight, there are better stability and safety. Tiles not included. **See counterweights on page 154**

kg Gegengewicht für Ständer: min 80 kg für 300x300 und 300x400. Mit höher Gegengewicht, es gibt besser stabilität und Sicherheit. Betonplatte nicht enthalten. **Gegengewicht Seite 154**

Colori/Couleurs/Colours/Farben



Colori su richiesta/Couleurs sur demande/Colours on demand/Farben auf Anfrage



ALLEGRO



Art. 87Q cm 250x250/4

Art. 87R cm 300x200/4



Art. 87R BIANCO/BLANC/WHITE/WEISS

Art. 87Q / 87R

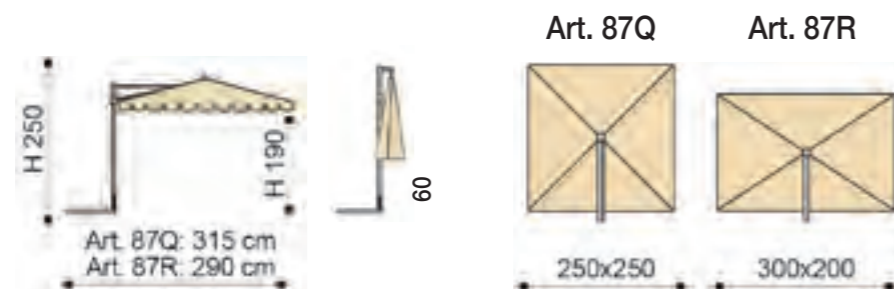

Ombrellone laterale di design retrattile e compatto con struttura colore grafite, apertura senza corde e/o manovelle, girevole, base a T. Design esclusivo Allegro by Maffei con pendente smerlato.

Parasol déporté de design rétractable et compact, structure couleur graphite, ouverture sans cordes et/ou manivelles, pivotant, pied en T. Design exclusif Allegro by Maffei avec lambrequin festonné.

Folding and compact aluminium side pole parasol, graphite colour frame, opening without handle nor crank, rotating, T-shaped base. Exclusive Design Allegro by Maffei with scalloped valance.

Klappbare und kompakt Ampelschirm, Graphitfarbenen Gestell, Öffnung ohne Seil oder Kurbel, drehbar, T-Fuß. Exclusives Design Allegro by Maffei mit festoniertem Volant.

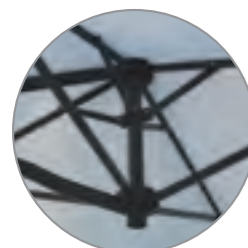

■ Struttura colore grafite
■ Structure couleur graphite
■ Graphite colour frame
■ Gestell Farbe Graphit



■ Manopola alluminio
■ Poignée alu
■ Aluminium handle
■ Griff aus Aluminium



■ Sistema di rotazione
■ Système pivotant
■ Rotating system
■ Rotationssystem



■ Volante smerlato
■ Lambrequins festonnés
■ Scalloped valances
■ Festonierter Volants



■ **Optional** consigliato:
Art. 922 fodera in Mytex
■ **Option** conseillée:
Art. 922 Housse en Mytex
■ **Recommended option:**
Art. 922 Mytex cover
■ **Empfohlene Option:**
Art. 922 Schutzhülle aus Mytex



■ **Opzione:** Art. 353 base da interrare
■ **Option:** Art. 353 pied à enterrer
■ **Option:** Art. 353 in-ground base
■ **Option:** Art. 353 Sockel

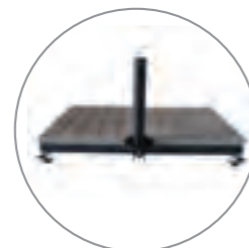

■ **Optional:** base con ruote
■ **Option:** pied avec roulettes
■ **Option:** base with wheels
■ **Option:** Fuß mit räder



■ Base a T
■ Pied en T
■ T-shaped base
■ T-form Fuß

Allegro Ombrellone laterale retrattile

CARATTERISTICHE TECNICHE

TESSUTO: PolyMa poliestere gr 210 mq, idrorepellente, antimuffa, protezione UV 50+, resistenza colori 6+.
TexMa Olefin gr 190 mq, tinto in pasta, idrorepellente, antimuffa, protezione UV 50+, resistenza colori 7.
Il tessuto TexMa può essere usato per alcuni colori speciali. (T).

STRUTTURA: palo in alluminio mm 50x78, struttura colore grafite, bacchette acciaio, maniglia d'apertura in alluminio con fermo di sicurezza, base a T con sistema di rotazione a 360°. Sistema d'apertura esclusivo Maffei senza corde e manovelle. La base può essere messa davanti o dietro al palo e può essere dotata di ruote.

Allegro Parasol déporté rétractable

CARACTÉRISTIQUES TECHNIQUES

TISSU: PolyMa polyester, gr 210 mc, hydrofuge, anti-moisissure, protection UV 50+, résistance couleurs 6+.
TexMa Olefin gr 190 mc, teinté en masse, hydrofuge, anti-moisissure, protection UV 50+, résistance couleurs 7.
Le tissu TexMa peut être utilisé pour des couleurs spéciales (T).

STRUCTURE: mât en alu 50x78 mm, structure couleur graphite, baleines acier, poignée d'ouverture en alu avec fermeture de sécurité, pied en T pivotant à 360°. Système d'ouverture exclusivité Maffei sans cordes ni manivelles. Le pied peut être placé devant ou derrière le mât et peut avoir des roulettes.

Allegro Folding side pole parasol

TECHNICAL FEATURES

FABRIC: PolyMa polyester, gr 210 sm, water-repellent, mouldproof, UV protection 50+, colour fastness 6+.
TexMa solution dyed Olefin gr 190 sm, water-repellent, mouldproof, UV protection 50+, colour fastness 7.
The fabric TexMa can be used for some special colours.

FRAME: Alu pole 50x78 mm graphite colour frame, steel ribs, alu opening handle with safety stopper, T-shaped steel base, 360° rotating. The opening system without ropes nor crank is Maffei's exclusivity. The base can be placed behind or in front of the pole and can have wheels.

Allegro Klappbare Ampelschirm

TECHNISCHE EIGENSCHAFTEN

STOFF: PolyMa Polyester, gr 210 qm, Wasserabstoßend imprägniert, Verrottungsfest, UV Schutz 50+, Lichtehtheit 6+.
TexMa Olefin gr 190 qm spindüsengefärbtes, Wasserabstoßend imprägniert, Verrottungsfest, UV Schutz 50+, Lichtehtheit 7.

GESTELL: Stock 50x78 mm aus Aluminium, Gestell Graphitfarbe, Stahlstreben, Aluminium Griff mit Sicherheit, T-Fuß aus Stahl um 360° drehbar. Das Öffnungssystem ohne Seilzug oder Kurbel ist Exklusivität von Maffei. Der Fuß kann vor oder hinter des Stocks platziert werden und kann Räder haben.

kg Contrappeso per base: min kg 40. Occorre raddoppiare il contrappeso in caso di base con ruote.
Mattonelle escluse. **Vedere contrappesi pag. 154**

kg Contrepoids pour pied: min 40 kg. Il faut doubler le contrepoids en cas de pied avec roulettes.
Dalles non incluses. **Voir contrepoids à la page 154**

kg Counterweight for base: min 40 kg. It's necessary to double up the counterweight in case of base with wheels.
Tiles not included. **See counterweights on page 154**

kg Gegengewicht für Ständer: min 40 kg. Es ist notwendig die Gegengewicht zu verdoppeln im Falle von Fuß mit Räder.
Betonplatte nicht enthalten. **Gegengewicht Seite 154**

Colori/Couleurs/Colours/Farben Art 87Q



Colori/Couleurs/Colours/Farben Art 87R



TREND



Art. 457Q-200 cm 200x200/4

Art. 457Q cm 250x250/4

Art. 457R cm 300x200/4



Art. 457Q ANTRACITE/ANTHRACITE/ANTHRAZIT

TREND

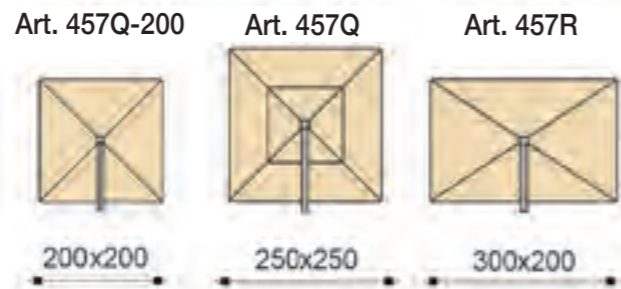
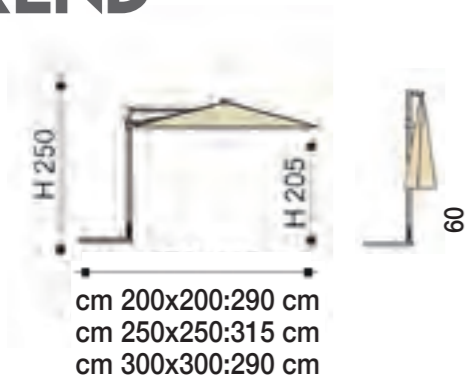

cm 200x200:290 cm
cm 250x250:315 cm
cm 300x300:290 cm



- Ombrellone laterale di design **retrattile** e compatto con struttura colore **grafite**, apertura senza corde e/o manovelle, girevole, base a T.
- Parasol déporté de design **rétractable** et compact, structure couleur **graphite**, ouverture sans cordes ni manivelles, pivotant, pied en T.
- Folding** and compact aluminium side pole parasol, **graphite** colour frame, opening without handle nor crank, rotating, T-shaped base.
- Klappbarer** und kompakter Ampelschirm, **Graphitfarbenen** Gestell, Öffnung ohne Seil oder Kurbel, drehbar, T-Fuß.



- Struttura colore grafite
- Structure couleur graphite
- Graphite colour frame
- Gestell Farbe Graphit



- Manopola alluminio
- Poignée alu
- Aluminium handle
- Griff aus Aluminium



- Sistema di rotazione
- Système pivotant
- Rotating system
- Rotationssystem



- Optional** consigliato:
Art. 922 fodera in Mytex
- Option** conseillée:
Art. 922 Housse en Mytex
- Recommended option:**
Art. 922 Mytex cover
- Empfohlene Option:**
Art. 922 Schutzhülle aus Mytex



- Optional:** base con ruote
- Option:** pied avec roulettes
- Option:** base with wheels
- Option:** Fuß mit Räder



- Opzione:** Art. 353 base da interrare
- Option:** Art. 353 pied à enterrer
- Option:** Art. 353 in-ground base
- Option:** Art. 353 Sockel



- Base a T
- Pied en T
- T-shaped base
- T-form Fuß

Trend Ombrellone laterale retrattile grafite

CARATTERISTICHE TECNICHE

TESSUTO: PolyMa poliestere gr 210 mq, idrorepellente, antimuffa, protezione UV 50+, resistenza colori 6+.
TexMa Olefin gr 190 mq, tinto in pasta, idrorepellente, antimuffa, protezione UV 50+, resistenza colori 7. Il tessuto TexMa può essere usato per alcuni colori speciali. (T).

STRUTTURA: palo in alluminio mm 50x78, bacchette acciaio, maniglia d'apertura in alluminio con fermo di sicurezza, base a T con sistema di rotazione a 360°. Sistema d'apertura esclusivo Maffei senza corde e manovelle. La base può essere messa davanti o dietro al palo e può essere dotata di ruote.

Trend Parasol déporté rétractable graphite

CARACTÉRISTIQUES TECHNIQUES

TISSU: PolyMa polyester, gr 210 mc, hydrofuge, anti-moisissure, protection UV 50+, résistance couleurs 6+.
TexMa Olefin gr 190 mc, teinté en masse, hydrofuge, anti-moisissure, protection UV 50+, résistance couleurs 7.
Le tissu TexMa peut être utilisé pour des couleurs spéciales (T).

STRUCTURE: mât en alu 50x78 mm, baleines acier, poignée d'ouverture en alu avec fermeture de sécurité, pied en T pivotant à 360°. Système d'ouverture exclusivité Maffei sans cordes ni manivelles. Le pied peut être placé devant ou derrière le mât et peut avoir des roulettes.

Trend Graphite frame folding side parasol

TECHNICAL FEATURES

FABRIC: PolyMa polyester, gr 210 sm, water-repellent, mouldproof, UV protection 50+, colour fastness 6+.
TexMa solution dyed Olefin gr 190 sm, water-repellent, mouldproof, UV protection 50+, colour fastness 7. The fabric TexMa can be used for some special colours (T).

FRAME: Aluminium pole 50x78 mm, steel ribs, aluminium opening handle with safety stopper, T-shaped steel base, 360° rotating. The opening system without ropes nor crank is Maffei's exclusive. The base can be placed behind or in front of the pole and can have wheels.

Trend Graphit Farbe Klappbarer Ampelschirm

TECHNISCHE EIGENSCHAFTEN

STOFF: PolyMa Polyester, gr 210 qm, Wasserabstoßend imprägniert, Verrottungsfest, UV Schutz 50+, Lichtehtheit 6+.
TexMa Olefin gr 190 qm spindüsengefärbted, Wasserabstoßend imprägniert, Verrottungsfest, Uv Schutz 50+, Lichtehtheit 7.
TexMa Stoff kann für besonders Farben benutzen sein (T)

GESTELL: Stock aus Aluminium 50x78 mm, Aluminium Griff mit Sicherheit, T-Fuß aus Stahl um 360° drehbar. Das Öffnungssystem ohne Seilzug oder Kurbel ist Exklusivität von Maffei. Der Fuß kann vor oder hinter des Stock platziert werden und kann Räder haben.

Contrappeso per base: min kg 40. Occorre raddoppiare il contrappeso in caso di base con ruote.
Mattonelle escluse. **Vedere contrappesi pag. 154**

Contrepoids pour pied: min 40 kg. Il faut doubler le contrepoids en cas de pied avec roulettes.
Dalles non incluses. **Voir contrepoids à la page 154**

Counterweight for base: min 40 kg. It's necessary to double up the counterweight in case of base with wheels.
Tiles not included. **See counterweights on page 154**

Gegengewicht für Ständer: min 40 kg. Es is notwendig die Gegengewicht zu verdoppeln im Falle von Fuß mit Räder.
Betonplatte nicht enthalten. **Gegengewicht Seite 154**

Colori/Couleurs/Colours/Farben Art 457Q - 200/457Q/457R

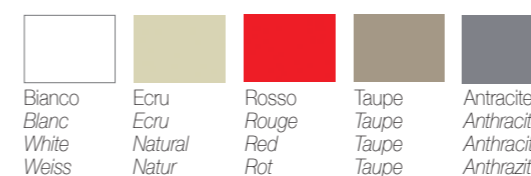

Bianco
Blanc
White
Weiss
Ecu
Ecr
Natural
Natur
Rosso
Rouge
Red
Rot
Taupe
Taupe
Taupe
Taupe
Antracite
Anthracite
Anthracite
Anthrazit

Colori su richiesta/Couleurs sur demande/Colours on demand/ Farben auf Anfrage Art 457Q/457R



Giallo
Jaune
Yellow
Gelb
Arancio
Orange
Orange
Orange
Verde
Vert
Green
Grün
Azzurro
Azur
Sky Blue
Hellblau
Blu
Bleu
Blue
Blau
Nero
Noir
Black
Schwarz
Melange Cenere
Melange Cendre
Melange Ash
Melange Aschen

TREND WOOD



Art. 477Q-200 cm 200x200/4

Art. 477Q cm 250x250/4



Art. 477Q TAUPE

TREND WOOD

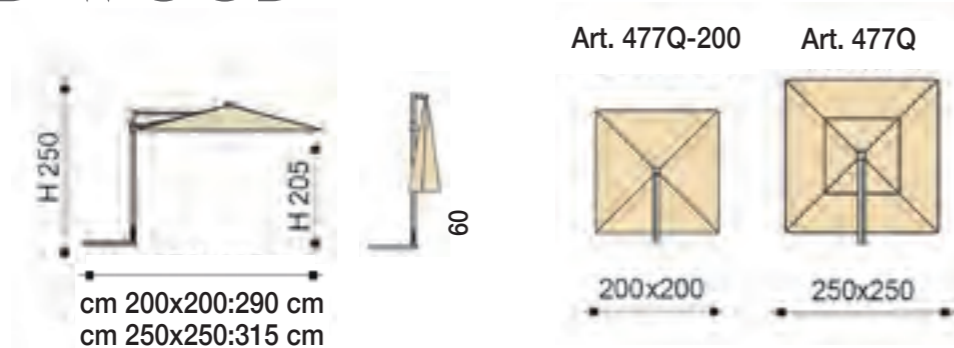

Ombrellone laterale retrattile e compatto, esclusiva Maffei, con telaio palo alluminio **effetto legno**, struttura colore grafite, apertura senza corde e/o manovelle, girevole, base a T, tessuto PolyMa idrorepellente.

Parasol déporté rétractable et compact, exclusivité Maffei, avec mât alu **effet bois**, structure couleur graphite, ouverture sans cordes et/ou manivelles, pivotant, pied en T, tissu PolyMa hydrofuge.

Folding and compact aluminium side pole parasol, Maffei exclusivity, with **wood look** aluminium pole, graphite colour frame, opening without handle nor crank, rotating, T-shaped base, PolyMa water-repellent fabric.

Klappbarer und kompakter Ampelschirm, exclusivität Maffei, mit **Holzoptik**-Alu Stock, Graphitfarbenen Gestell, Öffnung ohne Seil oder Kurbel, drehbar, T-Fuß, PolyMa Stoff. Wasserabweisend imprägniert



■ Struttura colore grafite
■ Structure couleur graphite
■ Graphite colour frame
■ Gestell Farbe Graphit



■ Palo alluminio effetto legno con manopola alluminio grafite
■ Mât alu effet bois avec poignée alu graphite
■ Wood look aluminium pole with graphite aluminium handle
■ Holzoptik Stock und Griff aus Aluminium



■ Sistema apertura
■ Système d'ouverture
■ Opening system
■ Öffnungssystem



■ **Optional** consigliato:
Art. 922 fodera in Mytex
■ **Option** conseillée:
Art. 922 Housse en Mytex
■ **Recommended option:**
Art. 922 Mytex cover
■ **Empfohlene Option:**
Art. 922 Schutzhülle aus Mytex



■ **Optional:** base con ruote
■ **Option:** pied avec roulettes
■ **Option:** base with wheels
■ **Option:** Fuß mit Räder



■ **Opzione:** Art. 353 base da interrare
■ **Option:** Art. 353 pied à enterrer
■ **Option:** Art. 353 in-ground base
■ **Option:** Art. 353 Sockel



■ Base a T
■ Pied en T
■ T-shaped base
■ T-form Fuß

Trend wood **Ombrellone laterale retrattile effetto legno**

CARATTERISTICHE TECNICHE

TESSUTO: PolyMa poliestere gr 210 mq, idrorepellente, antimuffa, protezione UV 50+, resistenza colori 6+.
TexMa Olefin gr 190 mq, tinto in pasta, idrorepellente, antimuffa, protezione UV 50+, resistenza colori 7. Il tessuto TexMa può essere usato per alcuni colori speciali. (T).

STRUTTURA: palo in alluminio mm 50x78, bacchette acciaio, maniglia d'apertura in alluminio con fermo di sicurezza, base a T con sistema di rotazione a 360°. Sistema d'apertura esclusivo Maffei senza corde e manovelle. La base può essere messa davanti o dietro al palo e può essere dotata di ruote.

Trend wood **Parasol déporté rétractable effet bois**

CARACTÉRISTIQUES TECHNIQUES

TISSU: PolyMa polyester, gr 210 mc, hydrofuge, anti-moisissure, protection UV 50+, résistance couleurs 6+.
TexMa Olefin gr 190 mc, teinté en masse, hydrofuge, anti-moisissure, protection UV 50+, résistance couleurs 7.
Le tissu TexMa peut être utilisé pour des couleurs spéciales (T).

STRUCTURE: mât en alu 50x78 mm, baleines acier, poignée d'ouverture en alu avec fermeture de sécurité, pied en T pivotant à 360°. Système d'ouverture exclusivité Maffei sans cordes ni manivelles. Le pied peut être placé devant ou derrière le mât et peut avoir des roulettes.

Trend wood **Wood look frame folding side parasol**

TECHNICAL FEATURES

FABRIC: PolyMa polyester, gr 210 sm, water-repellent, mouldproof, UV protection 50+, colour fastness 6+.
TexMa solution dyed Olefin gr 190 sm, water-repellent, mouldproof, UV protection 50+, colour fastness 7. The fabric TexMa can be used for some special colours (T).

FRAME: Aluminium pole 50x78 mm, steel ribs, aluminium opening handle with safety stopper, T-shaped steel base, 360° rotating. The opening system without ropes nor crank is Maffei's exclusive. The base can be placed behind or in front of the pole and can have wheels.

Trend wood **Holzoptik Klappbare Ampelschirm**

TECHNISCHE EIGENSCHAFTEN

STOFF: PolyMa Polyester, gr 210 qm, Wasserabstoßend imprägniert, Verrottungsfest, UV Schutz 50+, Lichechtheit 6+.
TexMa Olefin gr 190 qm spindüsengefärbted, Wasserabstoßend imprägniert, Verrottungsfest, Uv Schutz 50+, Lichtecktheit 7.
TexMa Stoff kann für besonders Farben benutzen sein (T)

GESTELL: Stock aus Aluminium 50x78 mm, Aluminium Griff mit Sicherheit, T-Fuß aus Stahl um 360° drehbar. Das Öffnungssystem ohne Seilzug oder Kurbel ist Exklusivität von Maffei. Der Fuß kann vor oder hinter des Stock platziert werden und kann Räder haben.

kg Contrappeso per base: min kg 40. Occorre raddoppiare il contrappeso in caso di base con ruote.
Mattonelle escluse. **Vedere contrappesi pag. 154**

kg Contrepoids pour pied: min 40 kg. Il faut doubler le contrepoids en cas de pied avec roulettes.
Dalles non incluses. **Voir contrepoids à la page 154**

kg Counterweight for base: min 40 kg. It's necessary to double up the counterweight in case of base with wheels.
Tiles not included. **See counterweights on page 154**

kg Gegengewicht für Ständer: min 40 kg. Es ist notwendig die Gegengewicht zu verdoppeln im Falle von Fuß mit Räder.
Betonplatte nicht enthalten. **Gegengewicht Seite 154**

Colori/Couleurs/Colours/Farben Art 477Q

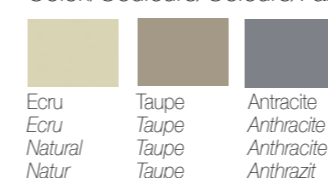

Colori/Couleurs/Colours/Farben Art 477Q-200

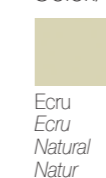

Colori su richiesta/Couleurs sur demande/Colours on demand/ Farben auf Anfrage Art 477Q

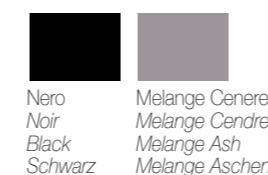

TREND ICE



Art. 467Q-200 cm 200x200/4

Art. 467Q cm 250x250/4



Art. 467Q BIANCO/BLANC/WHITE/ WEISS

TREND ICE

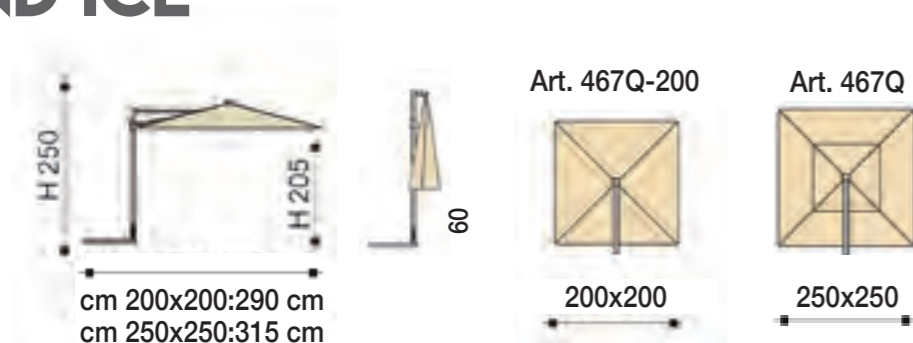

Ombrellone laterale di design **retrattile** e compatto con struttura **bianca**, apertura senza corde e/o manovelle, girevole, base a T.

Parasol déporté de design **rétractable** et compact, structure **blanche**, ouverture sans cordes ni manivelles, pivotant, pied en T.

Folding and compact aluminium side pole parasol, **white** frame, opening without handle nor crank, rotating, T-shaped base.

Klappbarer und kompakter Ampelschirm, **Weißes** Gestell, Öffnung ohne Seil oder Kurbel, drehbar, T-Fuß.



Struttura bianca
 Structure blanche
 White frame
 Weißes Gestell



Maniglia in alluminio
 Poignée en alu
 Aluminium handle
 Griff aus Aluminium

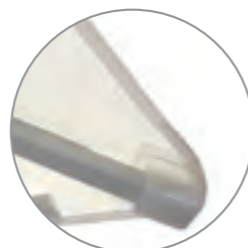

Bacchetta
 Baleine
 Rib
 Schiene



Optional consigliato:
Art. 922 fodera in Mytex
 Option conseillée:
Art. 922 Housse en Mytex
 Recommended option:
Art. 922 Mytex cover
 Empfohlene Option:
Art. 922 Schutzhülle aus Mytex



Optional: base con ruote
 Option: pied avec roulettes
 Option: base with wheels
 Option: Fuß mit Räder



Opzione: Art. 353 base da interrare
 Option: Art. 353 pied à enterrer
 Option: Art. 353 in-ground base
 Option: Art. 353 Sockel



Base a T
 Pied en T
 T-shaped base
 T-form Fuß

Trend ice Ombrellone laterale retrattile bianco

CARATTERISTICHE TECNICHE

TESSUTO: PolyMa poliestere gr 210 mq, idrorepellente, antimuffa, protezione UV 50+, resistenza colori 6+.
TexMa Olefin gr 190 mq, tinto in pasta, idrorepellente, antimuffa, protezione UV 50+, resistenza colori 7. Il tessuto TexMa può essere usato per alcuni colori speciali. (T).

STRUTTURA: palo in alluminio mm 50x78, bacchette acciaio, maniglia d'apertura in alluminio con fermo di sicurezza, base a T con sistema di rotazione a 360°. Sistema d'apertura esclusivo Maffei senza corde e manovelle. La base può essere messa davanti o dietro al palo e può essere dotata di ruote.

Trend ice Parasol déporté rétractable blanc

CARACTÉRISTIQUES TECHNIQUES

TISSU: PolyMa polyester, gr 210 mc, hydrofuge, anti-moisissure, protection UV 50+, résistance couleurs 6+.
TexMa Olefin gr 190 mc, teinté en masse, hydrofuge, anti-moisissure, protection UV 50+, résistance couleurs 7.
Le tissu TexMa peut être utilisé pour des couleurs spéciales (T).

STRUCTURE: mât en alu 50x78 mm, baleines acier, poignée d'ouverture en alu avec fermeture de sécurité, pied en T pivotant à 360°. Système d'ouverture exclusivité Maffei sans cordes ni manivelles. Le pied peut être placé devant ou derrière le mât et peut avoir des roulettes.

Trend ice White frame folding side parasol

TECHNICAL FEATURES

FABRIC: PolyMa polyester, gr 210 sm, water-repellent, mouldproof, UV protection 50+, colour fastness 6+.
TexMa solution dyed Olefin gr 190 sm, water-repellent, mouldproof, UV protection 50+, colour fastness 7. The fabric TexMa can be used for some special colours (T).

FRAME: Aluminium pole 50x78 mm, steel ribs, aluminium opening handle with safety stopper, T-shaped steel base, 360° rotating. The opening system without ropes nor crank is Maffei's exclusive. The base can be placed behind or in front of the pole and can have wheels.

Trend ice Weißer Klappbare Ampelschirm

TECHNISCHE EIGENSCHAFTEN

STOFF: PolyMa Polyester, gr 210 qm, Wasserabstoßend imprägniert, Verrottungsfest, UV Schutz 50+, Lichechtheit 6+.
TexMa Olefin gr 190 qm spindüsengefärbt, Wasserabstoßend imprägniert, Verrottungsfest, UV Schutz 50+, Lichtechtheit 7.
TexMa Stoff kann für besonders Farben benutzen sein (T)

GESTELL: Stock aus Aluminium 50x78 mm, Aluminium Griff mit Sicherheit, T-Fuß aus Stahl um 360° drehbar. Das Öffnungssystem ohne Seilzug oder Kurbel ist Exklusivität von Maffei. Der Fuß kann vor oder hinter des Stock platziert werden und kann Räder haben.

Contrappeso per base: min kg 40. Occorre raddoppiare il contrappeso in caso di base con ruote.
Mattonelle escluse. **Vedere contrappesi pag. 154**

Contrepoids pour pied: min 40 kg. Il faut doubler le contrepoids en cas de pied avec roulettes.
Dalles non incluses. **Voir contrepoids à la page 154**

Counterweight for base: min 40 kg. It's necessary to double up the counterweight in case of base with wheels.
Tiles not included. **See counterweights on page 154**

Gegengewicht für Ständer: min 40 kg. Es ist notwendig die Gegengewicht zu verdoppeln im Falle von Fuß mit Räder.
Betonplatte nicht enthalten. **Gegengewicht Seite 154**

Colori/Couleurs/Colours/Farben Art 467Q

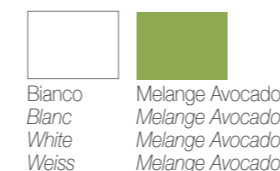

Bianco
Blanc
White
Weiss

Melange Avocado
Melange Avocado
Melange Avocado
Melange Avocado

Colori/Couleurs/Colours/Farben Art 467Q-200



Bianco
Blanc
White
Weiss

BORDER



Art. 47R cm 300x200/4



Art. 47R ECRU/NATURAL/NATUR

BORDER

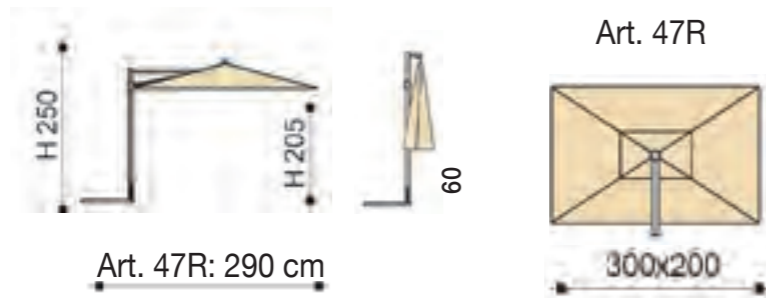

-  Ombrellone laterale di design **retrattile** e compatto con struttura colore **grafite**, apertura senza corde e/o manovelle, girevole, base a T. Design esclusivo **Border** by Maffei su tessuto Dralon
-  Parasol déporté de design **rétractable** et compact, structure couleur **graphite**, ouverture sans cordes et/ou manivelles, pivotant, pied en T. Design exclusif **Border** by Maffei sur tissu Dralon
-  **Folding** and compact aluminium side pole parasol, **graphite** colour frame, opening without handle nor crank, rotating, T-shaped base. Exclusive Design **Border** by Maffei on Dralon fabric
-  **Klappbarer** und kompakter Ampelschirm, **Graphitfarbenen** Gestell, Öffnung ohne Seil oder Kurbel, drehbar, T-Fuß. Exclusives Design **Border** by Maffei auf Dralon Stoff

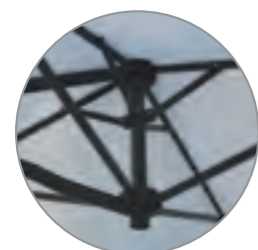





-  Struttura colore grafite
-  Structure couleur graphite
-  Graphite colour frame
-  Gestell Farbe Graphit







-  Manopola alluminio
-  Poignée alu
-  Aluminium handle
-  Griff aus Aluminium

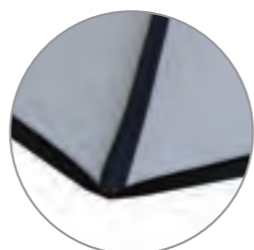

-  Sistema di rotazione
-  Système pivotant
-  Rotating system
-  Rotationssystem







-  Cuciture in tinta con il telaio
-  Coutures en teinte avec la structure
-  Seams matching the frame
-  Nähte passend zum Gestell







-  **Optional** consigliato: Art. 922 fodera in Mytex
-  **Option** conseillée: Art. 922 Housse en Mytex
-  **Recommended option:** Art. 922 Mytex cover
-  **Empfohlene Option:** Art. 922 Schutzhülle aus Mytex







-  **Opzione:** Art. 353 base da interrare
-  **Option:** Art. 353 pied à enterrer
-  **Option:** Art. 353 in-ground base
-  **Option:** Art. 353 Sockel



-  **Optional:** base con ruote
-  **Option:** pied avec roulettes
-  **Option:** base with wheels
-  **Option:** Fuß mit Räder



-  Base a T
-  Pied en T
-  T-shaped base
-  T-form Fuß

Border Ombrellone laterale retrattile

CARATTERISTICHE TECNICHE

TESSUTO: Dralon Acrilico 100% gr 190 mq, finitura Sun, protezione UV 20/50+ (dipende dal colore), resistenza colori 5/6. Il design Border presenta le cuciture con bordino in tinta con il telaio.

STRUTTURA: palo in alluminio mm 50x78, struttura colore grafite, bacchette acciaio, maniglia d'apertura in alluminio con fermo di sicurezza, base a T con sistema di rotazione a 360°. Sistema d'apertura esclusivo Maffei senza corde e manovelle. La base può essere messa davanti o dietro al palo e può essere dotata di ruote.

Border Parasol déporté rétractable

CARACTÉRISTIQUES TECHNIQUES

TISSU: Dralon Acrylique 100%, gr 190mc, finition Sun, protection UV 20/50+ (selon couleur), résistance couleurs 5/6 (selon couleur). Le design Border présente les coutures avec bord en teinte avec la structure.

STRUCTURE: mâts en alu 50x78 mm, structure couleur graphite, baleines acier, poignée d'ouverture en alu avec fermeture de sécurité, pied en T pivotant à 360°. Système d'ouverture exclusivité Maffei sans cordes ni manivelles. Le pied peut être placé devant ou derrière le mât et peut avoir des roulettes.

Border Folding side pole parasol

TECHNICAL FEATURES

FABRIC: Dralon Acrylic 100% gr 190 sm, Sun finish, mouldproof, UV protection 20/50+ (depending on colour), colour fastness 5/6 (depending on colour). The Border design presents seams matching the frame.

FRAME: aluminium pole 50x78 mm graphite colour frame, steel ribs, aluminium opening handle with safety stopper, T-shaped steel base, 360° rotating. The opening system without ropes nor crank is Maffei's exclusivity. The base can be placed behind or in front of the pole and can have wheels.

Border Klappbarer Ampelschirm

TECHNISCHE EIGENSCHAFTEN

STOFF: Dralon Acryl 100%, gr 190 qm Sun beschichtet, UV Schutz 20/50+ (nach Farbe), Lichtechtheit 5/6 (nach Farbe). Das Border Design ist mit eine Paspelhaht zur Gestell passenden.

GESTELL: Stock aus Aluminium, Gestell Graphitfarbe 50x78 mm, Stahlstreben, Aluminium Griff mit Sicherheit, T-Fuß aus Stahl um 360° drehbar. Das Öffnungssystem ohne Seilzug oder Kurbel ist Exklusivität von Maffei. Der Fuß kann vor oder hinter des Stock platziert werden und kann Räder haben.

 Contrappeso per base: min kg 40. Occorre raddoppiare il contrappeso in caso di base con ruote. Mattonelle escluse. **Vedere contrappesi pag. 154**

 Contrepoids pour pied: min 40 kg. Il faut doubler le contrepoids en cas de pied avec roulettes. Dalles non incluses. **Voir contrepoids à la page 154**

 Counterweight for base: min 40 kg. It's necessary to double up the counterweight in case of base with wheels. Tiles not included. **See counterweights on page 154**

 Gegengewicht für Ständer: min 40 kg. Es ist notwendig die Gegengewicht zu verdoppeln im Falle von Fuß mit Räder. Betonplatte nicht enthalten. **Gegengewicht Seite 154**

Colori/Couleurs/Colours/Farben

			
Bianco	Ecru	Taupe	Agua de Mar
Blanc	Ecru	Taupe	Agua de Mar
White	Natural	Taupe	Agua de Mar
Weiss	Natur	Taupe	Agua de Mar

PARROT



Art. P3 cm 135/6-D 270



PARROT

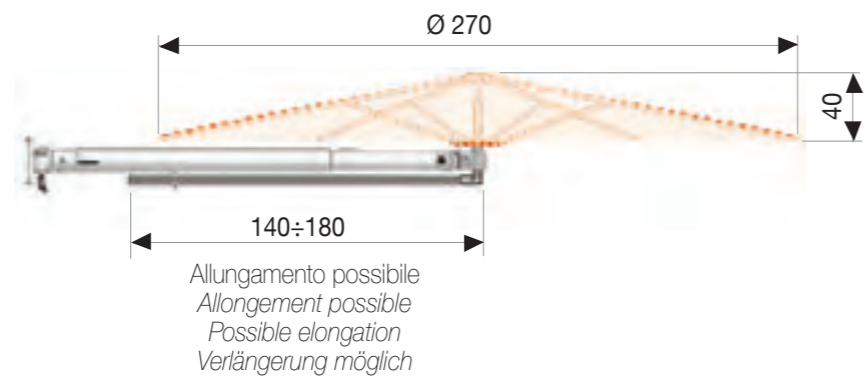

IT Ombrellone da muro, permette di utilizzare con la massima libertà lo spazio sottostante. L'ombrellone Parrot è totalmente regolabile in quanto girevole, inclinabile e dotato di braccio estensibile da cm 140 a cm 180.

FR Parasol mural, notre modèle Parrot permet d'utiliser sans limitations l'espace au dessous. Il est totalement réglable, dès qu'il peut pivoter, le bras est extensible de 140 à 180 cm et inclinable.

EN Our wall parasol Parrot allows to fully enjoy the space underneath, as it's completely rotating, tiltable and extendable thanks to the telescopic horizontal arm.

DE Unserer Wandsonnenschirm Parrot ermöglicht den Raum darunter mit maximaler Freiheit zu nutzen. Der Parrot ist voll verstellbar, da kann es drehen, neigen und der Arm zu cm 180 strecken.



IT Braccio estensibile in alluminio
FR Bras extensible en alu
EN Aluminium telescopic arm
DE Teleskop arm aus Aluminium



IT Manopola alluminio
FR Manopola aluminium
EN Aluminium tilt and ribs
DE Aluminium Streben und Knicker

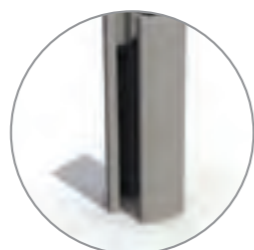

IT Aggancio a muro
FR Crochet pour le mur
EN Wall bracket
DE Wandhaken

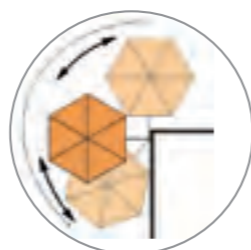

IT Rotazione sull'angolo del muro
FR Rotation sur le coin du mur
EN Rotation on the corner of the wall
DE Drehung an der Ecke der Wand



IT **Optional** consigliato:
Art. 921/P3 fodera Mytex per Parrot
FR **Option** conseillée:
Art. 921/P3 housse Mytex pour Parrot
EN **Recommended option:**
Art. 921/P3 Mytex cover for Parrot
DE **Empfohlene Option:**
Art. 921/P3 Mytex Schutzhülle für Parrot



IT 1 - Chiuso
FR 1 - Fermé
EN 1 - Closed
DE 1 - Geschlossen



IT 2 - Apertura fase 1
FR 2 - Ouverture pas 1
EN 2 - Opening step 1
DE 2 - Öffnung Schnitt 1



IT 3 - Apertura fase 2
FR 3 - Ouverture pas 2
EN 3 - Opening step 2
DE 3 - Öffnung Schnitt 2

Parrot Ombrellone da muro in alluminio

CARATTERISTICHE TECNICHE

TESSUTO: PolyMa poliestere gr 210 mq, idrorepellente, antimuffa, protezione UV 50+, resistenza colori 6+.

STRUTTURA: Braccio alluminio estensibile cm 140-180, palo centrale mm 30, bacchette, inclinazione, agganci per muro in alluminio.

Parrot Parasol mural en aluminium

CARACTÉRISTIQUES TECHNIQUES

TISSU: PolyMa Polyester, gr 210 mc, hydrofuge, anti-moisissure, protection UV 50+, résistance couleurs 6+.

STRUCTURE: bras extensible 140-180 cm en alu, mât central 30 mm, baleines, inclinaison et crochets pour mur en alu.

Parrot Aluminium wall parasol

TECHNICAL FEATURES

FABRIC: PolyMa Polyester gr 210 sm, water-repellent, mouldproof, UV protection 50+, colour fastness 6+.

FRAME: aluminium telescopic arm 140-180 cm, aluminium central pole 30 mm, ribs, tilt system and wall brackets.

Parrot Wandschirm aus Aluminium

TECHNISCHE EIGENSCHAFTEN

STOFF: PolyMa Polyester gr 210 qm, Wasserabstoßend imprägniert, Verrottungsfest, UV Schutz 50+, Lichtechtheit 6+.

GESTELL: Teleskoparm aus Aluminium 140-180 cm, zentraler Stock 30 mm, Streben, Knickersystem und Wandhaken aus Aluminium.

Colori/Couleurs/Colours/Farben

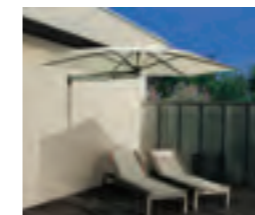

Ecu
Ecu
Natural
Natur

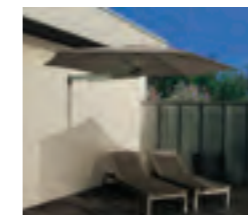

Taupe
Taupe
Taupe
Taupe

Colori su richiesta/Couleurs sur demande/Colours on demand/Farben auf Anfrage



Bianco
Blanc
White
Weiss



Giallo
Jaune
Yellow
Gelb



Arancio
Orange
Orange
Orange

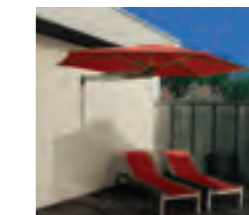

Rosso
Rouge
Red
Rot



Verde
Vert
Green
Grün

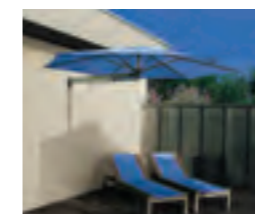

Azzurro
Azur
Azur
Hellblau

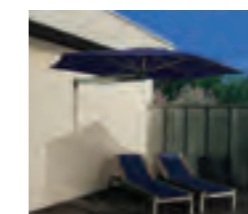

Blu
Bleu
Blue
Blau

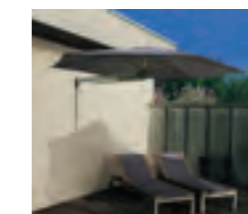

Antracite
Anthracite
Anthracite
Anthrazit

OMBRELLONI GRANDI

La collezione Maffei soddisfa ogni esigenza di spazio, coprendo con eleganza anche grandi superfici.

GRANDS PARASOLS

La collection Maffei répond à toutes les exigences de votre extérieur, en couvrant avec élégance même les grandes surfaces.

LARGE PARASOLS

Maffei's parasols are suitable to different types of space, they elegantly cover wide surfaces too.

GROB-MARKTSCHIRME

Die Kollektion von Maffei passt zu jedem Platzbedarf und beschattet mit hoher Eleganz auch große Flächen.



FIBRASOL SILVER



Art. 175Q cm 300x300/8

Art. 176R cm 300x400/8



FIBRASOL SILVER

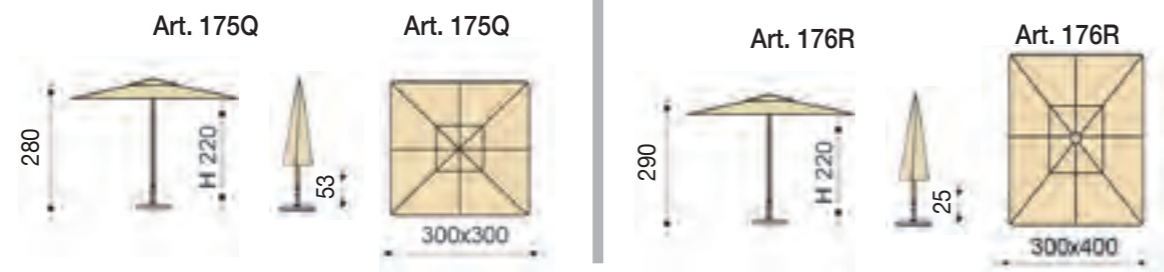

Ombrellone con struttura in fibra di vetro, colore silver. La struttura in fibra di vetro conferisce resistenza, elasticità e durata superiori a quelle offerte da legno o metallo; la fibra di vetro è un materiale composito in grado di assorbire le sollecitazioni improvvise.

Parasol avec structure en fibre de verre, couleur alu. La structure en fibre de verre donne résistance, élasticité et durabilité supérieures au bois ou métal; la fibre de verre est un matériel composite capable d'absorber la pression soudaine du vent.

Parasol with fiberglass frame, silver colour. Fiberglass gives much more strength, elasticity and endurance than wood or metal; fiberglass is a composite material able to absorb sudden stress.

Sonnenschirm mit Gestell aus Glasfaser, Farbe Silber. Das Gestell aus Glasfaser, hat hoher Festigkeit, Flexibilität und Dauer als Holz oder Metall; Glasfaser ist a Verbundmaterial und kann Plötzliche Kräfteinwirkungen absorbieren.

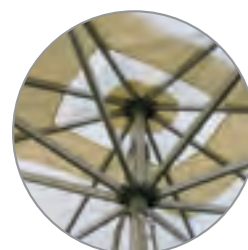

■ Bacchette in fibra di vetro intercambiabili
■ Baleines en fibre de verre échangeables
■ Exchangeable fiberglass ribs
■ Austauschbare Glasfaser Streben



■ Accessori in resina rinforzata
■ Accessoires en résine renforcée
■ Reinforced resin hubs
■ Zubehör aus verstärktes Harz



■ Viteria inox
■ Visserie inox
■ Stainless Steel hardware
■ Edehstahl Schrauben



■ Doppia carrucola
■ Double poulie
■ Double pulley
■ Doppeln Seilzug

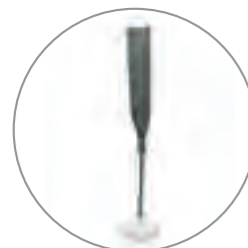

■ **Optional** consigliato:
Art. 922 fodera in Mytex
■ **Option** conseillée:
Art. 922 Housse en Mytex
■ **Recommended option:**
Art. 922 Mytex cover
■ **Empfohlene Option:**
Art. 922 Schutzhülle aus Mytex

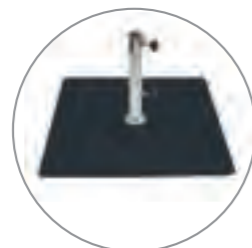

■ **Optional:** Base in metallo calpestabile
■ **Option:** Plaque métallique
■ **Option:** Metal base
■ **Option:** Metallständer

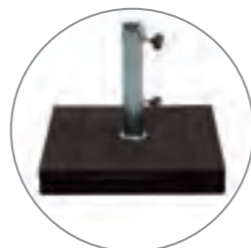

■ **Optional:** Base in cemento effetto legno
■ **Option:** Pied en béton finition bois
■ **Option:** Wooden effect concrete base
■ **Option:** Holzoptik Betonplatteständer



■ **Optional:** Base in graniglia
■ **Option:** Pied en grès
■ **Option:** Grit base
■ **Option:** Betonständer

■ Fibrasol Silver Ombrellone con struttura in fibra di vetro

CARATTERISTICHE TECNICHE

TESSUTO: PolyMa poliestere gr 210 mq, idrorepellente, antimuffa, protezione UV 50+, resistenza colori 6+.
TexMa Olefin gr 190 mq, tinto in pasta, idrorepellente, antimuffa, protezione UV 50+, resistenza colori 7.
Il tessuto TexMa può essere usato per alcuni colori speciali. (T).

STRUTTURA: Palo mm 48 in **fibra di vetro**, bacchette sostituibili in fibra di vetro, struttura colore silver, viteria inox, doppia carrucola.

■ Fibrasol Silver Parasol avec structure en fibre de verre

CARACTÉRISTIQUES TECHNIQUES

TISSU: PolyMa polyester, gr 210 mc, hydrofuge, anti-moisissure, protection UV 50+, résistance couleurs 6+.
TexMa Olefin gr 190 mc, teinté en masse, hydrofuge, anti-moisissure, protection UV 50+, résistance couleurs 7.
Le tissu TexMa peut être utilisé pour des couleurs spéciales (T).

STRUCTURE: mât en **fibre de verre** 48 mm, baleines échangeables en fibre de verre, structure couleur silver, visserie inox, double poulie.

🇬🇧 Fibrasol Silver Parasol with fiberglass frame

TECHNICAL FEATURES

FABRIC: PolyMa polyester, gr 210 sm, water-repellent, mouldproof, UV protection 50+, colour fastness 6+.
TexMa solution dyed Olefin gr 190 sm, water-repellent, mouldproof, UV protection 50+, colour fastness 7.
The fabric TexMa can be used for some special colours (T).

FRAME: Fiberglass pole 48 mm, exchangeable **fiberglass** ribs, silver colour frame, s/s hardware, double pulley..

🇩🇪 Fibrasol Silver Sonnenschirm mit Gestell aus Glasfaser

TECHNISCHE EIGENSCHAFTEN

STOFF: PolyMa Polyester, gr 210 qm, Wasserabstoßend imprägniert, Verrottungsfest, UV Schutz 50+, Lichteinheit 6+.
TexMa Olefin gr 190 qm spindüsengefärbted, Wasserabstoßend imprägniert, Verrottungsfest, UV Schutz 50+, Lichteinheit 7.
Der Stoff TexMa kann für etwa besonders Farben benutzen sein.

GESTELL: Stock 48 mm aus **Glasfaser**, austauschbare Streben aus Glasfaser, Gestell Silber Farbe, Edehstahl Schrauben, mit doppel Seilzug.

Le misure indicate non includono la base. Con base: + ca.5/10 cm.

Les mesures indiquées ne comprennent pas le pied. Avec pied: + ca.5/10 cm

These sizes don't include the base height. With base: + ca.5/10 cm

Diese Maßnahmen umfassen nicht den Fuß. Mit Fuß: + ca.5/10 cm

kg Peso per base: min kg 35. Con peso maggiore avrete più stabilità e sicurezza. **Vedere basi pag. 154**

kg Poids pour pied: min 35 kg. Avec plus de poids il y aura une majeure stabilité et sécurité. **Voir pieds à la page 154**

kg Weight for base: min 35 kg. With higher weight, there are better stability and safety. **See bases on page 154**

kg Gewicht für Ständer: min 35 kg. Mit höher Gewicht, es gibt besser stabilität und Sicherheit. **Ständer Seite 154**

Colori/Couleurs/Colours/Farben



Ecrú
Ecrú
Natural
Natur
Taupe
Taupe
Taupe
Taupe

Colori su richiesta/Couleurs sur demande/Colours on demand/Farben auf Anfrage



Bianco
Blanc
White
Weiss
Giallo
Jaune
Yellow
Gelb
Verde
Vert
Green
Grün
Arancio
Orange
Orange
Orange
Rosso
Rouge
Red
Rot
Blu
Bleu
Blue
Blau
Antracite
Anthracite
Anthracit
Anthraxit
Nero
Noir
Black
Schwarz

FIBRASOL WOOD



Art. 155Q cm 300x300/8

Art. 156R cm 300x400/8



Art. 155Q TAUPE

FIBRASOL WOOD

Art. 155Q

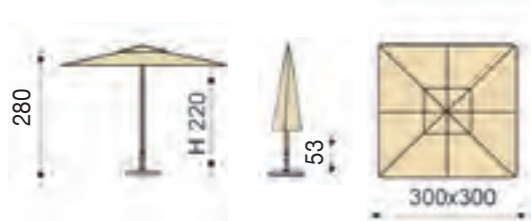

Art. 156R

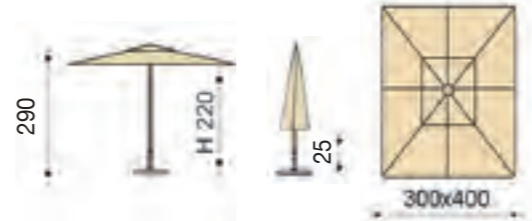

Ombrellone con struttura in fibra di vetro, colore teak. La struttura in fibra di vetro conferisce resistenza, elasticità e durata superiori a quelle offerte da legno o metallo; la fibra di vetro è un materiale composito in grado di assorbire le sollecitazioni improvvise.

Parasol avec structure en fibre de verre, couleur teck. La structure en fibre de verre donne résistance, élasticité et durabilité supérieures au bois ou métal; la fibre de verre est un matériel composite capable d'absorber la pression soudaine du vent.

Parasol with fiberglass frame, teak colour. Fiberglass gives much more strength, elasticity and endurance than wood or metal; the fiberglass is a composite material able to absorb sudden stress.

Sonnenschirm mit Gestell aus Glasfaser, Farbe Teak. Das Gestell aus Glasfaser, hat hoher Festigkeit, Flexibilität und Dauer als Holz oder Metall; Glasfaser ist a Verbundmaterial und kann Plötzliche Kräfteinwirkungen absorbieren.



- Bacchette in fibra di vetro intercambiabili
- Baleines en fibre de verre échangeables
- Exchangeable fiberglass ribs
- Austauschbare Glasfaser Streben



- Accessori in resina rinforzata
- Accessoires en résine renforcée
- Reinforced resin hubs
- Zubehöre aus verstärktes Harz



- Viteria inox
- Visserie inox
- Stainless Steel hardware
- Edehstahl Schrauben



- Doppia carrucola
- Double poulie
- Double pulley
- Doppeln Seilzug



- Optional** consigliato:
Art. 922 fodera in Mytex
- Option** conseillée:
Art. 922 Housse en Mytex
- Recommended option:**
Art. 922 Mytex cover
- Empfohlene Option:**
Art. 922 Schutzhülle aus Mytex

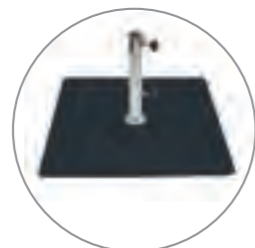

- Optional:** Base in metallo calpestabile
- Option:** Plaque métallique
- Option:** Metal base
- Option:** Metallständer

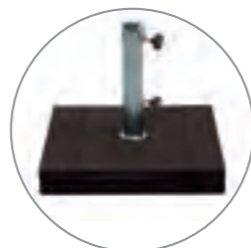

- Optional:** Base in cemento effetto legno
- Option:** Pied en béton finition bois
- Option:** Wooden effect concrete base
- Option:** Holzoptik Betonplatteständer



- Optional:** Base in graniglia
- Option:** Pied en grès
- Option:** Grit base
- Option:** Betonständer

Fibrasol Wood Ombrellone con struttura in fibra di vetro

CARATTERISTICHE TECNICHE

TESSUTO: PolyMa poliestere gr 210 mq, idrorepellente, antimuffa, protezione UV 50+, resistenza colori 6+.
TexMa Olefin gr 190 mq, tinto in pasta, idrorepellente, antimuffa, protezione UV 50+, resistenza colori 7.
Il tessuto TexMa può essere usato per alcuni colori speciali. (T).

STRUTTURA: palo mm 48 in **fibra di vetro**, bacchette intercambiabili in fibra di vetro, struttura colore teak, viteria inox, doppia carrucola.

Fibrasol Wood Parasol avec structure en fibre de verre

CARACTÉRISTIQUES TECHNIQUES

TISSU: PolyMa polyester, gr 210 mc, hydrofuge, anti-moisissure, protection UV 50+, résistance couleurs 6+.
TexMa Olefin gr 190 mc, teinté en masse, hydrofuge, anti-moisissure, protection UV 50+, résistance couleurs 7.
Le tissu TexMa peut être utilisé pour des couleurs spéciales (T).

STRUCTURE: mât en **fibre de verre** 48 mm, baleines échangeables en fibre de verre, structure couleur teck, visserie inox, double poulie.

Fibrasol Wood Parasol with fiberglass frame

TECHNICAL FEATURES

TISSU: PolyMa polyester, gr 210 mc, hydrofuge, anti-moisissure, protection UV 50+, résistance couleurs 6+.
TexMa Olefin gr 190 mc, teinté en masse, hydrofuge, anti-moisissure, protection UV 50+, résistance couleurs 7.
Le tissu TexMa peut être utilisé pour des couleurs spéciales (T).

STRUCTURE: mât en **fibre de verre** 48 mm, baleines échangeables en fibre de verre, structure couleur teck, visserie inox, double poulie.

Fibrasol Wood Sonnenschirm mit Gestell aus Glasfaser

TECHNISCHE EIGENSCHAFTEN

STOFF: PolyMa Polyester, gr 210 qm, Wasserabstoßend imprägniert, Verrottungsfest, UV Schutz 50+, Lichtehtheit 6+.
TexMa Olefin gr 190 qm spindüsengefärbted, Wasserabstoßend imprägniert, Verrottungsfest, Uv Schutz 50+, Lichtehtheit 7.
Der Stoff TexMa kann für etwa besonders Farben benutzen sein.

GESTELL: Stock 48 mm aus **Glasfaser**, austauschbare Streben aus Glasfaser, Gestell Teak Farbe, Edehstahl Schrauben, mit doppeln Seilzug.

Le misure indicate non includono la base. Con base: + ca.5/10 cm.

Les mesures indiquées ne comprennent pas le pied. Avec pied: + ca.5/10 cm

These sizes don't include the base height. With base: + ca.5/10 cm

Diese Maßnahmen umfassen nicht den Fuß. Mit Fuß: + ca.5/10 cm

kg Peso per base: min kg 35. Con peso maggiore avrete più stabilità e sicurezza. **Vedere basi pag. 154**

kg Poids pour pied: min 35 kg. Avec plus de poids il y aura une majeure stabilité et sécurité. **Voir pieds à la page 154**

kg Weight for base: min 35 kg. With higher weight, there are better stability and safety. **See bases on page 154**

kg Gewicht für Ständer: min 35 kg. Mit höher Gewicht, es gibt besser stabilität und Sicherheit. **Ständer Seite 154**

Colori/Couleurs/Colours/Farben



Ecru
Ecrú
Natural
Natur

Taupe
Taupe
Taupe
Taupe

Colori su richiesta/Couleurs sur demande/Colours on demand/Farben auf Anfrage

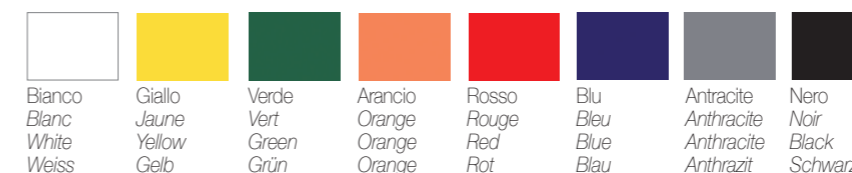

Bianco
Blanc
White
Weiss

Giallo
Jaune
Yellow
Gelb

Verde
Vert
Green
Grün

Arancio
Orange
Orange
Orange

Rosso
Rouge
Red
Rot

Blu
Bleu
Blue
Blau

Antracite
Anthracite
Anthracite
Anthrazit

Nero
Noir
Black
Schwarz

GREENER

NOVITÀ
NOUVEAUTE
NEW
NEUHEIT
2025



Art. 161 cm 135/8-D270/8



Art. 161 ANTRACITE/ANTHRACITE/ANTHRAZIT

GREENER



TESSUTO RICICLATO

TISSU RECYCLÉ

RECYCLED FABRIC

RECYCELTER STOFF

TELAIO LEGNO NATURALE

STRUCTURE BOIS NATUREL

NATURAL WOOD FRAME

NATÜRLICH HOLZSTRUKTUR

Greener è la serie di ombrelloni Maffei a **basso impatto ambientale**. Questo risultato viene ottenuto utilizzando il **tessuto Acrilico tinto in pasta riciclato Raytent** (prodotto certificato Remade) ed una **struttura costruita con legno di origine europea**. A seconda delle versioni, viene anche eliminato (o limitato al massimo) l'uso della plastica. La qualità costruttiva permette sia un uso privato che professionale.

Greener est la gamme de parasols Maffei à **faible impact environnemental**. Ce résultat est obtenu en utilisant le **tissu Acrylique teint dans la masse recyclé Raytent** (produit certifié Remade) et une **structure fabriquée avec du bois d'origine européenne**. Selon les versions, l'utilisation du plastique est également réduite au minimum, voire éliminée. La qualité des matériaux utilisés permet à la fois une utilisation privée et professionnelle.

Greener is the line of Maffei umbrellas with **low environmental impact**. This result is achieved by using **recycled Raytent Acrylic fabric** (a certified product) and a **structure built with European-origin wood**. Depending on the version, the use of plastic is also eliminated or strongly minimized. The quality of the materials used allows both private and professional use.

Greener ist die Serie von Maffei-Sonnenschirmen mit weniger **Umweltbelastung**. Dieses Ergebnis wird durch die Verwendung von **recyceltem Raytent Acrylstoff** (ein zertifiziertes Produkt) und einer **Struktur aus europäischem Holz erreicht**. Je nach Ausführung wird auch der Einsatz von Plastik stark reduziert oder ganz vermieden. Die Qualität der verwendeten Materialien ermöglicht sowohl eine private als auch eine professionelle Nutzung.



- Bacchette legno intercambiabili
- Baleines en bois échangeables
- Exchangeable wooden ribs
- Austauschbare Holzstreben



- Accessori in legno naturale
- Accessoires en bois naturel
- Natural wooden hubs
- Zubehöre aus Naturholz

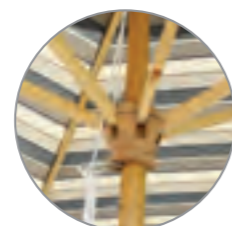

- Palo in legno naturale
- Mât en bois naturel
- Natural wood pole
- Naturholz stock



- Carrucola
- Poulie
- Pulley
- Seilzug

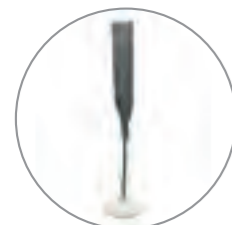

- Optional** consigliato:
Art. 922 fodera in Mytex
- Option** conseillée:
Art. 922 Housse en Mytex
- Recommended option**:
Art. 922 Mytex cover
- Empfohlene Option**:
Art. 922 Schutzhülle aus Mytex



- Optional**: Base in metallo calpestable
- Option**: Plaque métallique
- Option**: Metal base
- Option**: Metallständer

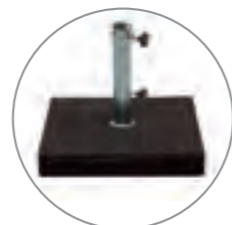

- Optional**: Base in cemento effetto legno
- Option**: Pied en béton finition bois
- Option**: Wooden effect concrete base
- Option**: Holzoptik Betonplatteständer



- Optional**: Base in graniglia
- Option**: Pied en grès
- Option**: Grit base
- Option**: Betonständer

Greener Ombrellone ecologico con struttura in legno

CARATTERISTICHE TECNICHE

TESSUTO: **Acrilico tinto in pasta riciclato** Raytent, idrorepellente, antimuffa, protezione UV50+, colori garantiti 5 anni. Il tessuto Raytent viene prodotto con gli sfridi e gli scarti di tessuto derivanti dalla produzione di ombrelloni e tende. Attraverso un processo sostenibile ed efficiente, viene ottenuto un tessuto che ha le stesse prestazioni del tessuto nuovo, ma risparmiando energia ed evitando inquinamento.

STRUTTURA: palo mm 48, bacchette intercambiabili ed accessori in legno colore naturale, viteria e carrucole zincate, legno di origine europea per bacchette ed accessori (su richiesta per il palo), uso di plastiche assente o molto limitato.

Greener Parasol écologique avec structure en bois

CARACTÉRISTIQUES TECHNIQUES

TISSU: **Acrylique teinté dans la masse recyclé** Raytent, hydrofuge, anti-moisissure, protection UV50+, couleurs garanties 5 ans. Le tissu Raytent est fabriqué à partir de chutes et de déchets de tissu issus de la production de parasols et de stores. Grâce à un processus durable et efficace, on obtient un tissu qui présente les mêmes performances que le tissu neuf, tout en économisant de l'énergie et en évitant la pollution.

STRUCTURE: mât de 48 mm, baleines interchangeable et accessoires en bois couleur naturelle, visserie et poulies galvanisées, bois d'origine européenne pour les baleines et accessoires (sur demande pour le mât), utilisation de plastiques absente ou très limitée.

Greener Ecological parasol with wooden frame

TECHNICAL FEATURES

FABRIC: **Recycled solution dyed acrylic** Raytent, water-repellent, anti-mold, UV50+ protection, colors guaranteed for 5 years. The Raytent fabric is made from scraps and waste fabric from the production of umbrellas and awnings. Through a sustainable and efficient process, a fabric is obtained that has the same performance as new fabric, while saving energy and avoiding pollution.

FRAME: 48 mm pole, interchangeable ribs and natural wood accessories, galvanized screws and pulleys, European origin wood for ribs and accessories (on request for the pole), minimal or no use of plastics

Greener Ökologischer Sonnenschirm mit Holzgestell

TECHNISCHE EIGENSCHAFTEN

STOFF: **Recycelte Spinnfärbes Acryl** Raytent, wasserabweisend, schimmelresistent, UV50+-Schutz, Farben garantiert für 5 Jahre. Der Raytent-Stoff wird aus Resten und Abfallstoffen der Produktion von Sonnenschirmen und Markisen hergestellt. Durch einen nachhaltigen und effizienten Prozess wird ein Stoff erhalten, der die gleiche Leistung wie neuer Stoff bietet und gleichzeitig Energie spart und Umweltverschmutzung vermeidet.

GESTELL: 48 mm Mast, austauschbare Schienen und Accessoires aus Naturholz, verzinkte Schrauben und Rollen, europäisches Holz für Schienen und Accessoires (auf Anfrage für den Mast), Verwendung von Kunststoffen minimal oder nicht vorhanden

Le misure indicate non includono la base. Con base: + ca.5/10 cm.

Les mesures indiquées ne comprennent pas le pied. Avec pied: + ca.5/10 cm

These sizes don't include the base height. With base: + ca.5/10 cm

Diese Maßnahmen umfassen nicht den Fuß. Mit Fuß: + ca.5/10 cm

kg Peso minimo per base: kg 30 **Vedere basi pag. 154**

kg Poids minimum pour pied: 30 kg **Voir pieds à la page 154**

kg Minimum weight for base: 30 kg **See bases on page 154**

kg Mindestgewicht pro Fuß: 30 kg **Ständer Seite 154**

Colori/Couleurs/Colours/Farben



Avena
Avoine
Oats
Hafer



Pomice
Pierre ponce
Pumice
Bimsstein



Antracite
Anthracite
Anthracite
Anthrazit



Ardesia (Rigato)
Ardoise (Rayé)
Slate (Stripes)
Schiefer (Streifen)

TIMBERS



Art. 152R cm 300x200/6

Art. 153Q cm 300x300/8

Art. 154R cm 400x300/8



Art. 153Q ECRU/NATURAL/NATUR

TIMBERS

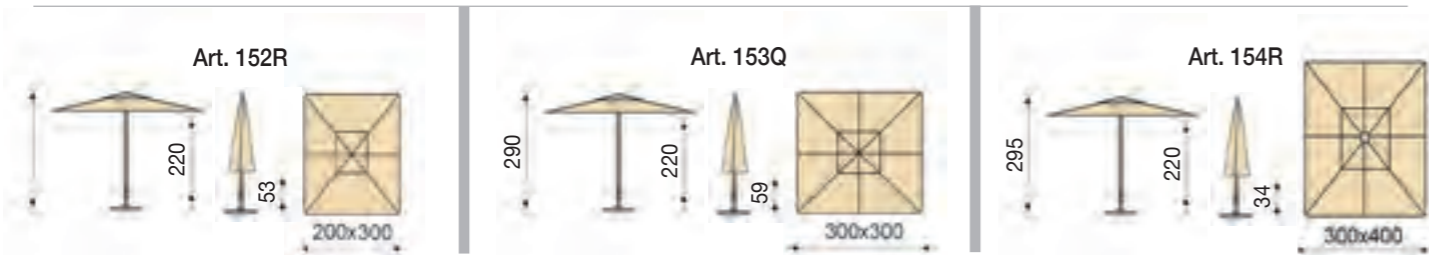

IT TIMBERS è la serie di ombrelloni in legno di Maffei. Il palo in **legno** con doppia verniciatura, le finiture interne ottonate, le stecche intercambiabili, la qualità del legno distinguono il nostro prodotto dagli altri sul mercato.

FR TIMBERS est la ligne de parasols en bois de Maffei. Le mât en **bois** avec double peinture, les finitions laitonnées, les baleines échangeables, la qualité du bois, font la différence par rapport au marché.

UK TIMBERS is Maffei's line of wooden parasols. The **wooden** pole with double transparent coating, the brass finish for hub, the exchangeable ribs and the quality of wood make this parasol unique on the market.

DE TIMBERS ist die Holz-Serie der Maffei-Produktion. Der **Holzstock** mit Doppellackierung, die Messing-Finish, die austauschbaren Holzstreben, die hoher Qualität Holz machen diesen Sonnenschirm einmalig auf dem Markt.



IT Bacchette legno intercambiabili
FR Baleines en bois échangeables
UK Exchangeable wooden ribs.
DE Austauschbare Holzstreben



IT Accessori in legno con finiture dorate
FR Accessoires en bois fini laiton
UK Wooden hubs with metal finish
DE Zubehör aus Holz mit Messingausführung.



IT Palo doppia verniciatura
FR Mât avec double peinture
UK Pole with double coating
DE Stock mit Doppellackierung



IT Carrucola
FR Poulie
UK Pulley
DE Seilzug



IT **Optional** consigliato:
Art. 922 fodera in Mytex
FR **Option** conseillée:
Art. 922 Housse en Mytex
UK **Recommended option:**
Art. 922 Mytex cover
DE **Empfohlene Option:**
Art. 922 Schutzhülle aus Mytex

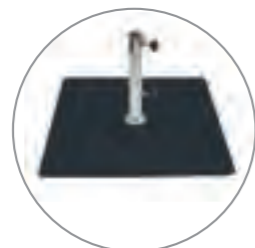

IT **Optional:** Base in metallo calpestabile
FR **Option:** Plaque métallique
UK **Option:** Metal base
DE **Option:** Metallständer

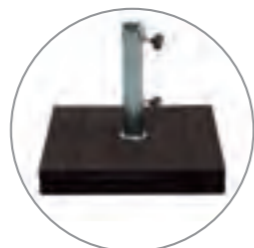

IT **Optional:** Base in cemento effetto legno
FR **Option:** Pied en béton finition bois
UK **Option:** Wooden effect concrete base
DE **Option:** Holzoptik Betonplatteständer



IT **Optional:** Base in graniglia
FR **Option:** Pied en grès
UK **Option:** Grit base
DE **Option:** Betonständer

IT Timbers Ombrellone con struttura in legno

CARATTERISTICHE TECNICHE

TESSUTO: PolyMa100% poliestere gr 210 mq, idrorepellente, antimuffa, protezione UV 50+, resistenza colori 6+.
Volante: su richiesta.

STRUTTURA: palo mm 48 in legno, bacchette intercambiabili in legno, struttura colore noce, viteria e carrucola zincate.

FR Timbers Parasol avec structure en bois

CARACTÉRISTIQUES TECHNIQUES

TISSU: PolyMa100% polyester, gr 210 mc, hydrofuge, anti-moisissure, protection UV 50+, résistance couleurs 6+.
Lambrequins: sur demande

STRUCTURE: mât en bois 48 mm, baleines échangeables en bois, structure couleur noix, visserie et poulie zinguées.

UK Timbers Parasol with wooden frame

TECHNICAL FEATURES

FABRIC: PolyMa 100% polyester, gr 210 sm, water-repellent, mouldproof, UV protection 50+, colour fastness 6+.
Valances: on demand

FRAME: Wooden pole 48 mm, exchangeable wooden ribs, nut colour frame, galvanised hardware and pulley.

DE Timbers Sonnenschirm mit Gestell aus Holz

TECHNISCHE EIGENSCHAFTEN

STOFF: PolyMa100% Polyester, gr 210 qm, Wasserabstoßend imprägniert, Verrottungsfest, UV Schutz 50+, Lichechtheit 6+.
Volants: auf Anfrage

GESTELL: Stock 48 mm aus Holz, austauschbare Streben aus Holz, Walnuss Farbe, Messing-Finish, verzinkt Schrauben und Seilzug.

Le misure indicate non includono la base. Con base: + ca.5/10 cm.

Les mesures indiquées ne comprennent pas le pied. Avec pied: + ca.5/10 cm

These sizes don't include the base height. With base: + ca.5/10 cm

Diese Maßnahmen umfassen nicht den Fuß. Mit Fuß: + ca.5/10 cm

kg Peso minimo per base: kg 30 per 300x200, kg 35 per 300x300, 400x300.
Con peso maggiore avrete più stabilità e sicurezza. **Vedere basi pag. 154**

kg Poids pour pied: 30 kg pour 300x200, 35 kg pour 300x300, 400x300.
Avec plus de poids il y aura une majeure stabilité et sécurité. **Voir pieds à la page 154**

kg Weight for base: 30 kg for 300x200, 35 kg for 300x300, 400x300.
With higher weight, there are better stability and safety. **See bases on page 154**

kg Gewicht für Ständer: 30 kg für 300x200, 35 kg für 300x300, 400x300.
Mit höher Gewicht, es gibt besser stabilität und Sicherheit. **Ständer Seite 154**

Colori/Couleurs/Colours/Farben



Ecu
Ecu
Natural
Natur

Taupe
Taupe
Taupe
Taupe

TREND TE



Art. 486Q TE cm 300x300/8



Art. 486Q TE ANTRACITE/ANTHRACITE/ANTHRAZIT

TREND TE



Art. 486

A = 103



Ombrellone con struttura in alluminio telescopica, colore grafite. Il movimento telescopico permette all'ombrellone di aprirsi e chiudersi al di sopra di tavoli o arredi sottostanti.

Parasol avec structure en aluminium télescopique, couleur graphite. Le mouvement télescopique permet au parasol de s'ouvrir et de se fermer **au-dessus** de tables ou de meubles situés en dessous.

Parasol with telescopic aluminium frame, graphite colour. The telescopic movement allows the parasol to open and close **above** tables or furniture underneath.

Sonnenschirm mit teleskopischem Aluminiumgestell, in Graphitfarbe. Die teleskopische Bewegung ermöglicht es dem Sonnenschirm, sich **über** Tischen oder Möbeln darunter zu öffnen und zu schließen.

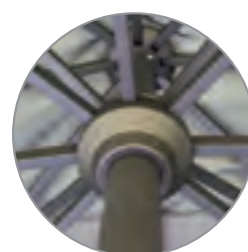

■ Struttura in alluminio
■ Structure en alu
■ Aluminium frame
■ Gestell aus Alu



■ Manopola e collano
■ Pignée et coulan
■ Handle and runner
■ Schieber

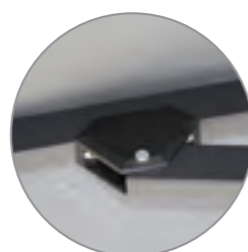

■ Bacchette
■ Baleines
■ Ribs
■ Schienen

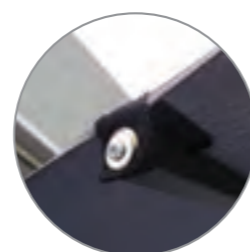

■ Aggancio tela
■ Fixation toile
■ Canvas fastner
■ Stoffbefestigung

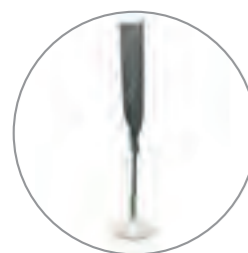

■ **Optional** consigliato:
Art. 922TE fodera in Mytex
■ **Option** conseillée:
Art. 922TE Housse en Mytex
■ **Recommended option:**
Art. 922TE Mytex cover
■ **Empfohlene Option:**
Art. 922TE Schutzhülle aus Mytex

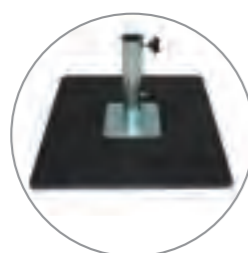

■ **Optional:** Base in metallo calpestabile
■ **Option:** Plaque métallique
■ **Option:** Metal base
■ **Option:** Metallständer



■ **Optional:** Base in graniglia
■ **Option:** Pied en grès
■ **Option:** Grit base
■ **Option:** Betonständer

Trend Te Ombrellone con struttura telescopica in alluminio

CARATTERISTICHE TECNICHE

TESSUTO: PolyMa poliestere gr 210 mq, idrorepellente, antimuffa, protezione UV 50+, resistenza colori 6+.
TexMa Olefin gr 190 mq, tinto in pasta, idrorepellente, antimuffa, protezione UV 50+, resistenza colori 7.
Il tessuto TexMa può essere usato per alcuni colori speciali. (T).

STRUTTURA: palo mm 60 in **alluminio**, bacchette alluminio, colore grafite, **apertura telescopica** manuale.

Trend Te Parasol avec structure télescopique en aluminium

CARACTÉRISTIQUES TECHNIQUES

TISSU: PolyMa polyester, gr 210 mc, hydrofuge, anti-moisissure, protection UV 50+, résistance couleurs 6+.
TexMa Olefin gr 190 mc, teinté en masse, hydrofuge, anti-moisissure, protection UV 50+, résistance couleurs 7.
Le tissu TexMa peut être utilisé pour des couleurs spéciales (T).

STRUCTURE: mât en **aluminium** de 60 mm, baleines en aluminium, couleur graphite, **ouverture télescopique** manuelle.

Trend Te Aluminium telescopic parasol

TECHNICAL FEATURES

FABRIC: PolyMa polyester, gr 210 sm, water-repellent, mouldproof, UV protection 50+, colour fastness 6+.
TexMa solution dyed Olefin gr 190 sm, water-repellent, mouldproof, UV protection 50+, colour fastness 7.
The fabric TexMa can be used for some special colours (T).

FRAME: 60 mm **aluminium** pole, aluminium ribs, graphite colour, manual **telescopic opening**.

Trend Te Teleskop Aluminium Sonnenschirm

TECHNISCHE EIGENSCHAFTEN

STOFF: PolyMa Polyester, gr 210 qm, Wasserabstoßend imprägniert, Verrottungsfest, UV Schutz 50+, Lichteinheit 6+.
TexMa Olefin gr 190 qm spindüsengefärbt, Wasserabstoßend imprägniert, Verrottungsfest, UV Schutz 50+, Lichteinheit 7.
Der Stoff TexMa kann für etwa besonders Farben benutzen sein.

GESTELL: Stock 60 mm und Schienen **Aluminium**, Graphitfarbe, **manuelle Teleskopöffnung**.

Le misure indicate non includono la base. Con base: + ca.5/10 cm.

Les mesures indiquées ne comprennent pas le pied. Avec pied: + ca.5/10 cm

These sizes don't include the base height. With base: + ca.5/10 cm

Diese Maßnahmen umfassen nicht den Fuß. Mit Fuß: + ca.5/10 cm

kg Peso per base: min kg 50. Con peso maggiore avrete più stabilità e sicurezza. **Vedere basi pag. 154**

kg Poids pour pied: min 50 kg. Avec plus de poids il y aura une majeure stabilité et sécurité. **Voir pieds à la page 154**

kg Weight for base: min 50 kg. With higher weight, there are better stability and safety. **See bases on page 154**

kg Gewicht für Ständer: min 50 kg. Mit höher Gewicht, es gibt besser stabilität und Sicherheit. **Ständer Seite 154**

Colori/Couleurs/Colours/Farben



Ecrú
Ecrú
Natural
Natur
Taupe
Taupe
Taupe
Taupe

Colori su richiesta Couleurs sur demande/Colours on demand/Farben auf Anfrage



Bianco
Blanc
White
Weiss
Rosso
Rouge
Red
Rot
Antracite
Anthracite
Anthracite
Anthrazit
Nero
Noir
Black
Schwarz

OMBRELLONI DI DESIGN

Il design esclusivo o brevettato
degli ombrelloni Maffei renderà unico
il vostro ambiente esterno

PARASOLS DESIGN

*Le design exclusif ou breveté
des parasols Maffei rendra
vos extérieurs uniques*

DESIGN PARASOLS

*Maffei's exclusive
or patented design
will make your outdoor
distinctive and unique.*

DESIGN-SONNENSCHIRME

*Die Maffei Design-Sonnenschirme
zeichnen sich durch ihr
exklusives patentiertes Design aus.
Sie ermöglichen Ihnen
einzigartiges und unverwechselbares
Ambiente, das Sie so in Ihrem
zu Hause schaffen.*



PIXEL

NOVITÀ
NOUVEAUTE
NEW
NEUHEIT
2025



Art. 501 cm 90/8-D180
Art. 505Q cm 200x200/4

Art. 503Q cm 155x155/4
Art. 507Q cm 250x250/4



Art. 505Q



Art. 501



Art. 503Q

PIXEL



Pixel è una linea di ombrelloni di design con tessuto stampato digitale, disponibile in varie forme e dimensioni per molteplici necessità. Il nostro tessuto Acrilico stampato è stato studiato in modo specifico per uso outdoor ed ha superato il test durata 1500 ore previsto dalla normativa USA.

Pixel est une ligne de parasols design avec tissu imprimé numérique, disponible en différentes formes et tailles pour répondre à divers besoins. Notre tissu acrylique imprimé a été spécialement conçu pour une utilisation en extérieur et a passé le test de durabilité de 1500 heures conforme aux normes américaines.



■ **Optional** consigliato:
Art. 922 fodera in Mytex
■ **Option** consigliée:
Art. 922 Housse en Mytex
■ **Recommended option:**
Art. 922 Mytex cover
■ **Empfohlene Option:**
Art. 922 Schutzhülle aus Mytex



■ Base a T
■ Pied en T
■ T-shaped base
■ T-form Fuß

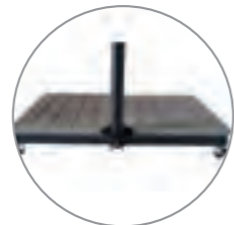

■ **Optional:** base con ruote
■ **Option:** pied avec roulettes
■ **Option:** base with wheels
■ **Option:** Fuß mit räder



■ Struttura colore grafite
■ Structure couleur graphite
■ Graphite colour frame
■ Gestell Farbe Graphit

PIXEL



Pixel is a line of design umbrellas with digitally printed fabric, available in various shapes and sizes to meet multiple needs. Our printed acrylic fabric has been specifically designed for outdoor use and has passed the 1500-hour durability test required by US standards.

Pixel ist eine Linie von Design-Sonnenschirmen mit digital bedrucktem Stoff, erhältlich in verschiedenen Formen und Größen für vielfältige Bedürfnisse. Unser bedruckter Acrylstoff wurde speziell für den Einsatz im Outdoor entwickelt und hat den 1500-Stunden-Dauerhaftigkeitstest gemäß US-Normen bestanden.



■ **Optional:** Base in graniglia
■ **Option:** Pied en grès
■ **Option:** Grit base
■ **Option:** Betonständer

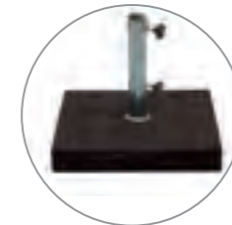

■ **Optional:** Base in cemento effetto legno
■ **Option:** Pied en béton finition bois
■ **Option:** Wooden effect concrete base
■ **Option:** Holzoptik Betonplatteständer



■ **Optional:** Base in metallo
■ **Option:** Plaque métallique
■ **Option:** Metal base
■ **Option:** Metallständer

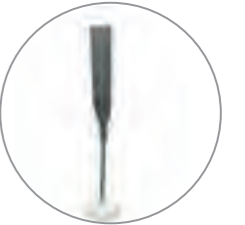

■ **Optional** consigliato:
Art. 920 per D 180 e 155x155
Art. 921 per 200x200
■ **Option** consigliée:
Art. 920 pour D 180 et 155x155
Art. 921 pour 200x200
■ **Recommended option:**
Art. 920 for D 180 and 155x155
Art. 921 for 200x200
■ **Empfohlene Option:**
Art. 920 für D 180 und 155x155
Art. 921 für 200x200

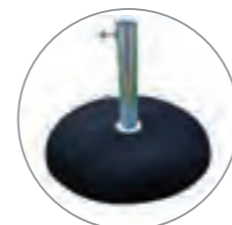

■ **Optional:** Base in cemento grafite
■ **Option:** Plaque en béton graphite
■ **Option:** Graphite concrete base
■ **Option:** Betonständer Farbe Graphit

Pixel Ombrellone di design

CARATTERISTICHE TECNICHE

TESSUTO: acrilico Dralon gr 210 mq, stampa digitale outdoor, idrorepellente, antimuffa, protezione Uv 20/50+ (dipende dal disegno), resistenza colori: 7

STRUTTURA Art. 501: pali mm 22/25 e bacchette in acciaio verniciate grafite, senza inclinazione, apertura manuale, altezza regolabile, prolungo con vite.

STRUTTURA Art. 503Q: pali mm 22/25 in acciaio e bacchette paragon verniciate grafite, snodo metallo, apertura manuale, altezza regolabile, prolungo con vite.

STRUTTURA Art. 505Q: pali mm 38/35 in alluminio, bacchette acciaio, snodo metallo, colore grafite, apertura manuale, altezza regolabile, prolungo con vite.

STRUTTURA Art. 507Q: palo in alluminio mm 50x78, bacchette acciaio, maniglia d'apertura in alluminio con fermo di sicurezza, base a T con sistema di rotazione a 360°. Sistema d'apertura esclusivo Maffei senza corde e manovelle. La base può essere messa davanti o dietro al palo e può avere le ruote.

Pixel Parasol de design

CARACTÉRISTIQUES TECHNIQUES

TISSU: acrylique Dralon 210 g/m², impression numérique pour extérieur, hydrofuge, anti-moisissure, protection UV 20/50+ (selon le design), résistance des couleurs: 7

STRUCTURE Art. 501: mâts 22/25 mm et baleines en acier verni graphite, sans inclinaison, ouverture manuelle, hauteur réglable, pique avec vis

STRUCTURE Art. 503Q: mâts 22/25 mm en acier et baleines paragon couleur graphite, avec inclinaison, ouverture manuelle, hauteur réglable, pique avec vis

STRUCTURE Art. 505Q: mâts en aluminium de 38/35 mm, baleines en acier, inclinaison en métal, couleur graphite, ouverture manuelle, hauteur réglable, pique avec vis

STRUCTURE Art. 507Q: mât en alu 50x78 mm, baleines acier, poignée d'ouverture en alu avec fermeture de sécurité, pied en T pivotant à 360°. Système d'ouverture exclusivité Maffei sans cordes ni manivelles. Le pied peut être placé devant ou derrière le mât et peut avoir des roulettes.

Pixel Design parasol

TECHNICAL FEATURES

FABRIC: Dralon acrylic 210 g/m², digital outdoor printing, water-repellent, anti-mold, UV protection 20/50+ (depending on the design), color fastness: 7

FRAME Art. 501: poles 22/25 mm and steel ribs in graphite colour, without tilt, manual opening, adjustable height, lower with screw

FRAME Art. 503Q: steel poles 22/25 mm and paragon ribs in graphite colour, with tilt, manual opening, adjustable height, lower with screw.

FRAME Art. 505Q: Aluminium poles 38/35 mm, steel ribs, metal tilt, graphite color, manual opening, adjustable height, lower pole with screw

FRAME Art. 507Q: Aluminium pole 50x78 mm, steel ribs, aluminium opening handle with safety stopper, T-shaped steel base, 360° rotating. The opening system without ropes nor crank is Maffei's exclusive. The base can be placed behind or in front of the pole and can have wheels.

Pixel Design Sonnenschirme

TECHNISCHE EIGENSCHAFTEN

STOFF: Dralon Acryl 100% gr 210 qm, Wasserabstoßend imprägniert, mit Digitaldruck, UV schutz 20/50+ (nach Farbe), Lichtechtheit 7

GESTELL Art. 501: Stöcke 22/25 mm und Stahlschienen in Graphit Farbe, ohne Knicker, manuelles Öffnen, höhenverstellbar, Unterstock mit Hebel

GESTELL Art. 503Q: Stahlstöcke 22/25 mm und Paragonchienen in Graphit Farbe, mit Knicker, manuelles Öffnen, höhenverstellbar, Unterstock mit Hebel

GESTELL Art. 505Q: Aluminium poles 38/35 mm, steel ribs, metal tilt, graphite color, manual opening, adjustable height, lower pole with screw

GESTELL Art. 507Q: Stock aus Aluminium 50x78 mm, Aluminium Griff mit Sicherheit, T-Fuß aus Stahl um 360° drehbar. Das Öffnungssystem ohne Seilzug oder Kurbel ist Exklusivität von Maffei. Der Fuß kann vor oder hinter des Stock platziert werden und kann Räder haben.

Art 501

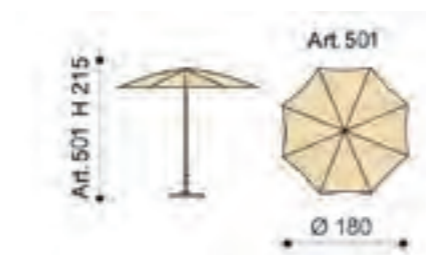

Art 505Q

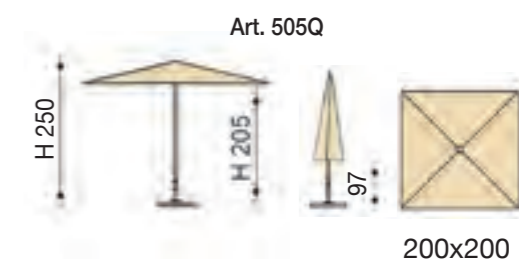

Art 503Q

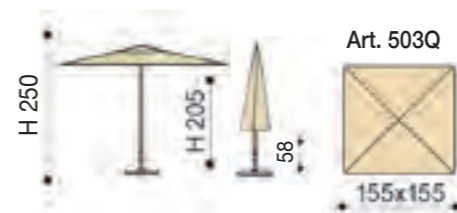

Art 507Q

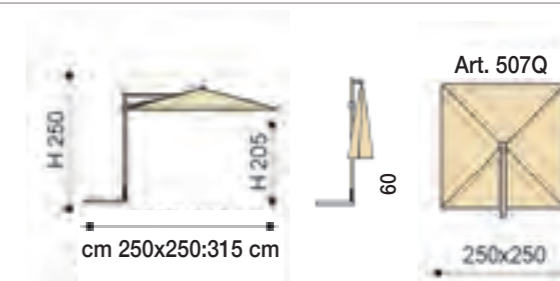

Le misure indicate non includono la base. Con base: + ca.5/10 cm.

Les mesures indiquées ne comprennent pas le pied. Avec pied: + ca.5/10 cm

These sizes don't include the base height. With base: + ca.5/10 cm

Diese Maßnahmen umfassen nicht den Fuß. Mit Fuß: + ca.5/10 cm

 Peso minimo per base: kg 15 per D 180, kg 25 per cm 155x155, kg 30 per cm 200x200, kg 40 per laterale (in caso di base con ruote su laterale raddoppiare contrappeso) **Vedere basi pag. 154**

 Poids minimum pour pied: 15 kg pour D 180, 25 kg pour 155x155 cm, 30 kg pour 200x200 cm, 40 kg pour le deporté (en cas de pied avec roues sur le deporté, doubler le contrepoids) **Voir pieds à la page 154**

 Minimum weight for base: 15 kg for D 180, 25 kg for 155x155 cm, 30 kg for 200x200 cm, 40 kg for side pole (in case of base with wheels on side pole, double the counterweight) **See bases on page 154**

 Mindestgewicht pro Fuß: 15 kg für D 180, 25 kg für 155x155 cm, 30 kg für 200x200 cm, 40 kg für Ampelschirm (im Falle einer Fuß mit Rädern auf Ampelschirm, das Gegengewicht verdoppeln) **Ständer Seite 154**

Colori/Couleurs/Colours/Farben



Labirinto
Labirinto
Labirinto
Labirinto

TREND



Art. 453Q cm 200x200/4

Art. 454 cm 150/6-D300

Art. 455R cm 300x200/6

Art. 455Q cm 240x240/4



Art. 455R ANTRACITE/ANTHRACITE/ANTHRAZIT

Trend **Ombrellone di design con palo alluminio grafite**

CARATTERISTICHE TECNICHE

TESSUTO: PolyMa poliestere gr 210 mq, idrorepellente, antimuffa, protezione UV 50+, resistenza colori 6+. TexMa Olefin gr 190 mq, tinto in pasta, idrorepellente, antimuffa, protezione UV 50+, resistenza colori 7. Il tessuto TexMa può essere usato per alcuni colori speciali. (T).

STRUTTURA: pali mm 38/35 in alluminio, bacchette in acciaio, snodo metallo, apertura manuale, altezza regolabile, prolungo con vite.

Trend **Parasol de design avec mât aluminium graphite**

CARACTÉRISTIQUES TECHNIQUES

TISSU: PolyMa polyester, gr 210 mc, hydrofuge, anti-moisissure, protection UV 50+, résistance couleurs 6+. TexMa Olefin gr 190 mc, teinté en masse, hydrofuge, anti-moisissure, protection UV 50+, résistance couleurs 7. Le tissu TexMa peut être utilisé pour des couleurs spéciales (T).

STRUCTURE: mâts 38/35 mm en aluminium, baleines en acier, inclinaison métal, ouverture manuelle, hauteur réglable, pique avec vis.

Trend **Design parasol with aluminum pole graphite colour**

TECHNICAL FEATURES

FABRIC: PolyMa polyester, gr 210 sm, water-repellent, mouldproof, UV protection 50+, colour fastness 6+. TexMa solution dyed Olefin gr 190 sm, water-repellent, mouldproof, UV protection 50+, colour fastness 7. The fabric TexMa can be used for some special colours.

FRAME: Alu poles 38/35 mm, steel ribs, metal tilt, manual opening, adjustable height, lower pole with screw.

Trend **Design Sonnenschirme mit Alustock Farbe Graphit**

TECHNISCHE EIGENSCHAFTEN

STOFF: PolyMa Polyester, gr 210 qm, Wasserabstoßend imprägniert, Verrottungsfest, UV Schutz 50+, Lichechtheit 6+. TexMa Olefin gr 190 qm Spindüsengefärbted, Wasserabstoßend imprägniert, Verrottungsfest, UV Schutz 50+, Lichtechtheit 7. TexMa Stoff kann für besonders Farben benutzen sein (T).

GESTELL: Stock 38/35 mm aus Aluminium, Streben aus Stahl, Handöffnung, mit Metallknicker, Unterstock mit Schraube.

Le misure indicate non includono la base. Con base: + ca.5/10 cm.

Les mesures indiquées ne comprennent pas le pied. Avec pied: + ca.5/10 cm

These sizes don't include the base height. With base: + ca.5/10 cm

Diese Maßnahmen umfassen nicht den Fuß. Mit Fuß: + ca.5/10 cm

 **Peso per base:** min kg 30. Con peso maggiore avrete più stabilità e sicurezza. **Vedere basi pag. 154**

 **Poids pour pied:** min 30 kg. Avec plus de poids il y aura une majeure stabilité et sécurité. **Voir pieds à la page 154**

 **Weight for base:** min 30 kg. With higher weight, there are better stability and safety. **See bases on page 154**

 **Gewicht für Ständer:** min 30 kg. Mit höher Gewicht, es gibt besser stabilität und Sicherheit. **Ständer Seite 154**

TREND

Colori/Couleurs/Colours/Farben

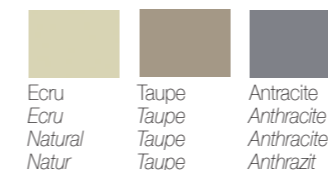

Colori su richiesta/Couleurs sur demande/Colours on demand/Farben auf Anfrage

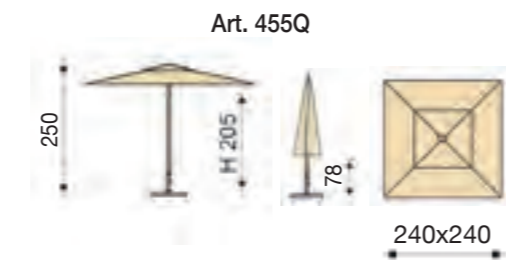
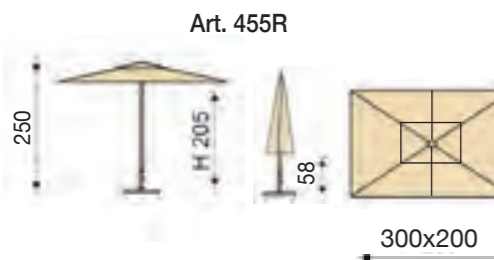
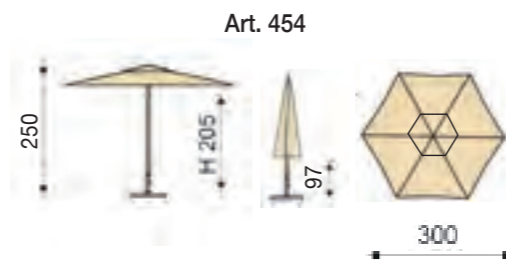
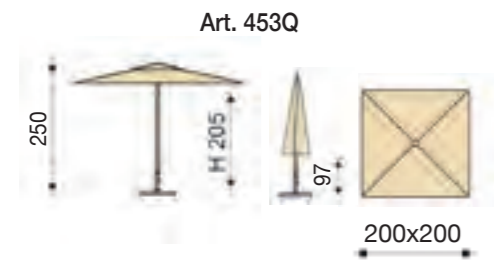
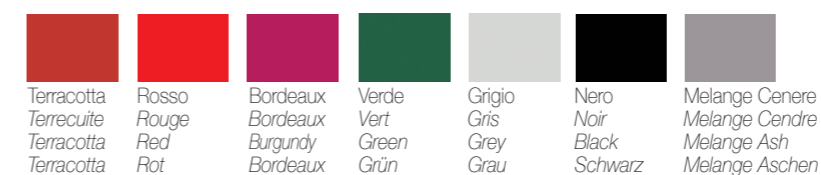





 Ombrellone di design, moderno, pratico, di medie dimensioni con telaio colore **grafite**. L'apertura è manuale ed offre sia la regolazione in altezza, che l'inclinazione. Il tessuto PolyMa in dotazione offre un'eccellente protezione solare.

 Parasol de design, moderne et pratique de moyenne taille, avec structure couleur **graphite**. L'ouverture est manuelle avec possibilité de régler l'hauteur et l'inclinaison. Le tissu PolyMa en dotation offre un'excellente protection solaire.

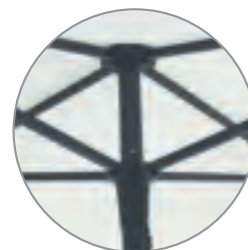



 Modern, easy to use, medium size parasol, with **graphite** colour frame, with manual opening, adjustable height and metal tilt. The Polyma fabric offers an excellent protection.

 Easy-to-use, moderner und mittlere Sonnenschirm mit **Graphitfarbenen** Gestell. Er hat manuelle Öffnung, Knicker und verstellbare Höhe. Der mitgelieferte PolyMa Stoff bietet eine sehr gute Sonnenschutz.







 Bacchette in acciaio e collano
 Baleines en acier et coulan
 Steel ribs and runner
 Stahlstreben und Schieber







 Snodo metallo brunito
 Inclinaison métal foncé
 Matching metal tilt
 Anpassend Metallknicker

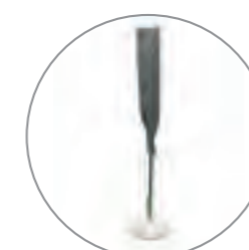

 Bloccaggio a vite
 Serrage à vis
 Lower pole screw
 Schraube für Unterstock





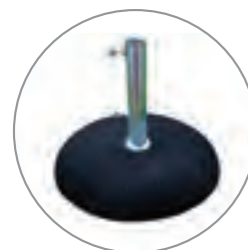

 **Optional** consigliato:
Art. 921 fodera in Mytex
 **Option** conseillée:
Art. 921 Housse en Mytex
 **Recommended option:**
Art. 921 Mytex cover
 **Empfohlene Option:**
Art. 921 Schutzülle aus Mytex

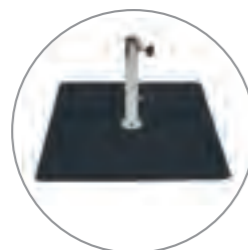





 **Optional:** Base in cemento grafite
 **Option:** Plaque en beton graphit
 **Option:** Graphite concrete base
 **Option:** Betonständer Farbe Graphit

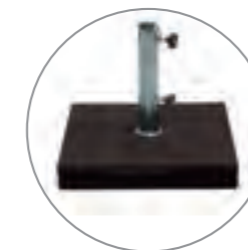





 **Optional:** Base in metallo
 **Option:** Plaque métallique
 **Option:** Metal base
 **Option:** Metallständer



 **Optional:** Base in cemento effetto legno
 **Option:** Pied en béton finition bois
 **Option:** Wooden effect concrete base
 **Option:** Holzoptik Betonplatteständer



 **Optional:** Art. 352. Base da interrare.
 **Option:** Art. 352. Pied alu à enterrer.
 **Option:** Art. 352. Alu ground anchor.
 **Option:** Art. 352. Alu Sockel besteht.

TREND WOOD



Art. 473Q cm 200x200/4
Art. 474 cm 150/6-D300

Art. 475R cm 300x200/6



TREND WOOD

■ ■ Trend Wood Ombrellone di design con palo alluminio effetto legno

CARATTERISTICHE TECNICHE

TESSUTO: PolyMa poliestere gr 210 mq, idrorepellente, antimuffa, protezione UV 50+, resistenza colori 6+. TexMa Olefin gr 190 mq, tinto in pasta, idrorepellente, antimuffa, protezione UV 50+, resistenza colori 7. Il tessuto TexMa può essere usato per alcuni colori speciali. (T).

STRUTTURA: pali mm 38/35 in alluminio, bacchette in acciaio, snodo metallo, apertura manuale, altezza regolabile, prolungo con vite.

■ ■ Trend Wood Parasol de design avec mât aluminium effet bois

CARACTÉRISTIQUES TECHNIQUES

TISSU: PolyMa polyester, gr 210 mc, hydrofuge, anti-moisissure, protection UV 50+, résistance couleurs 6+. TexMa Olefin gr 190 mc, teinté en masse, hydrofuge, anti-moisissure, protection UV 50+, résistance couleurs 7. Le tissu TexMa peut être utilisé pour des couleurs spéciales (T).

STRUCTURE: mâts 38/35 mm en aluminium, baleines en acier, inclinaison métal, ouverture manuelle, hauteur réglable, pique avec vis.

■ ■ Trend Wood Design parasol with aluminum pole wood look

TECHNICAL FEATURES

FABRIC: PolyMa polyester, gr 210 sm, water-repellent, mouldproof, UV protection 50+, colour fastness 6+. TexMa solution dyed Olefin gr 190 sm, water-repellent, mouldproof, UV protection 50+, colour fastness 7. The fabric TexMa can be used for some special colours.

FRAME: Alu poles 38/35 mm, steel ribs, metal tilt, manual opening, adjustable height, lower pole with screw.

■ ■ Trend Wood Design Sonnenschirme mit Alustock Farbe Holzoptik

TECHNISCHE EIGENSCHAFTEN

STOFF: PolyMa Polyester, gr 210 qm, Wasserabstoßend imprägniert, Verrottungsfest, UV Schutz 50+, Lichteinheit 6+. TexMa Olefin gr 190 qm spindüsengefärbt, Wasserabstoßend imprägniert, Verrottungsfest, UV Schutz 50+, Lichteinheit 7. TexMa Stoff kann für besonders Farben benutzen sein (T).

GESTELL: Stock 38/35 mm aus Aluminium, Streben aus Stahl, Handöffnung, mit Metallknicker, Unterstock mit Schraube.

Le misure indicate non includono la base. Con base: + ca.5/10 cm.

Les mesures indiquées ne comprennent pas le pied. Avec pied: + ca.5/10 cm

These sizes don't include the base height. With base: + ca.5/10 cm

Diese Maßnahmen umfassen nicht den Fuß. Mit Fuß: + ca.5/10 cm

Kg Peso per base: min kg 30. Con peso maggiore avrete più stabilità e sicurezza. **Vedere basi pag. 154**

Kg Poids pour pied: min 30 kg. Avec plus de poids il y aura une majeure stabilité et sécurité. **Voir pieds à la page 154**

Kg Weight for base: min 30 kg. With higher weight, there are better stability and safety. **See bases on page 154**

Kg Gewicht für Ständer: min 30 kg. Mit höher Gewicht, es gibt besser stabilität und Sicherheit. **Ständer Seite 154**

TREND WOOD

Colori/Couleurs/Colours/Farben

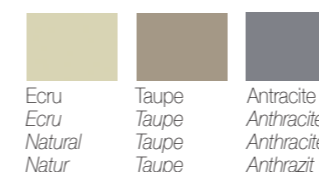

Colori su richiesta/Couleurs sur demande/Colours on demand/Farben auf Anfrage

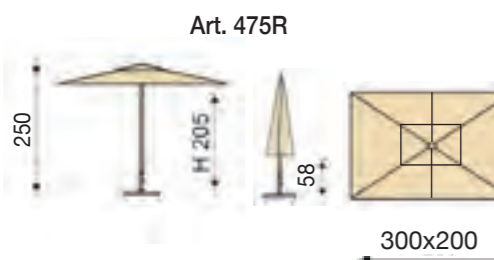
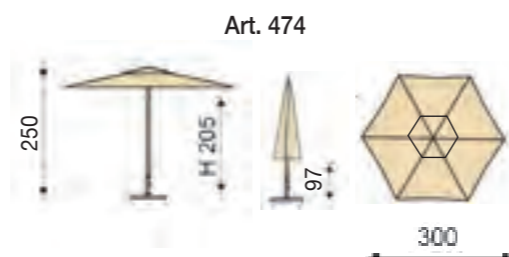
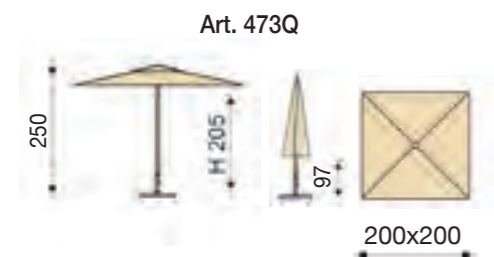

■ ■ Ombrellone di design, moderno, pratico, di medie dimensioni con palo alluminio **effetto legno** e bacchette grafito. L'apertura è manuale ed offre sia la regolazione in altezza, che l'inclinazione. Il tessuto PolyMa in dotazione offre un'eccellente protezione solare.

■ ■ Parasol de design, moderne et pratique de moyenne taille, avec mât alu **effet bois** et baleines couleur graphite. L'ouverture est manuelle avec possibilité de régler l'hauteur et l'inclinaison. Le tissu PolyMa en dotation offre un'excellente protection solaire.

■ ■ Modern, easy to use, medium size parasol, with aluminium **wood look** poles and graphite colour ribs with manual opening, adjustable height and metal tilt. The Polyma fabric offers an excellent protection.

■ ■ Easy-to-use, moderner und mittlere Größe Sonnenschirm mit **Holzoptik** Stock und Graphitfarbenen Gestell. Er hat manuelle Öffnung, eine verstellbare Höhe und Knicker.

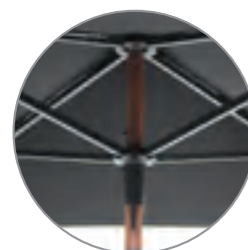

■ Bacchette in acciaio e collano
■ Baleines en acier et coulan
■ Steel ribs and runner
■ Stahlstreben und Schieber



■ Snodo metallo brunito
■ Inclinaison métal foncé
■ Matching metal tilt
■ Anpassend Metallknicker



■ Bloccaggio a vite
■ Serrage à vis
■ Lower pole screw
■ Schraube für Unterstock



■ **Optional** consigliato:
Art. 921 fodera in Mytex
■ **Option** consigliata:
Art. 921 Housse en Mytex
■ **Recommended option:**
Art. 921 Mytex cover
■ **Empfohlene Option:**
Art. 921 Schutzülle aus Mytex



■ **Optional:** Base in graniglia
■ **Option:** Pied en grès
■ **Option:** Grit base
■ **Option:** Betonständer



■ **Optional:** Base in metallo
■ **Option:** Plaque métallique
■ **Option:** Metal base
■ **Option:** Metallständer

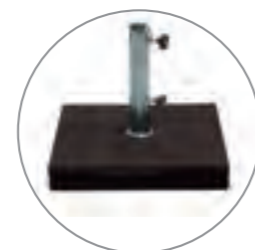

■ **Optional:** Base in cemento effetto legno
■ **Option:** Pied en béton finition bois
■ **Option:** Wooden effect concrete base
■ **Option:** Holzoptik Betonplatteständer



■ **Optional:** Art. 352. Base da interrare.
■ **Option:** Art. 352. Pied alu à enterrer.
■ **Option:** Art. 352. Alu ground anchor.
■ **Option:** Art. 352. Alu Sockel besteht.

TREND ICE



Art. 463Q cm 200x200/4

Art. 464 cm 150/6-D300



Art. 464 BIANCO/BLANC/WHITE/WEISS

TREND ICE

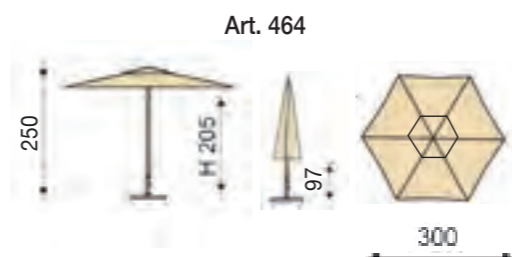
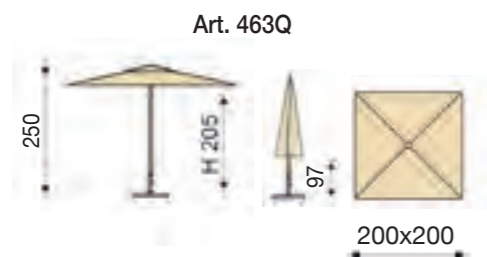

Art. 463Q
 Ombrellone di design, moderno, pratico, di medie dimensioni con telaio **bianco**. L'apertura è manuale ed offre sia la regolazione in altezza, che l'inclinazione. Il tessuto PolyMa in dotazione offre un'eccellente protezione solare.

Art. 464
 Parasol de design, moderne et pratique de moyenne taille, avec structure **blanche**. L'ouverture est manuelle avec possibilité de régler l'hauteur et l'inclinaison. Le tissu PolyMa en dotation offre un'excellente protection solaire.

Art. 463Q
 Modern, easy to use, medium size parasol, with **white** frame, with manual opening, adjustable height and metal tilt. The Polyma fabric offers an excellent protection.

Art. 464
 Easy-to-use, moderner und mittlegroßer Sonnenschirm mit **Weißem** Gestell. Er hat manuelle Öffnung, Knicker und verstellbare Höhe. Der mitgelieferte PolyMa Stoff bietet eine sehr gute Sonnenschutz.



■ Bacchette in acciaio e collano
 ■ Baleines en acier et coulan
 ■ Steel ribs and runner
 ■ Stahlstreben und Schieber



■ Snodo metallo
 ■ Inclinaison métal
 ■ Metal tilt
 ■ Metallknicker



■ Bloccaggio a vite
 ■ Serrage à vis
 ■ Lower pole screw
 ■ Schraube für Unterstock



■ **Optional** consigliato:
 Art. 921 fodera in Mytex
 ■ **Option** conseillée:
 Art. 921 Housse en Mytex
 ■ **Recommended option:**
 Art. 921 Mytex cover
 ■ **Empfohlene Option:**
 Art. 921 Schutzülle aus Mytex



■ **Optional:** Base in graniglia
 ■ **Option:** Pied en grès
 ■ **Option:** Grit base
 ■ **Option:** Betonständer



■ **Optional:** Base in metallo
 ■ **Option:** Plaque métallique
 ■ **Option:** Metal base
 ■ **Option:** Metallständer



■ **Optional:** Base in cemento effetto legno
 ■ **Option:** Pied en béton finition bois
 ■ **Option:** Wooden effect concrete base
 ■ **Option:** Holzoptik Betonplatteständer



■ **Optional:** Art. 352. Base da interrare.
 ■ **Option:** Art. 352. Pied alu à enterrer.
 ■ **Option:** Art. 352. Alu ground anchor.
 ■ **Option:** Art. 352. Alu Sockel besteht.

■ Trend Ice Ombrellone di design con palo alluminio bianco

CARATTERISTICHE TECNICHE

TESSUTO: PolyMa poliestere gr 210 mq, idrorepellente, antimuffa, protezione UV 50+, resistenza colori 6+. TexMa Olefin gr 190 mq, tinto in pasta, idrorepellente, antimuffa, protezione UV 50+, resistenza colori 7. Il tessuto TexMa può essere usato per alcuni colori speciali. (T).

STRUTTURA: pali mm 38/35 in alluminio, bacchette in acciaio, snodo metallo, apertura manuale, altezza regolabile, prolungo con vite.

■ Trend Ice Parasol de design avec mât aluminium blanc

CARACTÉRISTIQUES TECHNIQUES

TISSU: PolyMa polyester, gr 210 mc, hydrofuge, anti-moisissure, protection UV 50+, résistance couleurs 6+. TexMa Olefin gr 190 mc, teinté en masse, hydrofuge, anti-moisissure, protection UV 50+, résistance couleurs 7. Le tissu TexMa peut être utilisé pour des couleurs spéciales (T).

STRUCTURE: mâts 38/35 mm en aluminium, baleines en acier, inclinaison métal, ouverture manuelle, hauteur réglable, pique avec vis.

■ Trend Ice Design parasol with aluminum pole white

TECHNICAL FEATURES

FABRIC: PolyMa polyester, gr 210 sm, water-repellent, mouldproof, UV protection 50+, colour fastness 6+. TexMa solution dyed Olefin gr 190 sm, water-repellent, mouldproof, UV protection 50+, colour fastness 7. The fabric TexMa can be used for some special colours.

FRAME: Alu poles 38/35 mm, steel ribs, metal tilt, manual opening, adjustable height, lower pole with screw.

■ Trend Ice Design Sonnenschirme mit Alustock Farbe Weiß

TECHNISCHE EIGENSCHAFTEN

STOFF: PolyMa Polyester, gr 210 qm, Wasserabstoßend imprägniert, Verrottungsfest, UV Schutz 50+, Lichechtheit 6+. TexMa Olefin gr 190 qm spindüsengefärbt, Wasserabstoßend imprägniert, Verrottungsfest, UV Schutz 50+, Lichtechtheit 7. TexMa Stoff kann für besonders Farben benutzen sein (T).

GESTELL: Stock 38/35 mm aus Aluminium, Streben aus Stahl, Handöffnung, mit Metallknicker, Unterstock mit Schraube.

Le misure indicate non includono la base. Con base: + ca.5/10 cm.

Les mesures indiquées ne comprennent pas le pied. Avec pied: + ca.5/10 cm

These sizes don't include the base height. With base: + ca.5/10 cm

Diese Maßnahmen umfassen nicht den Fuß. Mit Fuß: + ca.5/10 cm

kg Peso per base: min kg 30. Con peso maggiore avrete più stabilità e sicurezza. **Vedere basi pag. 154**

kg Poids pour pied: min 30 kg. Avec plus de poids il y aura une majeure stabilité et sécurité. **Voir pieds à la page 154**

kg Weight for base: min 30 kg. With higher weight, there are better stability and safety. **See bases on page 154**

kg Gewicht für Ständer: min 30 kg. Mit höher Gewicht, es gibt besser stabilität und Sicherheit. **Ständer Seite 154**

TREND ICE

Colori/Couleurs/Colours/Farben



Bianco
 Blanc
 White
 Weiss



Melange avocado
 Melange avocado
 Melange avocado
 Melange avocado

KRONOS



Art. 134 cm 100/10-D200
Art. 135/6 cm 125/6-D250

Art. 136Q cm 200x200/4
Art. 136R cm 240x150/4



Art. 134 ROSSO/ROUGE/RED/ROT



Art. 136Q BIANCO/BLANC/WHITE/WEISS



Art. 135/6 GIALLO/JAUNE/YELLOW/GELB



Art. 136R ECRU/NATURAL/NATUR

KRONOS

■ Ombrellone di design dall'aspetto moderno e lineare, senza volanti, con struttura colore grafite. Proposto in una gamma vasta di colori, si adatta a molti usi. Può essere accostato all'ombrellone laterale Trend, ai prodotti della linea Trend ed ai cuscini della serie Allegro. L'apertura è manuale, l'altezza regolabile ed il tessuto offre un'eccellente protezione.

■ Parasol de design, moderne et linéaire, sans lambrequins, avec structure couleur graphite. La gamme de couleurs proposée est large et s'adapte à plusieurs utilisations. Il peut être combiné avec les parasols Trend déportés, les parasols de la ligne Trend et aux coussins Allegro. L'ouverture est manuelle et offre la possibilité de régler l'hauteur et l'inclinaison. Le tissu PolyMa en dotation offre un'excellente protection solaire.

■ Modern and linear design parasol, without valance, with graphite colour frame. The offered colour range is wide and so it's perfect for many situations. It can be combined to the Trend side pole parasol, to the Trend parasols and to the Allegro cushions as well. The opening is manual, the height is adjustable and it can be tilted. The PolyMa fabric offers an excellent protection.

■ Moderner und linear design Sonnenschirm, ohne Volants, mit Graphitfarbe Gestell. Trend hat eine breite Farbpalette, so kann er zu viele Anwendungen passen. Er kann auch mit Trend Ampleschirm, Trend Sonnenschirm und Allegro Polster kombiniert sein. Es gibt manuelle Öffnung, verstellbare Höhe und Knicker. Der PolyMa mitgelieferte Stoff bietet eine sehr gute Sonnenschutz.



- Struttura in acciaio con snodo (D 200)
- Structure en acier avec inclinaison (D 200)
- Steel frame with metal tilt (D 200)
- Stahlgestell mit Metallknicker (D 200)



- Struttura in acciaio con snodo (altre misure)
- Structure en acier avec inclinaison (autres tailles)
- Steel frame with metal tilt (other sizes)
- Stahlgestell mit knicker (andere Größen)



- Prolungo con vite
- Pique avec serrage à vis
- Lower pole with screw clip
- Unterstock mit Schraube



- Puntine a tasca
- Embouts à poche
- Pocket tips
- Taschenspitzen



- **Optional:** Base in graniglia
- **Option:** Pied en grès
- **Option:** Grit base
- **Option:** Betonständer

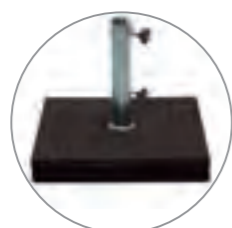

- **Optional:** Base in cemento effetto legno
- **Option:** Pied en béton finition bois
- **Option:** Wooden effect concrete base
- **Option:** Holzoptik Betonplatteständer



- **Optional:** Base in metallo calpestabile
- **Option:** Plaque métallique
- **Option:** Metal base
- **Option:** Metallständer

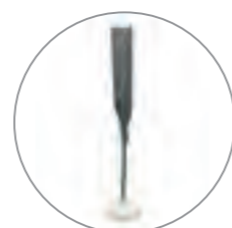

- **Optional** consigliato: Art. 920 per D 200, Art. 921 per altre misure
- **Option** conseillée: Art. 920 pour D 200, Art. 921 pour autres tailles
- **Recommended option:** Art. 920 for D 200, Art. 921 for other sizes
- **Empfohlene Option:** Art. 920 für D 200, Art. 921 für andere Größen

■ Kronos Ombrellone di design senza volanti

CARATTERISTICHE TECNICHE

TESSUTO: PolyMa poliestere gr 210 mq, idrorepellente, antimuffa, protezione UV 50+, resistenza colori 6+.

STRUTTURA: pali mm 27/30 in acciaio, bacchette paragon, (acciaio su D 200), struttura colore grafite, snodo metallo, apertura manuale, altezza regolabile, prolungo con vite zincato e verniciato.

■ Kronos Parasol de design sans lambrequins

CARACTÉRISTIQUES TECHNIQUES

TISSU: PolyMa Polyester, gr 210 mc, hydrofuge, anti-moisissure, protection UV 50+, résistance couleurs 6+.

STRUCTURE: mâts mm 27/30 en acier, baleines paragon, (acier sur D 200), structure couleur graphite, inclinaison métal, ouverture manuelle, hauteur réglable, pique zingué et vernis avec vis de serrage.

■ Kronos Design parasol without valances

TECHNICAL FEATURES

FABRIC: PolyMa Polyester gr 210 sm, water-repellent, mouldproof, UV protection 50+, colour fastness 6+.

FRAME: steel poles 27/30 mm, paragon ribs (steel ribs for D 200), graphite colour frame, metal tilt, manual opening, adjustable height, galvanised and coated lower pole with screw.

■ Kronos Design Sonnenschirm ohne Volants

TECHNISCHE EIGENSCHAFTEN

STOFF: PolyMa Polyester gr 210 qm, Wasserabstoßend imprägniert, Verrottungsfest, UV Schutz 50+, Lichtechtheit 6+.

GESTELL: Stock mm 27/30 aus Stahl, paragon Streben (Stahlstreben für D 200), Farbe Graphit, Handöffnung, höhenverstellbar, galvanisierter und lackierter Unterstock mit Schraube.

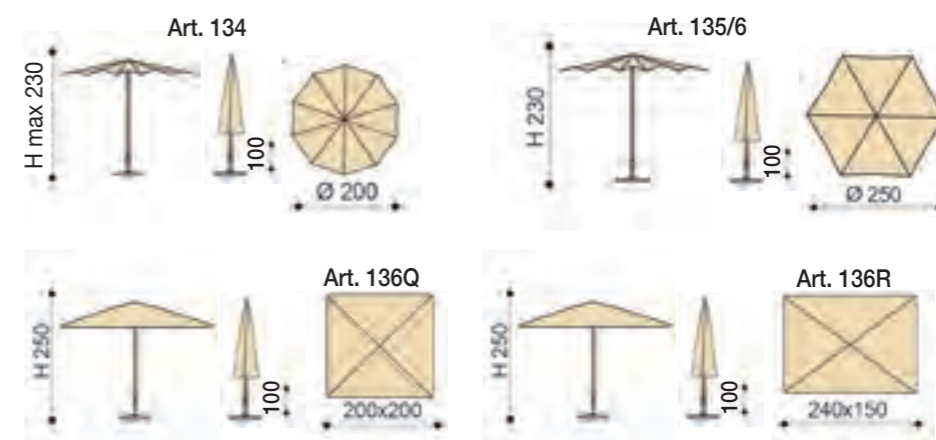

Le misure indicate non includono la base. Con base: + ca.5/10 cm.
 Les mesures indiquées ne comprennent pas le pied. Avec pied: + ca.5/10 cm
 These sizes don't include the base height. With base: + ca.5/10 cm
 Diese Maßnahmen umfassen nicht den Fuß. Mit Fuß: + ca.5/10 cm

kg Peso per base: min kg 20 per D 200, min kg 30 per altre misure. Con peso maggiore avrete più stabilità e sicurezza.
Vedere basi pag. 154

kg Poids pour pied: min 20 kg pour taille D 200, min 30 pour autres tailles. Avec plus de poids il y aura une majeure stabilité et sécurité. **Voir pieds à la page 154**

kg Weight for base: min 20 kg for D 200, min 30 kg for other sizes. With higher weight, there are better stability and safety.
See bases on page 154

kg Gewicht für Ständer: min 20 kg for D 200, min 30 kg für andere Größen. Mit höher Gewicht, es gibt besser stabilität und Sicherheit. **Ständer Seite 154**

Colori/Couleurs/Colours/Farben Art. 135/6 - 136Q - 136R

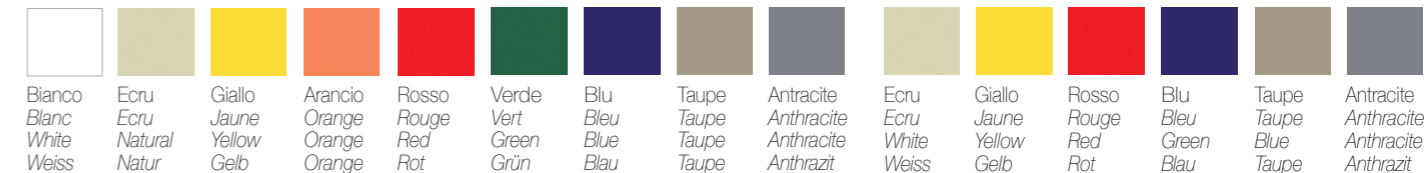

BORDER



Art. 42B cm 100/10-D200

Art. 44BR cm 210x130/4

Art. 46B cm 150/6-D300

Art. 46BQ cm 200x200/4



Art. 46BQ BIANCO/BLANC/WHITE/WEISS



Art. 42B, ECF U/NATURAL/NATUR



Art. 46B ECRU/NATURAL/NATUR

BORDER



Ombrellone di design dall'aspetto moderno ed elegante, grazie alle **cuciture ed alla bordatura in tinta con il telaio**. Proposto in una gamma vasta di colori e dimensioni, per adattarsi alle più diverse esigenze, rende l'ambiente esterno molto gradevole. Completa la gamma l'ombrellone laterale Border.

Parasol de design, moderne et élégant, grâce aux **coutures et au bord ton sur ton avec la structure**. La gamme de couleurs et de tailles proposée est large et s'adapte à plusieurs utilisations. Il rend l'extérieur très agréable. La gamme est complétée par le parasol Border déporté.

Modern and elegant design parasol, thanks to the **seams matching the frame**. The offered colour and size range is wide and so it's perfect for many situations and get your outdoor very pleasant. It can be combined to the Border side pole parasol as well.

Modern und eleganter design Sonnenschirm dank der **zur Gestell passenden Nähten**. Border hat eine breite Farbpalette und Größen, so kann er zu viele Anwendungen passen und die Außen sehr angenehm machen. Es paßt zu der Border Ampelschirm.



■ Struttura in acciaio con snodo (D 200)
■ Structure en acier avec inclinaison (D 200)
■ Steel frame with metal tilt (D 200)
■ Stahlgestell mit Metallknicker (D 200)



■ Struttura in acciaio con snodo (rettangolare)
■ Structure en acier avec inclinaison (rectangulaire)
■ Steel frame with metal tilt (rectangular)
■ Stahlgestell mit Metallknicker (rechteckig)



■ Struttura palo alluminio con snodo (D300-quadrato)
■ Structure mât alu avec inclinaison (D300-carré)
■ Frame with alu pole and tilt (D300-square)
■ Gestell mit Alu Stock und Knicker (D300-quadrat)

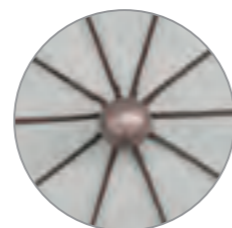

■ Finitura Border
■ Finition Border
■ Border Style
■ Border Style



■ **Optional:** Base in graniglia
■ **Option:** Pied en grès
■ **Option:** Grit base
■ **Option:** Betonständer



■ **Optional:** Base in cemento
■ **Option:** Pied en béton
■ **Option:** Concrete base
■ **Option:** Betonplatteständer

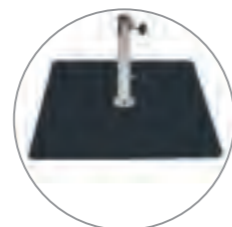

■ **Optional:** Base in metallo
■ **Option:** Plaque métallique
■ **Option:** Metal base
■ **Option:** Metallständer

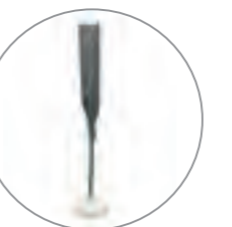

■ **Optional** consigliato: Art. 920 per D 200, Art. 921 per altre misure
■ **Option** conseillée: Art. 920 pour D 200, Art. 921 pour autres tailles
■ **Recommended option:** Art. 920 for D 200, Art. 921 for other sizes
■ **Empfohlene Option:** Art. 920 für D 200, Art. 921 für andere Größen

Border Ombrellone di design con cuciture in tinta al telaio

CARATTERISTICHE TECNICHE

TESSUTO: Dralon Acrilico 100% gr 190 mq, finitura Sun, protezione UV 20/50+ (dipende dal colore), resistenza colori 5-6 (dipende dal colore). L'ombrellone è dotato di laccio chiusura.

STRUTTURA: pali mm 27/30 e bacchette in acciaio, struttura colore grafite, snodo metallo, apertura manuale, altezza regolabile, prolungo con vite zincato e verniciato con vite (misure D200 rettangolare). Pali mm 38/35 in alluminio, bacchette in acciaio, struttura colore grafite, snodo metallo, apertura manuale, altezza regolabile, prolungo con vite (misure D300 e quadrato).

Border Parasol de design avec coutures ton sur ton avec la structure

CARACTÉRISTIQUES TECHNIQUES

TISSU: Dralon Acrylique 100%, gr 190 mc, finition sun, protection UV 20/50+(selon couleur), résistance couleurs 5-6 (selon couleur). Le parasol a une bande de serrage en dotation.

STRUCTURE: mâts 27/30 mm et baleines en acier, structure couleur graphite, inclinaison métal, ouverture manuelle, hauteur réglable, pique zingué et vernis avec vis de serrage (tailles D200 rectangulaire). Mâts 38/35 mm en aluminium, baleines en acier, structure couleur graphite, inclinaison métal, ouverture manuelle, hauteur réglable, pique avec vis de serrage (tailles D300 et carré).

Border Design parasols with matching seams to the frame

TECHNICAL FEATURES

FABRIC: Dralon Acrylic 100% gr 190 sm, sun finish, UV protection 20/50+(depending on colour), colour fastness 5-6 (depending on colour). The parasol has a tie-band for closing.

FRAME: steel poles 27/30 mm and ribs, graphite colour frame, metal tilt, manual opening, adjustable height, galvanised and coated lower pole with screw (sizes D200 rectangular). Aluminium poles 38/35 mm, steel ribs, graphite colour frame, metal tilt, manual opening, adjustable height, lower pole with screw (size D300 and square).

Border Design-Sonnenschirm mit Nähen passenden zur Gestell

TECHNISCHE EIGENSCHAFTEN

STOFF: Dralon Acryl 100%, gr 190 qm Sun beschichtet, UV Schutz 20/50+ (nach Farbe), Lichtechtheit 5/6 (nach Farbe). Das Border Design ist mit eine Paspelhaht zur Gestell passenden. Der Sonnenschirm hat eine Schlingenschluß.

GESTELL: Stöcke 27/30 mm und Streben aus Stahl, Graphitfarbenen Gestell, Handöffnung, höhenverstellbar, galvanisierter und lackierter Unterstock mit Schraube (Großen D200). Stock 38/35 mm aus Alu, Streben aus Stahl, Gestell Graphit Farbe, Handöffnung, höhenverstellbar, galvanisierter und lackierter Unterstock mit Schraube (D300 und quadrat).



Le misure indicate non includono la base. Con base: + ca.5/10 cm.

Les mesures indiquées ne comprennent pas le pied. Avec pied: + ca.5/10 cm

These sizes don't include the base height. With base: + ca.5/10 cm

Diese Maßnahmen umfassen nicht den Fuß. Mit Fuß: + ca.5/10 cm

kg Peso per base: min kg 20 per D 200 e rettangolare, min kg 30 per altre misure. Con peso maggiore avrete più stabilità e sicurezza.

Vedere basi pag. 154

kg Poids pour pied: min 20 kg pour taille D 200 et rectangulaire, min kg 30 pour autres tailles. Avec plus de poids il y aura une majeure stabilité et sécurité. **Voir pieds à la page 154**

kg Weight for base: min 20 kg for D 200 and rectangular, min 30 kg for other sizes. With higher weight, there are better stability and safety. **See bases on page 154**

kg Gewicht für Ständer: min 20 kg for D 200 und rechteckig, min 30 kg für andere Größen. Mit höher Gewicht, es gibt besser stabilität und Sicherheit. **Ständer Seite 154**

Colori/Couleurs/Colours/Farben Art. 42B-46BQ



Bianco
Blanc
White
Weiss

Ecrú
Ecrú
Natural
Natur

Taupe
Taupe
Taupe
Taupe

Rosso
Rouge
Red
Rot

Terracotta
Terrecuite
Terracotta
Terracotta

Mais
Mais
Corn
Mais

Agua de Mar
Agua de Mar
Agua de Mar
Agua de Mar

Grigio
Gris
Grey
Grau

Colori/Couleurs/Colours/Farben Art. 44BR-46B

Bianco
Blanc
White
Weiss

Ecrú
Ecrú
Natural
Natur

Taupe
Taupe
Taupe
Taupe

Agua de Mar
Agua de Mar
Agua de Mar
Agua de Mar



Art. 27 cm 100/10-D200

Art. 28 cm 125/10-D250

Art. 29 cm 140/10-D280



Art. 27 ECRU/NATURAL/NATUR



Art. 28 ANTRACITE/ANTHRACITE/ANTHRAZIT



Art. 27-28-29 ECRU/NATURAL/NATUR



I Ombrellone di design dall'aspetto molto particolare, con ricamo vicino alla punta, che proietta un fiore per terra o sul tavolo. I fori nel tessuto garantiscono un grande effetto antivento e viene fornita una membrana antipioggia trasparente da applicare al bisogno.

P Parasol de design, de l'aspecte spécial, avec une broderie autour de la pointe, qui projette un fleur sur la table ou sur le sol. Ce design garanti un très bon effet anti-vent. En dotation il y a une membrane transparente à utiliser si besoin.

Maffei exclusive design parasol, with an embroidery near the point, that projects a flower on the table or on the floor. This special design offers a very good windproof effect. A transparent membrane is supplied in case of need.

Maffei exklusives Design, mit a Stickerei in der Nähe der Spitze, der eine Blume auf den Tisch oder auf den Boden projiziert. Unser besonderes Design bietet einen sehr gut winddichten Effekt. Eine durchsichtige Membran ist mitgeliefert, wenn gebraucht.



- Struttura acciaio grafite con snodo (D200-D280)
- Structure acier graphite avec inclinaison (D200-D280)
- Steel frame graphite colour with tilt (D200-D280)
- Stahlgestell Graphitfarbe mit Knicker (D200-D280)

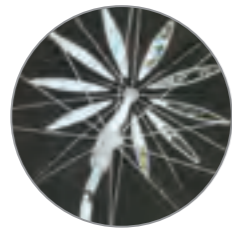

- Struttura acciaio bianca con snodo (D250)
- Structure acier blanche avec inclinaison (D250)
- Steel frame white colour with tilt (D250)
- Weisses Stahlgestell mit Knicker (D250)



- Membrana trasparente
- Membrane transparente
- Transparent membrane
- Transparent Membran



- Ombra con fiore
- Ombre avec fleur
- Shadow with flower
- Schatten mit Blume



- **Optional:** Base in graniglia
- **Option:** Pied en grès
- **Option:** Grit base
- **Option:** Betonständer

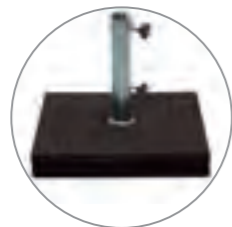

- **Optional:** Base in cemento effetto legno
- **Option:** Pied en béton finition bois
- **Option:** Wooden effect concrete base
- **Option:** Holzoptik Betonplatteständer

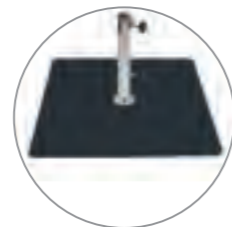

- **Optional:** Base in metallo
- **Option:** Plaque métallique
- **Option:** Metal base
- **Option:** Metallständer

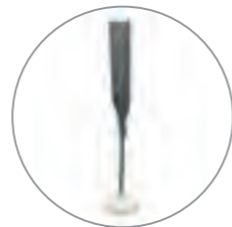

- **Optional** consigliato: Art. 920 per D 200, Art. 921 per altre misure
- **Option** conseillée: Art. 920 pour D 200, Art. 921 pour autres tailles
- **Recommended option:** Art. 920 for D 200, Art. 921 for other sizes
- **Empfohlene Option:** Art. 920 für D 200, Art. 921 für andere Größen

Bea

CARATTERISTICHE TECNICHE

TESSUTO: PolyMa poliestere gr 210 mq, idrorepellente, antimuffa, protezione UV 50+, resistenza colori 6+. L'ombrellone è dotato di laccio chiusura e di membrana in Kristal.

STRUTTURA: pali mm 27/30 e bacchette in acciaio, snodo metallo, apertura manuale, altezza regolabile, prolungo con vite zincato e verniciato. Le misure D 200 e D 280 hanno la struttura colore grafite. La misura D 250 ha la struttura colore bianco.

Bea Parasol de design avec broderie

CARACTÉRISTIQUES TECHNIQUES

TISSU: PolyMa Polyester, gr 210 mc, hydrofuge, anti-moisissure, protection UV 50+, résistance couleurs 6+. Le parasol a une bande de fermeture et d'une membrane transparente en dotation.

STRUCTURE: mâts 27/30 mm et baleines en acier, inclinaison métal, ouverture manuelle, hauteur réglable, pique zingué et vernis avec vis de serrage. Les tailles D 200 et D 280 ont la structure couleur graphite. La taille D 250 a la structure couleur blanc.

Bea Design parasol with embroidery

TECHNICAL FEATURES

FABRIC: PolyMa Polyester gr 210 sm, water-repellent, mouldproof, UV protection 50+, colour fastness 6+. The parasol has a tie-band for closing and a transparent membrane for rain.

FRAME: steel poles 27/30 mm and ribs, metal tilt, manual opening, adjustable height, galvanised and coated lower pole with screw. The frame for sizes D 200 and D 280 is graphite colour, the one for D 250 is white.

Bea Design-Sonnenschirm mit Stickerei

TECHNISCHE EIGENSCHAFTEN

STOFF: PolyMa Polyester gr 210 qm, Wasserabstoßend imprägniert, Verrottungsfest, UV Schutz 50+, Lichtechtheit 6+. Der Sonnenschirm hat eine Schlingenverschluss und eine Membran für Regen.

GESTELL: Stöcke 27/30 mm und Schienen aus Stahl, Metallknicker, Handöffnung, höhenverstellbar, galvanisierter und lackierter Unterstock, mit Schraube. Die Größe D 200 und D 280 haben Graphitfarbe Gestell, anstatt D 250 hat weisses Gestell.



Le misure indicate non includono la base. Con base: + ca.5/10 cm.

Les mesures indiquées ne comprennent pas le pied. Avec pied: + ca.5/10 cm

These sizes don't include the base height. With base: + ca.5/10 cm

Diese Maßnahmen umfassen nicht den Fuß. Mit Fuß: + ca.5/10 cm

kg Peso per base: min kg 20 per D 200 e rettangolare, min kg 30 per altre misure. Con peso maggiore avrete più stabilità e sicurezza. **Vedere basi pag. 154**

kg Poids pour pied: min 20 kg pour taille D 200, min kg 30 pour autres tailles. Avec plus de poids il y aura une majeure stabilité et sécurité. **Voir pieds à la page 154**

kg Weight for base: min 20 kg for D 200, min 30 kg for other sizes. With higher weight, there are better stability and safety. **See bases on page 154**

kg Gewicht für Ständer: min 20 kg for D 200, min 30 kg für andere Größen. Mit höher Gewicht, es gibt besser stabilität und Sicherheit. **Ständer Seite 154**

Colori/Couleurs/Colours/Farben Art. 28



Colori/Couleurs/Colours/Farben Art. 27-29

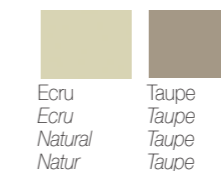

ALLEGRO



Art. 82 cm 100/8-D200
Art. 84 cm 100/10-D200

Art. 85 cm 140/10-D280
Art. 86R cm 240x150/4



Art. 85 ECRU/NATURAL/NATUR



Art. 84-85 ECRU/NATURAL/NATUR



Art. 86R TURCHESE/TURQUOISE/TURQUESE/TURKIS

ALLEGRO



■ Ombrellone di design dall'aspetto classico ed elegante, grazie al volante smerlato ed alla struttura grafite. Proposto in una gamma vasta di colori, si adatta a molti usi. Può essere accostato all'ombrellone laterale Allegro ed ai cuscini della stessa serie. L'apertura è manuale, l'altezza regolabile ed il tessuto offre un'eccellente protezione.

■ Parasol de design, classique et élégant, grâce aux lambrequins festonnés et à la structure couleur graphite. La gamme de couleurs proposée est large et s'adapte à plusieurs utilisations. Il peut être combiné avec les parasols Allegro déportés et aux coussins Allegro. L'ouverture est manuelle et il offre la possibilité de régler l'hauteur et l'inclinaison. Le tissu en dotation offre un'excellente protection solaire.

■ Classic and elegant design parasol, thanks to the scalloped valances and to the graphite colour frame. The offered colour range is wide and so it's perfect for many situations. It can be combined to the Allegro side pole parasol and to the Allegro cushions as well. The opening is manual, the height is adjustable and there is a tilt. The fabric offers an excellent protection.

■ Klassischer und eleganter design Sonnenschirm dank der festonierter Volant un der Graphitfarbe Gestell. Allegro hat eine breite Farbpalette, so kann er zu viele Anwendungen passen. Er kann auch mit Allegro Ampelschirm und Allegro Polster kombiniert sein. Es gibt manuelle Öffnung, verstellbare Höhe und Knicker. Der mitgelieferte Stoff bietet eine sehr gute Sonnenschutz.



- Struttura in acciaio con snodo (rotondo)
- Structure en acier avec inclinaison (rond)
- Steel frame with metal tilt (round)
- Stahlgestell mit Metallknicker (rund)

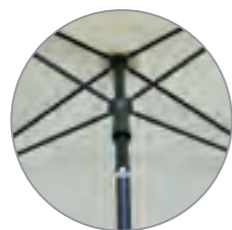

- Struttura in acciaio con snodo (rettangolare)
- Structure en acier avec inclinaison (rectangulaire)
- Steel frame with tilt (rectangular)
- Stahlgestell mit knicker (rechteckig)



- Prolungo con vite
- Pique avec serrage à vis
- Lower pole with screw clip
- Unterstock mit Schraube



- Volante smerlato
- Lambrequin festonné
- Scalloped valance
- Festonierter Volant



- **Optional:** Base in graniglia
- **Option:** Pied en grès
- **Option:** Grit base
- **Option:** Betonständer

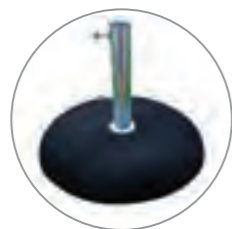

- **Optional:** Base in cemento
- **Option:** Plaque en beton
- **Option:** Concrete base
- **Option:** Betonständer



- **Optional:** Base in metallo
- **Option:** Plaque métallique
- **Option:** Metal base
- **Option:** Metallständer

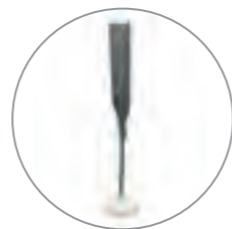

- **Optional** consigliato: Art. 920 per D 200, Art. 921 per altre misure
- **Option** conseillée: Art. 920 pour D 200, Art. 921 pour autres tailles
- **Recommended option:** Art. 920 for D 200, Art. 921 for other sizes
- **Empfohlene Option:** Art. 920 für D 200, Art. 921 für andere Größen

Allegro Ombrellone di design con volante smerlato

CARATTERISTICHE TECNICHE

TESSUTO: PolyMa poliestere gr 210 mq, idrorepellente, antimuffa, protezione UV 50+, resistenza colori 6+.

TexMa Olefin gr 190 mq, tinto in pasta, idrorepellente, antimuffa, protezione UV 50+, resistenza colori 7. Il tessuto TexMa può essere usato per alcuni colori speciali. (T).

STRUTTURA: pali mm 27/30 e bacchette in acciaio, struttura colore grafite, snodo metallo, apertura manuale, altezza regolabile, prolungo con vite zincato e verniciato.

Allegro Parasol de design avec lambrequins festonnés

CARACTÉRISTIQUES TECHNIQUES

TISSU: PolyMa Polyester, gr 210 mc, hydrofuge, anti-moisissure, protection UV 50+, résistance couleurs 6+.

TexMa Olefin gr 190 mc, teinté en masse, hydrofuge, anti-moisissure, protection UV 50+, résistance couleurs 7. Le tissu TexMa peut être utilisé pour des couleurs spéciales (T).

STRUCTURE: mâts 27/30 mm et baleines en acier, structure couleur graphite, inclinaison métal, ouverture manuelle, hauteur réglable, pique zingué et vernis avec vis de serrage.

Allegro Design parasol with scalloped valances

TECHNICAL FEATURES

FABRIC: PolyMa Polyester gr 210 sm, water-repellent, mouldproof, UV protection 50+, colour fastness 6+.

TexMa solution dyed Olefin gr 190 sm, water-repellent, mouldproof, UV protection 50+, colour fastness 7. The fabric TexMa can be used for some special colours (T).

FRAME: steel poles 27/30 mm and ribs, graphite colour frame, metal tilt, manual opening, adjustable height, galvanised and coated lower pole with screw.

Allegro Design-Sonnenschirm mit festonierten Volants

TECHNISCHE EIGENSCHAFTEN

STOFF: PolyMa Polyester gr 210 qm, Wasserabstoßend imprägniert, Verrottungsfest, UV Schutz 50+, Lichtechtheit 6+.

TexMa Olefin gr 190 qm spindlisengefärbtes, Wasserabstoßend imprägniert, Verrottungsfest, UV Schutz 50+, Lichtechtheit 7.

GESTELL: Stock 27/30 mm und Streben aus Stahl, Gestell Graphit Farbe, Handöffnung, galvanisierter und lackierter Unterstock mit Schraube.

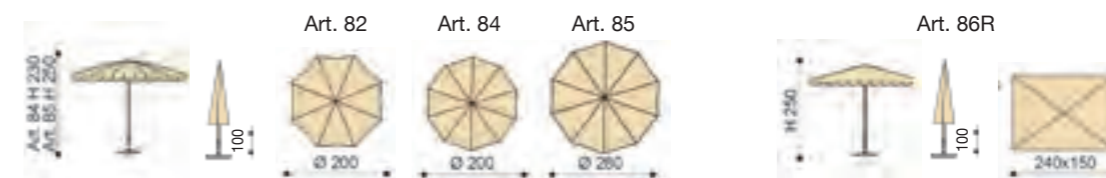

kg Peso per base: min kg 20 per D200, min kg 30 per D280 e rettangolare. Con peso maggiore avrete più stabilità e sicurezza. **Vedere basi pag. 154**

kg Poids pour pied: min 20 kg pour taille D 200, min 30 kg pour taille D 280 et rectangulaire. Avec plus de poids il y aura une majeure stabilité et sécurité. **Voir pieds à la page 154**

kg Weight for base: min 20 kg for D 200, min 30 kg for D 280 and rectangular. With higher weight, there are better stability and safety. **See bases on page 154**

kg GGewicht für Ständer: min 20 kg für D 200, min 30 kg für D 280 und recteckig. Mit höher Gewicht, es gibt besser stabilität und Sicherheit. **Ständer Seite 154**

Colori/Couleurs/Colours/Farben Art. 82



Art. 85



Colori/Couleurs/Colours/Farben Art. 86R



MADERA



Art. 66 cm 140/6-D280



Art. 66 ROSSO/ROUGE/RED/ROT



Art. 66 ECRU/NATURAL/NATUR



MADERA



Ombrellone con palo alluminio effetto legno. La forma esagonale e la modalità costruttiva lo rendono un ombrellone di medie dimensioni facile da maneggiare ed adatto all'uso con arredamento in legno.

Parasol avec mât alu effet bois. La forme hexagonale et les détails techniques permettent d'avoir un parasol de moyenne taille facile et simple à manipuler et parfait en combinaison avec des meubles en bois.

Parasol with wood look aluminium pole. The hexagonale shape and the construction method allow to have a quite big parasol easy to use and perfectly matching wooden furniture.

Sonnenschirm mit Holzoptik Aluminium Stock. Die sechseckige Form und diese Konstruktionsmethode ermöglicht es, ein Produkt einfach zu benutzen und perfekt mit Holzmöbeln zu erhalten.



■ Struttura
■ Structure
■ Frame
■ Gestell



■ Bacchette
■ Baleines
■ Ribs
■ Streben



■ Prolungo con vite
■ Pique avec serrage à vis
■ Lower pole with screw clip
■ Unterstock mit Schraube

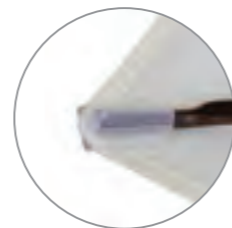

■ Puntina a tasca
■ Aiguillette à poche
■ Pocket tip
■ Taschenspitzen



■ **Optional:** Base in graniglia
■ **Option:** Pied en grès
■ **Option:** Grit base
■ **Option:** Betonständer

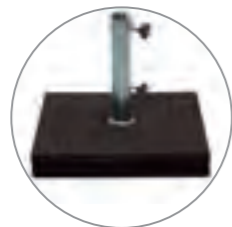

■ **Optional:** Base in cemento effetto legno
■ **Option:** Pied en béton finition bois
■ **Option:** Wooden effect concrete base
■ **Option:** Holzoptik Betonplatteständer

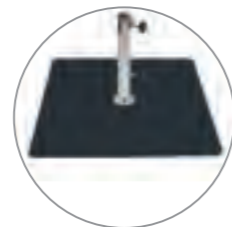

■ **Optional:** Base in metallo
■ **Option:** Plaque métallique
■ **Option:** Metal base
■ **Option:** Metallständer

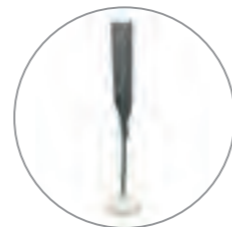

■ **Optional consigliato:** Art. 921 fodera in Mytex
■ **Option conseillée:** Art. 921 Housse en Mytex
■ **Recommended option:** Art. 921 Mytex cover
■ **Empfohlene Option:** Art. 921 Schutzülle aus Mytex

■ ■ Madera Ombrelloni di design con struttura palo alluminio effetto legno

CARATTERISTICHE TECNICHE

TESSUTO: PolyMa poliestere gr 210 mq, idrorepellente, antimuffa, protezione UV 50+, resistenza colori 6+.

L'ombrellone è dotato di laccio di chiusura.

STRUTTURA: pali mm 35/40 in alluminio effetto legno, bacchette paragon marroni, non inclinabile, apertura manuale, altezza regolabile, prolungo con vite.

■ ■ Madera Parasol de design avec mât en alu effet bois

CARACTÉRISTIQUES TECHNIQUES

TISSU: PolyMa Polyester, gr 210 mc, hydrofuge, anti-moisissure, protection UV 50+, résistance couleurs 6+.

Le parasol a une bande de fermeture

STRUCTURE: mâts 35/40 mm en alu effet bois, baleines paragon marron, sans inclinaison, ouverture manuelle, hauteur réglable, pique avec vis de serrage.

■ ■ Madera Design parasol with wood look aluminium pole

TECHNICAL FEATURES

FABRIC: PolyMa Polyester gr 210 sm, water-repellent, mouldproof, UV protection 50+, colour fastness 6+.

FRAME: wood look alu poles 35/40 mm, paragon ribs, without tilt, manual opening, adjustable height, lower pole with screw.

■ ■ Madera Design-Sonnenschirm mit Holzoptik Stock aus Aluminium

TECHNISCHE EIGENSCHAFTEN

STOFF: PolyMa Polyester gr 210 qm, Wasserabstoßend imprägniert, Verrottungsfest, UV Schutz 50+, Lichtechtheit 6+.

GESTELL: Holzoptik Stock 35/40 mm aus Aluminium, Paragon Streben, ohne Knicker, Handöffnung, Unterstock mit Schraube.

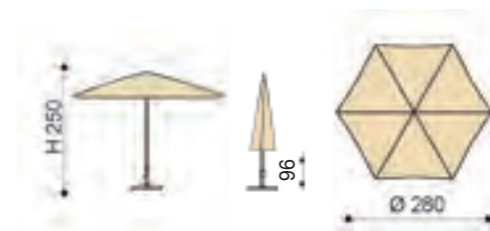

Le misure indicate non includono la base. Con base: + ca.5/10 cm.

Les mesures indiquées ne comprennent pas le pied. Avec pied: + ca.5/10 cm

These sizes don't include the base height. With base: + ca.5/10 cm

Diese Maßnahmen umfassen nicht den Fuß. Mit Fuß: + ca.5/10 cm

■ **Peso per base:** min kg 30. Con peso maggiore avrete più stabilità e sicurezza. **Vedere basi pag. 154**

■ **Poids pour pied:** min kg 30. Avec plus de poids il y aura une majeure stabilité et sécurité. **Voir pieds à la page 154**

■ **Weight for base:** min 30 kg. With higher weight, there are better stability and safety. **See bases on page 154**

■ **Gewicht für Ständer:** min 30. Mit höher Gewicht, es gibt besser stabilität und Sicherheit. **Ständer Seite 154**

Colori/Couleurs/Colours/Farben

Ecru	Taupe	Rosso	Verde	Antracite
Ecru	Taupe	Rouge	Vert	Anthracite
Natural	Taupe	Red	Green	Anthracite
Natur	Taupe	Rot	Grün	Anthrazit

MALTA



Art. 18 cm 100/8-D200 SQ



Art. 18 ANTRACITE/ANTHRACITE/ANTHRAZIT



TAUPE



ANTRACITE/ANTHRACITE/ANTHRAZIT



ROSSO/ROUGE/RED/ROT



TURCHESE/TURQUOISE/TURQUESE/TURKIS



BLU/BLEU/BLUE/BLAU



BISCAY

MALTA



Malta Ombrellone dalla particolare forma semiquadra, con 4 teli larghi e 4 teli stretti. Viene proposto sia nella tradizionale versione bicolore, sia in una più moderna versione monocolora con cuciture bianche in tinta con il telaio.

Malta Parasol avec spéciale forme demi-carrée, avec 4 pointes étroites et 4 pointes larges. Il est proposé et dans la traditionnelle version bicouleur et dans une version plus moderne en teinte unie, avec coutures blanches ton sur ton avec la structure.

Malta Parasol with a special half-squared shape, with 4 narrow panels and 4 large panels. It's proposed both in the traditional 2 colours version and in a more modern version, with seams matching the frame.

Malta Sonnenschirm mit einer besonderer halbquadratisch Form, mit 4 schmalen Keilen und 4 breiten Keilen. Es wird sowohl in der zweifarbigen als auch in einer modernen einfarbigen Version, mit weiße Nähten passenden zur Gestelle, vorgeschlagen.

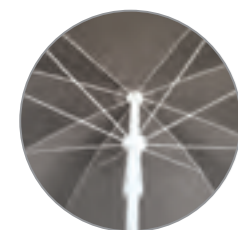

■ Struttura
■ Structure
■ Frame
■ Gestell



■ Prolungo con vite
■ Pique avec serrage à vis
■ Lower pole with screw clip
■ Unterstock mit Schraube



■ Tampus a palla
■ Chapeau a boule
■ Ball top
■ Kugeltop



■ Cuciture
■ Coutures
■ Seams
■ Nähten



■ **Optional:** Base in graniglia
■ **Option:** Pied en grès
■ **Option:** Grit base
■ **Option:** Betonständer

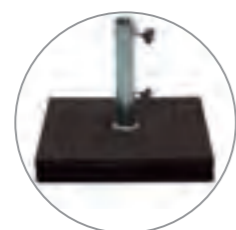

■ **Optional:** Base in cemento effetto legno
■ **Option:** Pied en béton finition bois
■ **Option:** Wooden effect concrete base
■ **Option:** Holzoptik Betonplatteständer

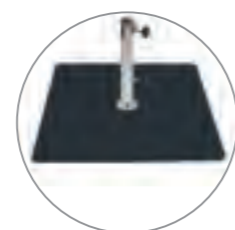

■ **Optional:** Base in metallo
■ **Option:** Plaque métallique
■ **Option:** Metal base
■ **Option:** Metallständer

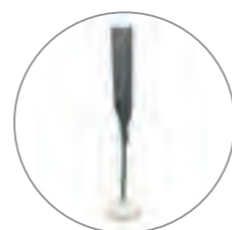

■ **Optional consigliato:** Art. 920 fodera in Mytex
■ **Option conseillée:** Art. 920 Housse en Mytex
■ **Recommended option:** Art. 920 Mytex cover
■ **Empfohlene Option:** Art. 920 Schutzülle aus Mytex

Malta Ombrelloni di design a forma semiquadra

CARATTERISTICHE TECNICHE

TESSUTO: PolyMa poliestere gr 210 mq, idrorepellente, antimuffa, protezione UV 50+, resistenza colori 6+.

TexMa Olefin gr 190 mq, tinto in pasta, idrorepellente, antimuffa, protezione UV 50+, resistenza colori 7. Il tessuto TexMa può essere usato per alcuni colori speciali. (T).

STRUTTURA: pali mm 27/30 e bacchette in acciaio, colore bianco, inclinabile, apertura manuale, altezza regolabile, prolungo zincato con vite.

Malta Parasol de design avec forme semi-carrée

CARACTÉRISTIQUES TECHNIQUES

TISSU: PolyMa Polyester, gr 210 mc, hydrofuge, anti-moisissure, protection UV 50+, résistance couleurs 6+.

TexMa Olefin gr 190 mc, teinté en masse, hydrofuge, anti-moisissure, protection UV 50+, résistance couleurs 7. Le tissu TexMa peut être utilisé pour des couleurs spéciales (T).

STRUCTURE: mâts 27/30 mm et baleines en acier, couleur blanc, avec inclinaison, ouverture manuelle, hauteur réglable, pique zingué avec vis de serrage.

Malta Design parasol with half-squared shape

TECHNICAL FEATURES

FABRIC: PolyMa Polyester gr 210 sm, water-repellent, mouldproof, UV protection 50+, colour fastness 6+.

TexMa solution dyed Olefin gr 190 sm, water-repellent, mouldproof, UV protection 50+, colour fastness 7. The fabric TexMa can be used for some special colours (T).

FRAME: white colour steel poles 27/30 mm and ribs, with metal tilt, manual opening, adjustable height, lower pole with screw.

Malta Design-Sonnenschirm mit halbquadratisch Form

TECHNISCHE EIGENSCHAFTEN

STOFF: PolyMa Polyester gr 210 qm, Wasserabstoßend imprägniert, Verrottungsfest, UV Schutz 50+, Lichtechtheit 6+.

TexMa Olefin gr 190 qm spindüsengefärbtes, Wasserabstoßend imprägniert, Verrottungsfest, UV Schutz 50+, Lichtechtheit 7.

GESTELL: Weiss lackiert Stock 27/30 mm und Streben aus Stahl, mit Metalknicker, Handöffnung, galvanisiert Unterstock mit Schraube.

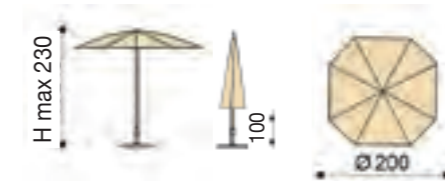

Le misure indicate non includono la base. Con base: + ca.5/10 cm.

Les mesures indiquées ne comprennent pas le pied. Avec pied: + ca.5/10 cm

These sizes don't include the base height. With base: + ca.5/10 cm

Diese Maßnahmen umfassen nicht den Fuß. Mit Fuß: + ca.5/10 cm

kg Peso per base: min kg 15. Con peso maggiore avrete più stabilità e sicurezza. **Vedere basi pag. 154**

kg Poids pour pied: min kg 15. Avec plus de poids il y aura une majeure stabilité et sécurité. **Voir pieds à la page 154**

kg Weight for base: min 15 kg. With higher weight, there are better stability and safety. **See bases on page 154**

kg Gewicht für Ständer: min 15. Mit höher Gewicht, es gibt besser stabilität und Sicherheit. **Bases Seite 154**

Colori/Couleurs/Colours/Farben



ESTRELLA - STAR



ESTRELLA
Art. 55 cm 125/10-D250

STAR
Art. 56 cm 125/10-D250



Art. 56 BIANCO/GRIGIO - BLANC/GRIS
WHITE/GREY - WEISS/GRAU



Art. 55 ECRU/NATURAL/NATUR

|104|



|105|

ESTRELLA - STAR



Ombrellone di design esclusivo Maffei con due finiture: Estrella tinta unita e Star bicolore. Il design con forma piatta ed a stella conferisce un aspetto molto moderno e rende unico l'ambiente esterno.

Parasol de design exclusivité Maffei proposé en deux versions: Estrella teinte unie et Star bicouleur. La forme plate à l'étoile donne une design très moderne et rend unique l'extérieur.

Design parasol, Maffei exclusivity, with two versions: Estrella uni colour and Star 2-colours. The flat star shape gives a very modern design and is able to get the outdoor unique.

Maffei exclusives Design, hat dieser Sonnenschirm zwei Ausführungs: Estrella uni Farbe, Star 2-Farben. Die flache Sternform ist sehr modern und kann die Außen einzigartig machen.



■ Struttura in acciaio con snodo
■ Structure en acier avec inclinaison
■ Steel frame with metal tilt
■ Stahlgestell mit Metallknicker



■ Bacchette
■ Baleines
■ Ribs
■ Streben



■ Prolungo con vite
■ Pique avec serrage à vis
■ Lower pole with screw clip
■ Unterstock mit Schraube

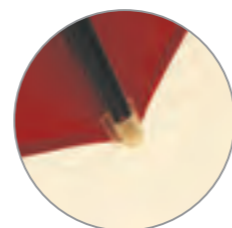

■ Puntina a tasca
■ Embouts à poche
■ Pocket tip
■ Taschenspitzen



■ **Optional:** Base in graniglia
■ **Option:** Pied en grès
■ **Option:** Grit base
■ **Option:** Betonständer



■ **Optional:** Base in cemento effetto legno
■ **Option:** Pied en béton finition bois
■ **Option:** Wooden effect concrete base
■ **Option:** Holzoptik Betonplatteständer

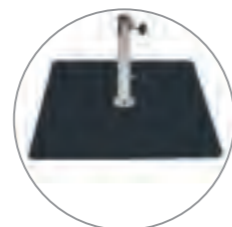

■ **Optional:** Base in metallo
■ **Option:** Plaque métallique
■ **Option:** Metal base
■ **Option:** Metallständer

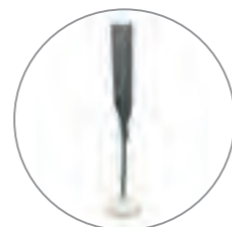

■ **Optional consigliato:** Art. 921 fodera in Mytex
■ **Option conseillée:** Art. 921 Housse en Mytex
■ **Recommended option:** Art. 921 Mytex cover
■ **Empfohlene Option:** Art. 921 Schutzülle aus Mytex

Estrella-Star Ombrelloni di design con forma a stella

CARATTERISTICHE TECNICHE

TESSUTO ESTRELLA: PolyMa poliestere gr 210 mq, idrorepellente, antimuffa, protezione UV 50+, resistenza colori 6+.
L'ombrellone è dotato di laccio di chiusura.

TESSUTO STAR: Dralon acrilico gr 190 mq, finitura Sun, protezione UV 20/50+ (dipende dal colore), resistenza colori 5-6 (dipende dal colore).

STRUTTURA: pali mm 27/30 in acciaio, bacchette paragon, struttura colore grafite, snodo metallo, apertura manuale, altezza regolabile, prolungo zincato e verniciato con vite.

Estrella-Star Parasol de design avec forme à l'étoile

CARACTÉRISTIQUES TECHNIQUES

TISSU ESTRELLA: PolyMa Polyester, gr 210 mc, hydrofuge, anti-moisissure, protection UV 50+, résistance couleurs 6+.
Le parasol a une bande de fermeture.

TISSU STAR: Dralon acrylique gr 190 mc, finition Sun, protection UV 20/50+ (selon couleur), résistance couleurs 5-6 (selon couleur).

STRUCTURE: mâts 27/30 mm en acier, baleines paragon, structure couleur graphite, inclinaison métal, ouverture manuelle, hauteur réglable, pique zingué et vernis avec vis de serrage.

Estrella-Star Design parasol star-shaped

TECHNICAL FEATURES

FABRIC ESTRELLA: PolyMa Polyester gr 210 sm, water-repellent, mouldproof, UV protection 50+, colour fastness 6+.
The parasol has a tie-band for closing.

FABRIC STAR: Dralon Acrylic gr 190 sm, Sun finish, UV protection UV 20/50+ (depends on colour), colour fastness 5-6 (depends on colour).

FRAME: steel poles 27/30 mm, paragon ribs, graphite colour frame, metal tilt, manual opening, adjustable height, galvanised and coated lower pole with screw.

Estrella-Star Design-Sonnenschirm mit Sternform

TECHNISCHE EIGENSCHAFTEN

STOFF ESTRELLA: PolyMa Polyester gr 210 qm, Wasserabstoßend imprägniert, Verrottungsfest, UV Schutz 50+, Lichtechtheit 6+.
Der Sonnenschirm hat eine Schlingenverschluss.

STOFF STAR: Dralon Acryl, gr 190 qm Sun beschichtet, UV Schutz 20/50+ (nach Farbe), Lichtechtheit 5/6 (nach Farbe).

GESTELL: Stock 27/30 mm aus Stahl, paragon Streben, Gestell Graphit Farbe, Handöffnung, galvanisierter und lackierter Unterstock mit Schraube.

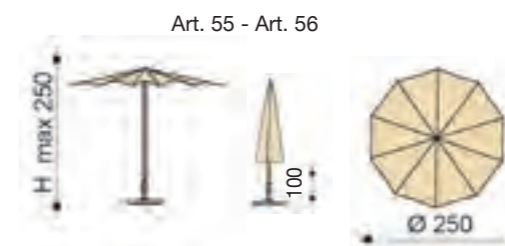

Le misure indicate non includono la base. Con base: + ca.5/10 cm.

Les mesures indiquées ne comprennent pas le pied. Avec pied: + ca.5/10 cm

These sizes don't include the base height. With base: + ca.5/10 cm

Diese Maßnahmen umfassen nicht den Fuß. Mit Fuß: + ca.5/10 cm

kg Peso per base: min kg 30. Con peso maggiore avrete più stabilità e sicurezza. **Vedere basi pag. 154**

kg Poids pour pied: min kg 30. Avec plus de poids il y aura une majeure stabilité et sécurité. **Voir pieds à la page 154**

kg Weight for base: min 30 kg. With higher weight, there are better stability and safety. **See bases on page 154**

kg Gewicht für Ständer: min 30. Mit höher Gewicht, es gibt besser stabilität und Sicherheit. **Ständer Seite 154**

Colori/Couleurs/Colours/Farben Art. 55

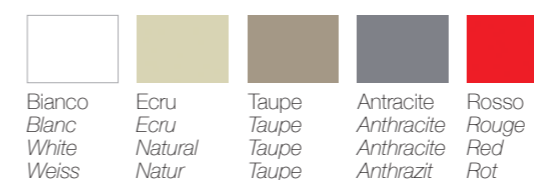

Bianco
Blanc
White
Weiss

Ecrú
Ecrú
Natural
Natur

Taupe
Taupe
Taupe
Taupe

Antracite
Anthracite
Anthracite
Anthrazit

Rosso
Rouge
Red
Rot

Colori/Couleurs/Colours/Farben Art. 56

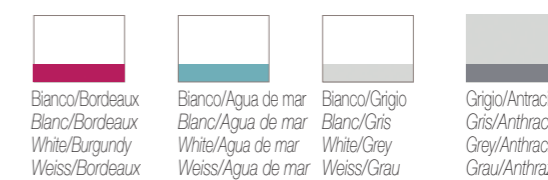

Bianco/Bordeaux
Blanc/Bordeaux
White/Burgundy
Weiss/Bordeaux

Bianco/Agua de mar
Blanc/Agua de mar
White/Agua de mar
Weiss/Agua de mar

Bianco/Grigio
Blanc/Gris
White/Grey
Weiss/Grau

Grigio/Antracite
Gris/Anthracite
Grey/Anthracite
Grau/Anthrazit

OMBRELLONI UTILITY E CLASSICI

Ombrelloni utility e classici. La qualità, lo stile, la durata sono il plusvalore degli ombrelloni Maffei più tradizionali

PARASOLS UTILITY ET CLASSIQUES

*Parasols utility et classiques.
La qualité, le dessin, la durabilité
sont la plus-value des parasols Maffei
plus classiques*

UTILITY AND CLASSIC PARASOLS

*Utility and classic parasols.
The quality, the design, the long lasting
are the added value received by our
customer on our traditional parasols*

UTILITY UND KLASSISCHEN SONNENSCHIRME

*Qualität, Design, Dauer sind
der Mehrwert den unsere Kunden
an klassischen Sonnenschirme erhalten.*



INOX



Art. 92 cm 100/10-D200



Art. 92 RIGA B/BLU - RAYE B/BLEU - STRIPE W/BLAU - STREIFEN W/BLAU

[110]

[111]



Ombrellone adatto all'uso privato e professionale, con buona resistenza alla ruggine, grazie all'uso del palo in **acciaio inox** ed alle bacchette zincate e verniciate. E' dotato d'inclinazione in metallo e come tessuto viene proposto il Dralon Acrilico, tessuto specifico outdoor.

Parasol adapte à l'utilisation privée et CHR, avec bonne résistance à la rouille, grâce à la structure avec **mât acier inox** plus baleines zinguées et vernies. Ce parasol a l'inclinaison en métal et le tissu proposé est le Dralon acrylique, un tissu spécifique pour outdoor.

Parasol suitable to private and commercial use, with good resistance to the rust, thanks to the **stainless steel pole** and to the galvanized and coated ribs. There is a metal tilt and a specific fabric for outdoor called Dralon acrylic is used.

Sonnenschirm geeignet für den privaten und Gastro Gebrauch, mit guter Rostbeständigkeit dank der **Edehstahlstock** and der galvanisierte und lackierte Schienen. Es gibt ein Metallknicker und als Stoff ein Dralon Acryl verwendet wird.



■ Bacchette zincate e verniciate
■ Baleines vernies et zinguées
■ Galvanized and coated ribs
■ Galvanisiert und lackiert
Streben



■ Palo acciaio inox con snodo metallo
■ Mât acier inox avec inclinaison métal
■ Stainless steel pole with metal tilt
■ Edelstahlgestell Stock mit Metallknicker



■ Prolungo in acciaio inox
■ Pique en acier inox
■ Stainless steel lower pole
■ Edelstahl Unterstock

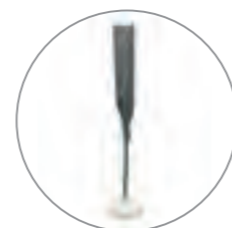

■ **Optional** consigliato:
Art. 920 fodera in Mytex
■ **Option** consigliée:
Art. 920 Housse en Mytex
■ **Recommended option:**
Art. 920 Mytex cover
■ **Empfohlene Option:**
Art. 920 Schutzhülle aus Mytex



■ **Optional:** Base in graniglia
■ **Option:** Pied en grès
■ **Option:** Grit base
■ **Option:** Betonständer

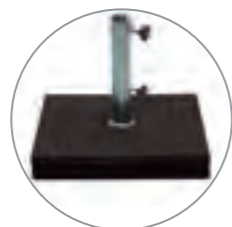

■ **Optional:** Base in cemento effetto legno
■ **Option:** Pied en béton finition bois
■ **Option:** Wooden effect concrete base
■ **Option:** Holzoptik Betonplatteständer

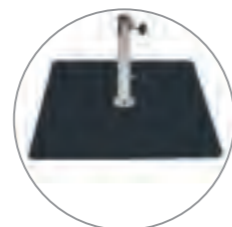

■ **Optional:** Base in metallo
■ **Option:** Plaque métallique
■ **Option:** Metal base
■ **Option:** Metallständer



■ **Optional:** Art. 352. Base da interrare in alluminio.
■ **Option:** Art. 352. Pied à enterrer en aluminium
■ **Option:** Art. 352. Ground anchor.
■ **Option:** Art. 352. Alu Sockel

Inox Ombrellone serie Utility con palo in acciaio inox

CARATTERISTICHE TECNICHE

TESSUTO: Dralon Acrilico 100% gr 190 mq, finitura Sun, protezione UV 20/50+ (dipende dal colore), resistenza colori 5-6 (dipende dal colore). L'ombrellone è dotato di laccio di chiusura.

STRUTTURA: pali mm 27/30 in acciaio inox, bacchette in acciaio zincate e verniciate, snodo metallo, apertura manuale, altezza regolabile, prolungo in acciaio inox.

Inox Parasol série Utility avec mât en acier inox

CARACTÉRISTIQUES TECHNIQUES

TISSU: Dralon Acrylique 100%, gr 190 mc, finition sun, protection UV 20/50+(selon couleur), résistance couleurs 5-6 (selon couleur). Le parasol a une bande de fermeture en dotation.

STRUCTURE: mâts 27/30 mm en acier inox, baleines en acier zinguées et vernies, inclinaison métal, ouverture manuelle, hauteur réglable, pique acier inox avec vis de serrage.

Inox Parasol Utility line with stainless steel pole

TECHNICAL FEATURES

FABRIC: Dralon Acrylic 100% gr 190 sm, sun finish, UV protection 20/50+(depending on colour), colour fastness 5-6 (depending on colour). The parasol has a tie-band for closing.

FRAME: stainless steel poles 27/30 mm, galvanised and coated steel ribs, metal tilt, manual opening, adjustable height, stainless steel lower pole with screw.

Inox Sonnenschirm der Utility-Serie mit Edelstahl Stock

TECHNISCHE EIGENSCHAFTEN

STOFF: Dralon Acryl 100%, gr 190 qm Sun beschichtect, UV Schutz 20/50+ (nach Farbe), Lichtechtheit 5/6 (nach Farbe). Der Sonnenschirm hat eine Schlingenverschluss.

GESTELL: Stock 27/30 mm aus Edelstahl, Streben aus galvanisiert und lackiert Stahl, Handöffnung, höhenverstellbar, Edelstahl Unterstock mit Schraube.



Le misure indicate non includono la base. Con base: + ca.5/10 cm.

Les mesures indiquées ne comprennent pas le pied. Avec pied: + ca.5/10 cm

These sizes don't include the base height. With base: + ca.5/10 cm

Diese Maßnahmen umfassen nicht den Fuß. Mit Fuß: + ca.5/10 cm

Kg Peso per base: min kg 20. Con peso maggiore avrete più stabilità e sicurezza. **Vedere basi pag. 154**

Kg Poids pour pied: min 20 kg. Avec plus de poids il y aura une majeure stabilité et sécurité. **Voir pieds à la page 154**

Kg Weight for base: min 20 kg. With higher weight, there are better stability and safety. **See bases on page 154**

Kg Gewicht für Ständer: min 20 kg. Mit höher Geewicht, es gibt besser stabilität und Sicherheit. **Ständer Seite 154**

Colori/Couleurs/Colours/Farben



Ecu
Ecu
Natural
Natur

Rosso
Rouge
Red
Rot

Rigia Bianca/Blu
Rayé Blanco/Blu
Stripes White/Blue
Streifen Weiss/Blau

SUPERALUX



Art. 102SA cm 100/8-D200

Art. 106RSA cm 240x150/4

Art. 106QSA cm 200x200/4



Art. 102SA RIGA B/TAUPE - RAYE B/TAUPE - STRIPE W/TAUPE - STREIFEN W/TAUPE

[114]



Art. 106QSA BIANCO/BLANC/WHITE/WEISS



Art. 106RSA ANTRACITE/ANTHRACITE/ANTHRAZIT

[115]

SUPERALUX



Ombrellone adatto all'uso privato e professionale, con buona resistenza alla ruggine, grazie all'uso del **palo in alluminio** ed alle bacchette zincate e verniciate. E' senza inclinazione per una maggiore resistenza. Come tessuto viene proposto il Dralon Acrilico, tessuto specifico outdoor..

Parasol adapte à l'utilisation privée et CHR, avec bonne résistance à la rouille, grâce à la structure avec **mât aluminium** et baleines zinguées et vernies. Ce parasol est sans inclinaison pour garantir une meilleure résistance. Le tissu proposé est Le Dralon acrylique, un tissu spécifique pour outdoor.

Parasol suitable to private and commercial use, with good resistance to the rust, thanks to the **aluminium pole** and to the galvanized and coated ribs. It's without tilt to guarantee more solidity. As fabric, we propose Dralon acrylic, very good for outdoor.

Sonnenschirm geeignet für den privaten und Gastro Gebrauch, mit guter Rostbeständigkeit dank der **Aluminium Stock** and der galvanized und lackierte Schienen. Es gibt keine Knicker, um eine höher Festigkeit zu garantieren. Als Stoff ein Dralon Acryl, sehr gut für outdoor, verwendet wird.



■ Struttura versione D 200
■ Structure version D 200
■ Frame size D 200
■ Gestell große D 200



■ Struttura versione quadrata e rettangolare
■ Pique en alu avec vis
■ Aluminium lower pole with screw
■ Aluminium Unterstock mit Schraube
■ Gestell quadrat und rechteckig Form



■ Prolungo in alluminio con vite
■ Pique en alu avec vis
■ Aluminium lower pole with screw
■ Aluminium Unterstock mit Schraube

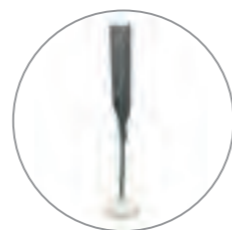

■ **Optional** consigliato: Art. 920 per D 200, Art. 921 per altre misure
■ **Option** conseillée: Art. 920 pour D 200, Art. 921 pour autres tailles
■ **Recommended option**: Art. 920 for D 200, Art. 921 for other sizes
■ **Empfohlene Option**: Art. 920 für D 200, Art. 921 für andere Größen



■ **Optional**: Base in graniglia
■ **Option**: Pied en grès
■ **Option**: Grit base
■ **Option**: Betonständer

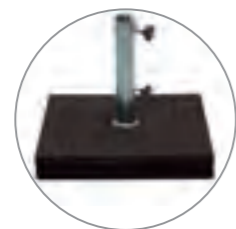

■ **Optional**: Base in cemento effetto legno
■ **Option**: Pied en béton finition bois
■ **Option**: Wooden effect concrete base
■ **Option**: Holzoptik Betonplatteständer



■ **Optional**: Base in metallo
■ **Option**: Plaque métallique
■ **Option**: Metal base
■ **Option**: Metallständer



■ **Optional**: Base in cemento ricoperta plastica
■ **Option**: Pied en béton couvert plastique
■ **Option**: Concrete base covered with plastic
■ **Option**: Betonständer mit Kunststoff

Superalux Ombrellone linea Utility con palo in alluminio

CARATTERISTICHE TECNICHE

TESSUTO: Dralon Acrilico 100% gr 190 mq, finitura Sun, protezione UV 20/50+ (dipende dal colore), resistenza colori 5-6 (dipende dal colore) per versione D 200.

PolyMa poliestere gr 210 mq, idrorepellente, antimuffa, protezione UV 50+, resistenza colori 6+, per versioni quadrata e rettangolare.

STRUTTURA: pali mm 35/40 in alluminio, senza snodo, apertura manuale, altezza regolabile, prolungo in alluminio con vite. Art. 102SA bacchette in acciaio zincate e verniciate, Art.106 bacchette paragon.

Superalux Parasol Série Utility avec mât en aluminium

CARACTÉRISTIQUES TECHNIQUES

TISSU: Dralon Acrylique 100%, gr 190 mc, finition sun, protection UV 20/50+ (selon couleur), résistance couleurs 5-6 (selon couleur) pour taille D 200.

PolyMa Polyester, gr 210 mc, hydrofuge, anti-moisissure, protection UV 50+, résistance couleurs 6+, pour tailles carrée et rectangulaire.

STRUCTURE: mâts 35/40 mm en alu, sans inclinaison, ouverture manuelle, hauteur réglable, pique aluminium avec vis de serrage. Art. 102SA baleines en acier zinguées et vernies, Art.106 baleines paragon.

Superalux Parasol Utility line with aluminium pole

TECHNICAL FEATURES

FABRIC: Dralon Acrylic 100% gr 190 sm, sun finish, UV protection 20/50+ (depending on colour), colour fastness 5-6 (depending on colour) for size D 200.

PolyMa Polyester gr 210 sm, water-repellent, mouldproof, UV protection 50+, colour fastness 6+, for square and rectangular shapes.

FRAME: Aluminium steel poles 35/40 mm, without tilt, manual opening, adjustable height, aluminium lower pole with screw. Art. 102SA galvanised and coated steel ribs, art. 106 paragon ribs.

Superalux Sonnenschirm der Utility-Serie mit Aluminium Stock

TECHNISCHE EIGENSCHAFTEN

STOFF: Dralon Acryl 100%, gr 190 qm Sun beschichtet, UV Schutz 20/50+ (es kommt aus die Farbe an), Lichtechtheit 5/6 (es kommt aus die Farbe an) für große D 200.

PolyMa Polyester gr 210 qm, Wasserabstoßend imprägniert, Verrottungsfest, UV Schutz 50+, Lichtechtheit 6+, für quadrat und rechteckig.

GESTELL: Stock 35/40 mm aus Aluminium, ohne Knicker, Handöffnung, höhenverstellbar, Aluminium Unterstock mit Schraube. Art.102SA Streben aus galvanisiert und lackiert Stahl, Art. 106 paragon Streben.



kg Peso per base: min kg 20 per D 200, min kg 30 per altre misure. Con peso maggiore avrete più stabilità e sicurezza.

Vedere basi pag. 154

kg Poids pour pied: min 20 kg pour taille D 200, min 30 pour autres tailles. Avec plus de poids il y aura une majeure stabilité et sécurité. **Voir pieds à la page 154**

kg Weight for base: min 20 kg for D 200, min 30 kg for other sizes. With higher weight, there are better stability and safety.

See bases on page 154

kg Gewicht für Ständer: min 20 kg for D 200, min 30 kg für andere Größen. Mit höher Gewicht, es gibt besser stabilität und Sicherheit. **Ständer Seite 154**

Colori/Couleurs/Colours/Farben Art 102SA



Ecu
Ecu
Natural
Natur

Taupe
Taupe
Taupe
Taupe

Colori speciali/Couleurs spéciales/Special colours/Sonderfarben Art. 102SA

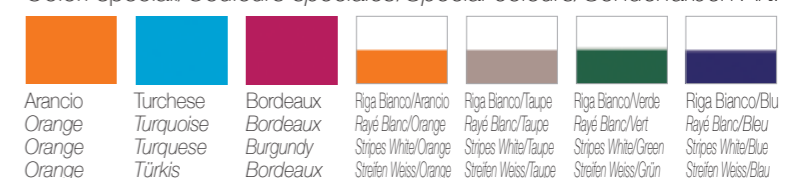

Arancio
Orange
Orange
Orange

Turchese
Turquoise
Turquoise
Türkis

Bordeaux
Bordeaux
Burgundy
Bordeaux

Riga Bianco/Arancio
Rayé Bianco/Orange
Stripes White/Orange
Streifen Weiss/Orange

Riga Bianco/Taupe
Rayé Bianco/Taupe
Stripes White/Taupe
Streifen Weiss/Taupe

Riga Bianco/Verde
Rayé Bianco/Vert
Stripes White/Green
Streifen Weiss/Grün

Riga Bianco/Blu
Rayé Bianco/Blau
Stripes White/Blue
Streifen Weiss/Blau

Colori/Couleurs/Colours/Farben Art 106QSA - Art. 106RSA



Bianco
Blanc
White
Weiss

Ecu
Ecu
Natural
Natur

Taupe
Taupe
Taupe
Taupe

Antracite
Anthracite
Anthracite
Anthrazit

ALUX



Art. 102K cm 100/8-D200



Art. 102K BLU/BLEU/BLUE/BLAU



- Palo alluminio con snodo metallo
- Mât alu avec inclinaison métal
- Aluminium pole with metal tilt
- Aluminium Stock mit Metallknicker

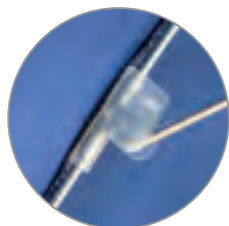

- Protezione bacchette
- Protection pour baleines
- Rib protection
- Schienenschutz



- Bacchette zincate ad uncino
- Baleines zinguées à crochet
- Hooked galvanised ribs
- Verzinkten Hackenstreben



- Aggancio palo superiore/inferiore
- Couplage mât supérieur/inferieur
- Locking upper/lower pole
- Verbindung Oberstock/Unterstock



- **Optional:** Base in graniglia
- **Option:** Pied en grès
- **Option:** Grit base
- **Option:** Betonständer

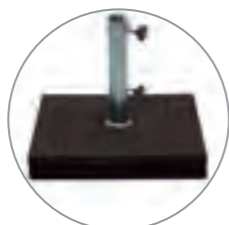

- **Optional:** Base in cemento effetto legno
- **Option:** Pied en béton finition bois
- **Option:** Wooden effect concrete base
- **Option:** Holzoptik Betonplatteständer



- **Optional:** Base in cemento ricoperta plastica
- **Option:** Pied en béton couvert plastique
- **Option:** Concrete base covered with plastic
- **Option:** Betonständer mit Kunststoff

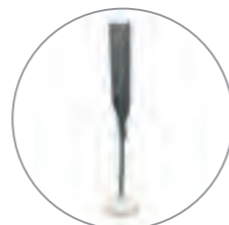

- **Optional consigliato:** Art. 920 fodera in Mytex
- **Option conseillée:** Art. 920 Housse en Mytex
- **Recommended option:** Art. 920 Mytex cover
- **Empfohlene Option:** Art. 920 Schutzhülle aus Mytex

Alux Ombrellone serie Utility con palo in alluminio

CARATTERISTICHE TECNICHE

TESSUTO: PolyMa poliestere gr 210 mc, idrorepellente, antimuffa, protezione UV 50+, resistenza colori 6+. L'ombrellone è dotato di laccio chiusura.

STRUTTURA: pali mm 33/37 in alluminio, bacchette in acciaio zincate ad uncino, snodo metallo, apertura manuale, altezza fissa.

Alux Parasol série Utility avec mât en aluminium

CARACTÉRISTIQUES TECHNIQUES

TISSU: PolyMa Polyester, gr 210 mc, hydrofuge, anti-moisissure, protection UV 50+, résistance couleurs 6+. Le parasol a une bande de fermeture en dotation.

STRUCTURE: mâts 33/37 mm en aluminium, baleines à crochet en acier zingué, inclinaison métal, ouverture manuelle, hauteur fixe.

Alux Parasol Utility line with aluminium pole

TECHNICAL FEATURES

FABRIC: PolyMa Polyester gr 210 sm, water-repellent, mouldproof, UV protection 50+, colour fastness 6+. The parasol has a tie-band for closing.

FRAME: alu poles 33/37 mm, galvanised hooked ribs, metal tilt, manual opening, fixed height.

Alux Sonnenschirm der Utility-Serie mit Aluminium Stock

TECHNISCHE EIGENSCHAFTEN

STOFF: PolyMa Polyester gr 210 qm, Wasserabstoßend imprägniert, Verrottungsfest, UV Schutz 50+, Lichtechtheit 6+. Der Sonnenschirm hat eine Schlingenverschluss.

GESTELL: Stock 33/37 mm aus Aluminium, Hackenstreben aus galvanisiert Stahl, Handöffnung, feste Höhe.

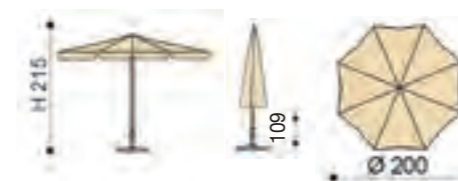

Le misure indicate non includono la base. Con base: + ca.5/10 cm.

Les mesures indiquées ne comprennent pas le pied. Avec pied: + ca.5/10 cm

These sizes don't include the base height. With base: + ca.5/10 cm

Diese Maßnahmen umfassen nicht den Fuß. Mit Fuß: + ca.5/10 cm

kg Peso per base: min kg 20. Con peso maggiore avrete più stabilità e sicurezza. **Vedere basi pag. 154**

kg Poids pour pied: min 20 kg. Avec plus de poids il y aura une majeure stabilité et sécurité. **Voir pieds à la page 154**

kg Weight for base: min 20 kg. With higher weight, there are better stability and safety. **See bases on page 154**

kg Gewicht für Ständer: min 20 kg. Mit höher Gewicht, es gibt besser stabilität und Sicherheit. **Ständer Seite 154**

Colori/Couleurs/Colours/Farben



Bianco
Blanc
White
Weiss

Ecrú
Ecrú
Natural
Natur

Giallo
Jaune
Yellow
Gelb

Arancio
Orange
Orange
Orange

Rosso
Rouge
Red
Rot

Verde
Vert
Green
Grün

Blu
Bleu
Blue
Blau

Taupe
Taupe
Taupe
Taupe

Antracite
Anthracite
Anthracite
Anthrazit

BORGO



Art. 12 cm 100/8-D200



Art. 12 GIALLO/JAUNE/YELLOW/GELB ARANCIO/ORANGE ROSSO/ROUGE/RED/ROT



- Struttura mm 22/25 - D 200
- Structure 22/25 mm - D 200
- Frame 22/25 mm - D 200
- Gestell 22/25 mm - D 200

Pour marché européen
For european market
Für den europäischen Markt



- Struttura mm 33/33 - D 200
- Structure 33/33 mm - D 200
- Frame 33/33 mm - D 200
- Gestell 33/33 mm - D 200

Telaio per mercato italiano



- Struttura mm 33/33 D 200
- Structure 33/33 mm D 200
- Frame 33/33 mm D 200
- Gestell 33 mm D 200

Telaio per mercato italiano

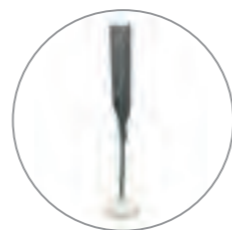

- **Optional** consigliato: Art. 920 per D 200
- **Option** conseillée: Art. 920 pour D 200
- **Recommended option**: Art. 920 for D 200
- **Empfohlene Option**: Art. 920 für D 200



- **Optional**: Base in graniglia
- **Option**: Pied en grès
- **Option**: Grit base
- **Option**: Betonständer

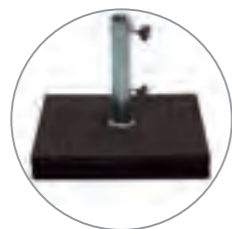

- **Optional**: Base in cemento effetto legno
- **Option**: Pied en béton finition bois
- **Option**: Wooden effect concrete base
- **Option**: Holzoptik Betonplatteständer

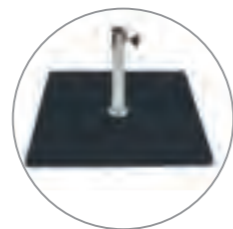

- **Optional**: Base in metallo calpestabile
- **Option**: Plaque métallique
- **Option**: Metal base
- **Option**: Metallständer



- **Optional**: Base in plastica
- **Option**: Pied en plastique
- **Option**: Plastic base
- **Option**: Fuß aus Kunststoff

Italy Borgo Ombrellone classico con poliestere PolyMa

CARATTERISTICHE TECNICHE

TESSUTO: Polyma poliestere gr 210 mq, idrorepellente, protezione UV50+, resistenza colori 6+.

STRUTTURA: pali mm 22/25 e bacchette in acciaio colore bianco, con snodo metallo, apertura manuale, altezza regolabile, prolungo con leva, oppure pali mm 33/33 in acciaio colore grigio o bianco, bacchette in acciaio verniciate bianche, con snodo nylon bianco, apertura manuale, altezza fissa, prolungo con leva.

France Borgo Parasol classique en polyester PolyMa

CARACTÉRISTIQUES TECHNIQUES

TISSU: PolyMa Polyester, gr 210 mc, hydrofuge, anti-moisissure, protection UV 50+, résistance couleurs 6+.

STRUCTURE: mâts 22/25 mm et baleines en acier verni blanc, inclinaison métal, ouverture manuelle, hauteur réglable, pique avec levier, ou mâts 33/33 mm en acier verni gris ou blanc, baleines en acier vernies blanches, inclinaison nylon blanc, ouverture manuelle, hauteur fixe, pique avec levier.

UK Borgo Classic parasol with PolyMa polyester

TECHNICAL FEATURES

FABRIC: PolyMa Polyester gr 210 sm, water-repellent, mouldproof, UV protection 50+, colour fastness 6+.

FRAME: white steel poles 22/25 mm and ribs, with metal tilt, manual opening, adjustable height, lower pole with clip, or grey or white steel poles 33/33 mm, white steel ribs, with white nylon tilt, manual opening, adjustable height, lower pole with clip.

Germany Borgo Klassischer Sonnenschirm mit PolyMa Polyester

TECHNISCHE EIGENSCHAFTEN

STOFF: PolyMa Polyester gr 210 qm, Wasserabstoßend imprägniert, Verrottungsfest, UV Schutz 50+, Lichtechtheit 6+.

GESTELL: Stocke 22/25 mm und Streben aus Stahl, Farbe Weiß, mit Metallknicker, Handöffnung, höhenverstellbar, Unterstock mit Hebel, oder Stahlstocke 33/33 mm, Farbe Grau oder Weiß, Weiße Stahlstreben und Knicker, Handöffnung, feste Höhe, Unterstock mit Hebel.



Le misure indicate non includono la base. Con base: + ca.5/10 cm.

Les mesures indiquées ne comprennent pas le pied. Avec pied: + ca.5/10 cm

These sizes don't include the base height. With base: + ca.5/10 cm

Diese Maßnahmen umfassen nicht den Fuß. Mit Fuß: + ca.5/10 cm

Kg Peso per base: min kg 15. Con peso maggiore avrete più stabilità e sicurezza. **Vedere basi pag. 154**

Kg Poids pour pied: min 15 kg. Avec plus de poids il y aura une majeure stabilité et sécurité. **Voir pieds à la page 154**

Kg Weight for base: min 15 kg. With higher weight, there are better stability and safety. **See bases on page 154**

Kg Gewicht für Ständer: min 15 kg. Mit höher Gewicht, es gibt besser stabilität und Sicherheit. **Ständer Seite 154**

Colori/Couleurs/Colours/Farben



MARE



Art. 72 cm 100/8-D200



Art. 72 RIGA B/ARANCIO - RAYE B/ORANGE - STRIPE W/ORANGE - STREIFEN W/ORANGE (33/33)



Art. 72 RIGA B/ARANCIO - RAYE B/ORANGE - STRIPE W/ORANGE - STREIFEN W/ORANGE (22/25)

|122|

Art. 75/6 cm 125/6-D250



Art. 75/6 TERRACOTTA/TERREQUITE

|123|



Ombrellone adatto all'uso privato e professionale, con tessuto Dralon acrilico e telaio acciaio disponibile per la versione D 200, sia con pali mm 22/25 altezza regolabile che mm 33/33 altezza fissa.

Parasol adapte à l'utilisation privée et CHR, avec tissu Dralon acrylique et structure acier disponible pour la taille D 200 dans deux versions 22/25 mm hauteur réglable et 33/33 mm hauteur fixe.

Parasol suitable to private and commercial use, with Dralon Acrylic fabric and steel frame available both in the version 22/25 mm adjustable height, and in the 33/33 with fixed height.

Sonnenschirm geeignet für den privaten und Gastro Gebrauch, mit Dralon Acryl Stoff und Stahgestell erhältlich mit Gestell 22/25 mm höhenverstellbar und 33/33 mm feste Höhe.



■ Struttura mm 22/25 - D 200
■ Structure 22/25 mm - D 200
■ Frame 22/25 mm - D 200
■ Gestell 22/25 mm - D 200

Pour marché européen
For european market
Für den europäischen Markt



■ Struttura mm 33/33 D 200
■ Structure 33/33 mm D 200
■ Frame 33/33 mm D 200
■ Gestell 33 mm D 200

Telaio per mercato italiano

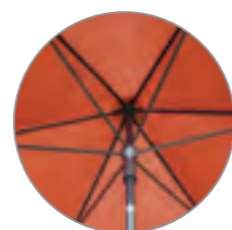

■ Struttura versione D 250
■ Structure version D 250
■ Frame size D 250
■ Gestell große D 250

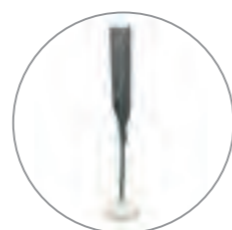

■ **Optional** consigliato: Art. 920 per D 200, Art. 921 per D 250
■ **Option** conseillée: Art. 920 pour D 200, Art. 921 pour D 250
■ **Recommended option:** Art. 920 for D 200, Art. 921 for D 250
■ **Empfohlene Option:** Art. 920 für D 200, Art. 921 für D 250



■ **Optional:** Base in graniglia
■ **Option:** Pied en grès
■ **Option:** Grit base
■ **Option:** Betonständer

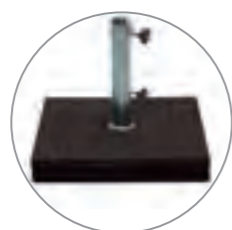

■ **Optional:** Base in cemento effetto legno
■ **Option:** Pied en béton finition bois
■ **Option:** Wooden effect concrete base
■ **Option:** Holzoptik Betonplatteständer



■ **Optional:** Art. 352. Base da interrare in alluminio.
■ **Option:** Art. 352. Pied à enterrer en aluminium
■ **Option:** Art. 352. Alu ground anchor.
■ **Option:** Art. 352. Alu Sockel



■ **Optional:** Base in plastica (solo D 200)
■ **Option:** Pied en plastique (seulement D 200)
■ **Option:** Fuß aus Kunststoff (nur D 200)

Mare Ombrellone classico top di gamma

CARATTERISTICHE TECNICHE

TESSUTO: Dralon Acrilico gr 190 mq, finitura Sun, protezione UV 20/50+ (dipende dal colore), resistenza colori 5-6 (dipende dal colore) per versione D 200.

PolyMa poliestere gr 210 mq, idrorepellente, antimuffa, protezione UV 50+, resistenza colori 6+, per versione D 250.

STRUTTURA: D 200 - pali **22/25** mm e bacchette in acciaio colore bianco, con snodo metallo, apertura manuale, altezza regolabile, prolungo con leva.

D 200 - pali **33/33** mm in acciaio colore bianco, bacchette in acciaio verniciate bianche, con snodo nylon bianco, apertura manuale, altezza fissa, prolungo con leva.

D 250 - pali **27/30** mm in acciaio colore grafite, bacchette paragon, con snodo metallo, apertura manuale, altezza regolabile, prolungo zincato con vite.

Mare Parasol classique haute de gamme

CARACTÉRISTIQUES TECHNIQUES

TISSU: Dralon Acrylique gr 190 mc, finition sun, protection UV 20/50+(selon couleur), résistance couleurs 5-6 (selon couleur) taille D 200.

PolyMa Polyester, gr 210 mc, hydrofuge, anti-moisissure, protection UV 50+, résistance couleurs 6+, pour tailles D 250.

STRUCTURE: D 200 mâts **22/25** mm et baleines en acier verni blanc, inclinaison métal, ouverture manuelle, hauteur réglable, pique avec levier.

D 200 - mâts **33/33** mm en acier verni blanc, baleines en acier vernies blanches, inclinaison nylon blanc, ouverture manuelle, hauteur fixe, pique avec levier.

D 250 mâts **27/30** mm en acier verni graphite, baleines paragon, inclinaison métal, ouverture manuelle, hauteur réglable, pique zinguée avec vis réglable, pique acier inox avec vis de serrage.

Mare Classic high quality parasol

TECHNICAL FEATURES

FABRIC: Dralon Acrylic gr 190 sm, sun finish, UV protection 20/50+(depending on colour), colour fastness 5-6 (depending on colour) – size D 200.

PolyMa Polyester gr 210 sm, water-repellent, mouldproof, UV protection 50+, colour fastness 6+, for square D 250.

FRAME: D200 - White steel coated poles **22/25** mm and ribs, with metal tilt, manual opening, adjustable height, lower pole with clip

D 200 - White steel poles **33/33** mm, white steel ribs, with white nylon tilt, manual opening, adjustable height, lower pole with clip

D 250 - Graphite steel poles **27/30** mm, paragon ribs, with tilt, manual opening, adjustable height, galvanized lower pole with screw

Mare Klassischer Sonnenschirm höher Qualität

TECHNISCHE EIGENSCHAFTEN

STOFF: Dralon Acryl gr 190 qm Sun beschichtect, UV Schutz 20/50+ (nach Farbe), Lichtechtheit 5/6 (nach Farbe) – große D 200.

PolyMa Polyester gr 210 qm, Wasserabstoßend imprägniert, Verrottungsfest, UV Schutz 50+, Lichtechtheit 6+, für D 250.

GESTELL: D200 - Weiße Stocke **22/25** mm, und Schienen aus Stahl, mit Metallknicker, Handöffnung, höhenverstellbar, Unterstock mit Hebel.

D 200 - Weiße StahlStocke **33/33** mm, Weiße Stahlstreben und Knicker, Handöffnung, feste Höhe, Unterstock mit Hebel.

D 250 - Graphit StahlStocke **27/30** mm, Paragon Stahlstreben, mit Metallknicker, Handöffnung, höhenverstellbar, verzinkter

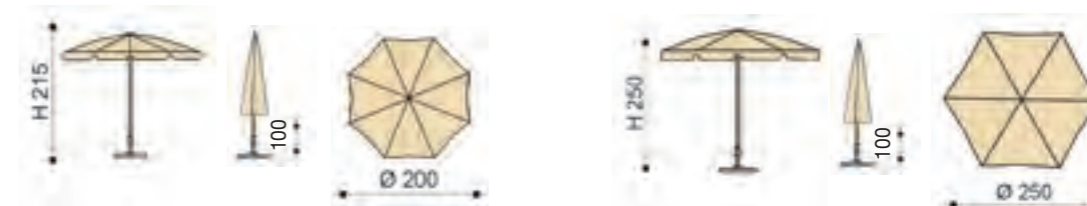

kg Peso per base: min kg 15 x D 200, min kg 30 per D 250. Con peso maggiore avrete più stabilità e sicurezza. **Vedere basi pag. 154**

kg Poids pour pied: min 15 kg pour D 200, min 30 kg pour D 250. Avec plus de poids il y aura une majeure stabilité et sécurité. **Voir pieds à la page 154**

kg Weight for base: min 15 kg for D 200, min 30 kg for D 250. With higher weight, there are better stability and safety. **See bases on page 154**

kg Gewicht für Ständer: min 15 kg für D 200, min 30 kg für D 250. Mit höher Gewicht, es gibt besser stabilität und Sicherheit. **Ständer Seite 154**

Colori/Couleurs/Colours/Farben Art. 75/6

P	P	T	P
Ecrú	Taupe	Terracotta	Verde
Ecrú	Taupe	Terrecuite	Vert
Natural	Taupe	Terracotta	Green
Natur	Taupe	Terracotta	Grün

Disegni/Design/Dessins/Designs Art. 72/22-72

Bianco/Arancio	Bianco/Taupe	Bianco/Verde	Bianco/Blu
Blanc/Orange	Blanc/Taupe	Blanc/Vert	Blanc/Bleu
White/Orange	White/Taupe	White/Green	White/Blue
Weiss/Orange	Weiss/Taupe	Weiss/Grün	Weiss/Blau

KENYA - TULUM

 **KENIA**
Art. 6 cm 100/8-D200

 **TULUM**
Art. 7 cm 100/8-D200



Art. 6 GRIGIO/GRIS/GREY/GRAU



Art. 7 BIA/AZZURRO/BLU - BLANC/AZUR/BLEU - WHITE/SKY/BLUE - WEISS/HELLBLAU/BLAU

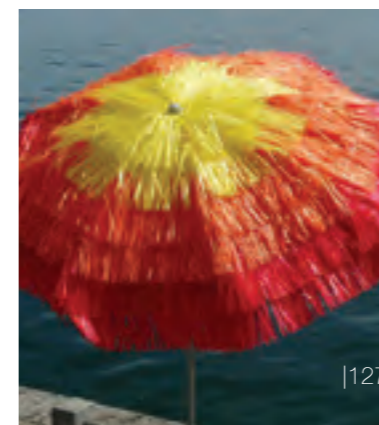

KENIA-TULUM



KENYA: ombrellone ricoperto con rafia tinta unita in vasta gamma di colori e telaio acciaio mm 33/33 colore grigio.
TULUM: ombrellone ricoperto con rafia a 3 colori in degradé e telaio acciaio mm 33/33 colore grigio.

KENYA: parasol couvert avec raphia en teinte unie dans une vaste gamme de couleurs et structure acier 33/33 mm couleur gris.
TULUM: parasol couvert avec raphia en 3 couleurs dégradées et structure acier 33/33 mm couleur gris.

KENYA: parasol covered with solid straw in a wide range of colours and grey steel frame 33/33 mm.
TULUM: parasol covered with 3 dégradé colours and grey steel frame 33/33 mm

KENYA: Sonnenschirm mit Unifarbe Bast in vielen Farben und graues lackiert Stahlgestell 33/33 mm.
TULUM: Sonnenschirm mit 3 dégradé Farben und graues lackiert Stahlgestell 33/33 mm.



■ Struttura mm 33/33 - D 200
 ■ Structure 33/33 mm - D 200
 ■ Frame 33/33 mm - D 200
 ■ Gestell 33/33 mm - D 200

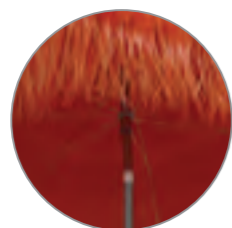

■ Art. 6 Kenia
 ■ Art. 6 Kenia
 ■ Art. 6 Kenia
 ■ Art. 6 Kenia



■ Art. 7 Tulum
 ■ Art. 7 Tulum
 ■ Art. 7 Tulum
 ■ Art. 7 Tulum

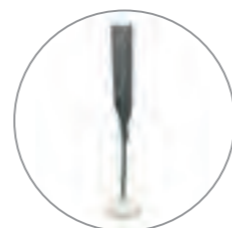

■ **Optional** consigliato:
 Art. 920R fodera in Mytex
 ■ **Option** conseillée:
 Art. 920R Housse en Mytex
 ■ **Recommended option:**
 Art. 920R Mytex cover
 ■ **Empfohlene Option:**
 Art. 920R Schutzhülle aus Mytex



■ **Optional:** Base in graniglia
 ■ **Option:** Pied en grès
 ■ **Option:** Grit base
 ■ **Option:** Betonständer

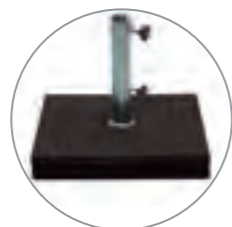

■ **Optional:** Base in cemento effetto legno
 ■ **Option:** Pied en béton finition bois
 ■ **Option:** Wooden effect concrete base
 ■ **Option:** Holzoptik Betonplatteständer



■ **Optional:** Art. 352. Base da interrare in alluminio.
 ■ **Option:** Art. 352. Pied à enterrer en aluminium
 ■ **Option:** Art. 352. Alu ground anchor.
 ■ **Option:** Art. 352. Alu Sockel



■ **Optional:** Base in plastica
 ■ **Option:** Pied en plastique
 ■ **Option:** Plastic base
 ■ **Option:** Fuß aus Kunststoff

Kenia-Tulum

Kenya ombrellone classico ricoperto rafia tinta unita
 Tulum ombrellone classico ricoperto rafia a 3 colori degradé

CARATTERISTICHE TECNICHE

TESSUTO: tnt ricoperto rafia, resistenza colori 6+.

STRUTTURA: pali mm 33/33 in acciaio colore grigio, bacchette in acciaio verniciate bianche, con snodo nylon bianco, apertura manuale, altezza fissa, prolungo con leva (struttura bianca con rafia bianca).

Kenia-Tulum

Kenya parasol classique couvert avec raphia teinte unie
 Tulum parasol classique couvert avec raphia en 3 couleurs

CARACTÉRISTIQUES TECHNIQUES

TISSU: tnt couvert avec raphia, résistance couleurs 6+.

STRUCTURE: mâts 33/33 mm en acier verni gris, baleines en acier vernies blanches, inclinaison nylon blanc, ouverture manuelle, hauteur fixe, pique avec levier (structure blanche avec raphia blanche).

Kenia-Tulum

Kenya classic parasol covered with solid straw
 Tulum classic parasol covered with 3 dégradé raphia colours

TECHNICAL FEATURES

FABRIC: Tnt covered with straw, colour fastness 6+.

FRAME: grey steel poles 33/33 mm, white steel ribs, with white nylon tilt, manual opening, adjustable height, lower pole with clip (white frame with white straw)

Kenya-Tulum

Kenya Uni Bastschirm
 Tulum Bastschirm mit 3 Farben Degrade Effekt

TECHNISCHE EIGENSCHAFTEN

STOFF: Tnt mit Bast, Lichtechtheit 6+.

GESTELL: grauen Stahlstocke 33/33 mm, Weißen Stahlstreben, mit weiss Nylon Knicker, Handöffnung, feste Höhe, Unterstock mit Hebel (weißes Gestell mit weißem Bast).



Le misure indicate non includono la base. Con base: + ca.5/10 cm.

Les mesures indiquées ne comprennent pas le pied. Avec pied: + ca.5/10 cm

These sizes don't include the base height. With base: + ca.5/10 cm

Diese Maßnahmen umfassen nicht den Fuß. Mit Fuß: + ca.5/10 cm

Kg Peso per base: min kg 15. Con peso maggiore avrete più stabilità e sicurezza. **Vedere basi pag. 154**

Kg Poids pour pied: min 15 kg. Avec plus de poids il y aura une majeure stabilité et sécurité. **Voir pieds à la page pag 154**

Kg Weight for base: min 15 kg. With higher weight, there are better stability and safety. **See bases on page 154**

Kg Gewicht für Ständer: min 15 kg. Mit höher Gewicht, es gibt besser stabilität und Sicherheit. **Ständer Seite 154**

Colori/Couleurs/Colours/Farben Art. 6-7



Nero	Argento	Bianco*	Ecru	Giallo	Arancio	Rosso	Fucsia	Blu	Verde	Lime
Noir	Argent	Blanc*	Ecru	Jaune	Orange	Rouge	Fuchsia	Bleu	Vert	Anis
Black	Silver	White*	Natural	Yellow	Orange	Red	Fuchsia	Blue	Green	Lime
Schwarz	Silver	Weiss*	Natur	Gelb	Orange	Rot	Fuchsia	Blau	Grün	Lime

NOVARA



Art. 111 cm 90/8-D180-22/25

Art. 112 cm 100/8-D200

Art. 114 cm 120/10-D240-33/33



Art. 112 VERDE/VERT/GREEN/GRÜN

- Ombrellone adatto all'uso privato, con tessuto poliestere unito e telaio acciaio mm 22/25 e 33/33 in colore bianco.
- Parasol adapté à l'utilisation privée, avec tissu polyester unie et structure acier en 22/25 et 33/33 en couleur blanc.
- Parasol suitable to private use, with solid polyester fabric and steel frame available in 22/25 and 33/33 white colour.
- Sonnenschirm geeignet für den privaten und Gebrauch, mit uni Polyester Stoff und Stahgestell 22/25 und 33/33, Weiss.



- Struttura mm 22/25 D 180-200
- Structure 22/25 mm D 180-200
- Frame 22/25 mm D 180-200
- Gestell 22/25 mm D180-200

Pour marché européen
For european market
Für den europäischen Markt



- Struttura mm 33/33 D 200-240
- Structure 33/33 mm D 200-240
- Frame 33/33 mm D 200-240
- Gestell 33 mm D 200-240

Telaio per mercato italiano

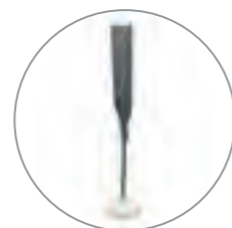

- Optional** consigliato: Art. 920 per D 180-200, Art. 921 per D 240
- Option** conseillée: Art. 920 pour D 180-200, Art. 921 pour D 240
- Recommended option:** Art. 920 for D 180-200, Art. 921 for D 240
- Empfohlene Option:** Art. 920 für D 180-200, Art. 921 für D 240



- Optional:** Base in graniglia
- Option:** Pied en grès
- Option:** Grit base
- Option:** Betonständer

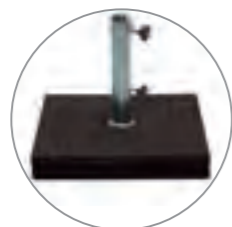

- Optional:** Base in cemento effetto legno
- Option:** Pied en béton finition bois
- Option:** Wooden effect concrete base
- Option:** Holzoptik Betonplatteständer



- Optional:** Base in plastica (solo D 180-200)
- Option:** Pied en plastique (seulement D 180-200)
- Option:** Plastic base (just D 180-200)
- Option:** Fuß aus Kunststoff (nur D 180-200)

Novara Ombrellone classico in poliestere

CARATTERISTICHE TECNICHE

TESSUTO: poliestere 100% gr 140 mq, idrorepellente, resistenza colori 4-5 (dipende dal colore).

STRUTTURA: D 180-200 (versione -22) - pali mm 22/25 e bacchette in acciaio bianche, con snodo metallo, apertura manuale, altezza regolabile, prolungo con leva.

D 200-240 - pali mm 33/33 e bacchette in acciaio bianche, con snodo nylon, apertura manuale, altezza fissa, prolungo con leva.

Novara Parasol classique en polyester

CARACTÉRISTIQUES TECHNIQUES

TISSU: polyester 100%, gr 140 mc, hydrofuge, résistance couleurs 4-5 (selon couleur).

STRUCTURE: D 180-200 (version -22) - mâts 22/25 mm et baleines en acier verni blanc, inclinaison métal, ouverture manuelle, hauteur réglable, pique avec levier.

D 200-240 - mâts 33/33 mm et baleines en acier verni blanc, inclinaison nylon, ouverture manuelle, hauteur fixe, pique avec levier

Novara Classic polyester parasol

TECHNICAL FEATURES

FABRIC: polyester 100%, gr 140 sm, water-repellent, colour fastness 4-5.

FRAME: D 180-200 (version -22) - White coated steel pole 22/25 mm and ribs, metal tilt, manual opening, adjustable height, lower pole with clip.

D 200-240 - White coated steel pole 33/33 mm and ribs, with nylon tilt, manual opening, adjustable height, lower pole with clip

Novara Klassik Sonnenschirm mit Polyester Stoff

TECHNISCHE EIGENSCHAFTEN

STOFF: Polyester 100%, gr 140 qm wasserabstoßend imprägniert, Lichtechtheit 4/5 (nach Farbe).

GESTELL: D 180-200 (version -22) - Weiße Stöcke 22/25 mm und Schienen aus Stahl, mit Metallknicker, Handöffnung, höhenverstellbar, Unterstock mit Hebel.

D 200-240 - Weiße Stocke 33/33 mm, und Schienen aus Stahl, mit Nylon Knicker, Handöffnung, feste Höhe, Unterstock mit Hebel.

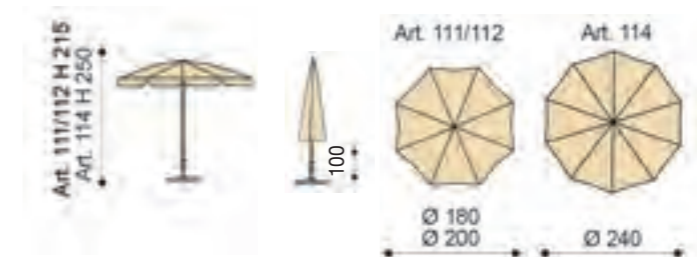

Le misure indicate non includono la base. Con base: + ca.5/10 cm.

Les mesures indiquées ne comprennent pas le pied. Avec pied: + ca.5/10 cm

These sizes don't include the base height. With base: + ca.5/10 cm

Diese Maßnahmen umfassen nicht den Fuß. Mit Fuß: + ca.5/10 cm

Peso per base: min kg 15 x D 180-200, min kg 25 per D 240. Con peso maggiore avrete più stabilità e sicurezza. **Vedere basi pag. 154**

Poids pour pied: min 15 kg pour D 180-200, min 25 kg pour D 240. Avec plus de poids il y aura une majeure stabilité et sécurité. **Voir pieds à la page 154**

Weight for base: min 15 kg for D 180-200, min 25 kg for D 240. With higher weight, there are better stability and safety. **See bases on page 154**

Gewicht für Ständer: min 15 kg für D 180-200, min 25 kg für D 240. Mit höher Gewicht, es gibt besser stabilität und Sicherheit. **Ständer Seite 154**

Colori/Couleurs/Colours/Farben Art 111



Ecu
Ecu
Natural
Natur

Art 112



Ecu
Ecu
Natural
Natur



Gris
Gris
Grey
Gru



Terracotta
Terracotta
Terracotta
Terracotta



Blu
Bleu
Blue
Blau



Verde
Vert
Green
Grün



Menta
Menthe
Mint
Minze



Ecu
Ecu
Natural
Natur



Gris
Gris
Grey
Gru

NOVARA



Art. 113Q cm 155x155/4
Art. 113R cm 185x125/4

Art. 114R cm 210x130/4



Art. 113Q GRIGIO/GRIS/GREY/GRAU

|132|



Art. 113Q GRIGIO/GRIS/GREY/GRAU (22/25)

|133|



Art 114R ECRU/NATURAL/NATUR

■ ■ Ombrellone adatto all'uso privato e professionale leggero, con tessuto poliestere unito e telaio acciaio in varie combinazioni: mm 22/25 e 27/30 sia in colore bianco che grafite.

■ ■ Parasol adapte à l'utilisation privée et CHR légère, avec tissu polyester unie et structure acier en plusieurs combinaisons: 22/25 et 27/30 en couleur blanc et graphite.

■ ■ Parasol suitable to private and light commercial use, with solid polyester fabric and steel frame available both in the version 22/25 and 27/30 mm in white and graphite colour.

■ ■ Sonnenschirm geeignet für den privaten und leicht Gastro Gebrauch, mit uni Polyester Stoff und Stahgestell 22/25 und 27/30 beide Weiss und Graphit Farbe.

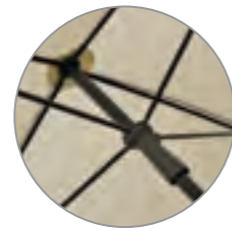

■ Struttura mm 22/25 grafite (Art 113Q-R)
■ Structure 22/25 mm graphite (Art 113Q-R)
■ Frame 22/25 mm graphite (Art 113Q-R)
■ Gestell 22/25 mm Graphit (Art 113Q-R)

■ Struttura mm 22/25 bianca (Art 113Q-R)
■ Structure 22/25 mm blanche (Art 113Q-R)
■ White frame 22/25 mm (Art 113Q-R)
■ Weisses Gestell 22/25 mm (Art 113Q-R)

■ Struttura mm 27/30 grafite (Art 114R)
■ Structure 27/30 mm graphite (Art 114R)
■ Frame 27/30 mm graphite (Art 114R)
■ Gestell 27/30 mm Graphit (Art 114R)

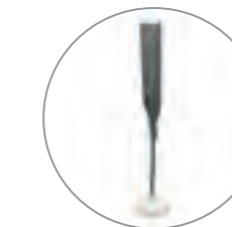
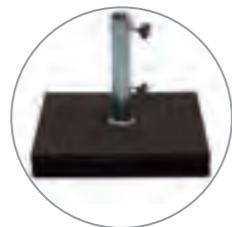

■ **Optional:** Base in graniglia
■ **Option:** Pied en grès
■ **Option:** Grit base
■ **Option:** Betonständer

■ **Optional:** Base in cemento effetto legno
■ **Option:** Pied en béton finition bois
■ **Option:** Wooden effect concrete base
■ **Option:** Holzoptik Betonplatteständer

■ **Optional consigliato:** Art. 921
■ **Option conseillée:** Art. 921
■ **Recommended option:** Art. 921
■ **Empfohlene Option:** Art. 921

■ ■ Novara Ombrellone classico in poliestere

CARATTERISTICHE TECNICHE

TESSUTO: poliestere 100% gr 140 mq, idrorepellente, resistenza colori 4-5 (dipende dal colore).

STRUTTURA: cm 155x155-185x125 – pali mm 22/25 in acciaio, bacchette paragon, colore bianco o grafite, con snodo metallo, apertura manuale, altezza regolabile, prolungo con leva. Cm 210x130 pali in acciaio, bacchette paragon, snodo metallo, apertura manuale, prolungo zincato e verniciato con vite, struttura colore grafite.

■ ■ Novara Parasol classique en polyester

CARACTÉRISTIQUES TECHNIQUES

TISSU: polyester 100%, gr 140 mc, hydrofuge, résistance couleurs 4-5 (selon couleur).

STRUCTURE: cm 155x155-185x125 – mâts 22/25 mm en acier, baleines paragon, couleur blanc ou graphite, inclinaison métal, ouverture manuelle, hauteur réglable, pique avec levier.

Cm 210x130 mâts en acier, baleines paragon, inclinaison métal, ouverture manuelle, hauteur réglable, pique zinguée avec vis structure couleur graphite.

■ ■ Novara Classic polyester parasol

TECHNICAL FEATURES

FABRIC: polyester 100%, gr 140 sm, water-repellent, colour fastness 4-5.

FRAME: cm 155x155-185x125: steel poles 22/25 mm, paragon ribs, metal tilt colour white or graphite, manual opening, adjustable height, lower pole with clip. Cm 210x130 steel poles 27/30 mm, paragon ribs, with tilt, manual opening, adjustable height, galvanized lower pole with screw, graphite colour frame.

■ ■ Novara Klassik Sonnenschirm mit Polyester Stoff

TECHNISCHE EIGENSCHAFTEN

STOFF: Polyester 100%, gr 140 qm wasserabstoßend impräginert, Lichtechtheit 4/5 (nach Farbe).

GESTELL: cm 155x155-185x125 – Stahlstöcke 22/25 mm, Paragonstreben, Farbe Weiß oder Graphit, mit Metallknicker, Handöffnung, höhenverstellbar, Unterstock mit Hebel.

Cm 210x130 Stahlstöcke, Paragon Stahlstreben, mit Metallknicker, Handöffnung, höhenverstellbar, verzinkter Unterstock mit Hebel.

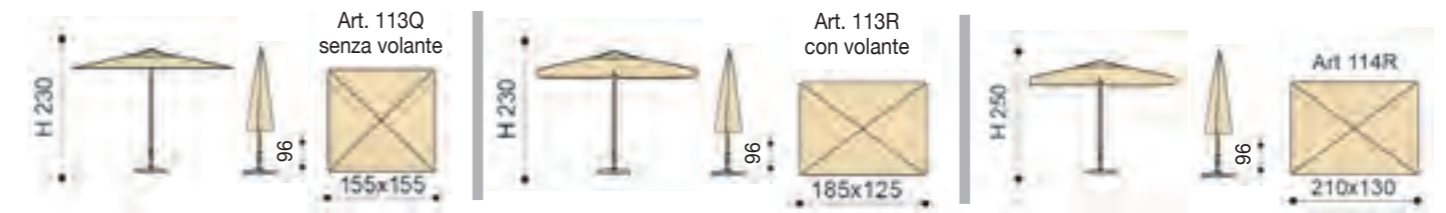

Le misure indicate non includono la base. Con base: + ca.5/10 cm.

Les mesures indiquées ne comprennent pas le pied. Avec pied: + ca.5/10 cm

These sizes don't include the base height. With base: + ca.5/10 cm

Diese Maßnahmen umfassen nicht den Fuß. Mit Fuß: + ca.5/10 cm

kg Peso per base: min kg 20. Con peso maggiore avrete più stabilità e sicurezza. **Vedere basi pag. 154**

kg Poids pour pied: min 20 kg. Avec plus de poids il y aura une majeure stabilité et sécurité. **Voir pieds à la page 154**

kg Weight for base: min 20 kg. With higher weight, there are better stability and safety. **See bases on page 154**

kg Gewicht für Ständer: min 20 kg. Mit höher Gewicht, es gibt besser stabilität und Sicherheit. **Ständer Seite 154**

Colori/Couleurs/Colours/Farben Art. 114R



Ecrú
Ecrú
Natural
Natur

Verde
Vert
Green
Grün

Grigio
Gris
Grey
Gru

Colori/Couleurs/Colours/Farben Art 113Q-113R



Ecrú
Ecrú
Natural
Natur

Verde
Vert
Green
Grün

Blu
Bleu
Blue
Blau

Grigio
Gris
Grey
Gru

VENEZIA



Art. 181 cm 100/8-D200



Art. 181 GIALLO/JAUNE/YELLOW/GELB

[136]

Art. 181A cm 100/8-D200

Art. 182A cm 115/8-D230



Art. 181A ECRU/TAUPE - NATURAL/TAUPE - NATUR/TAUPE



Art. 182A TAUPE/ECRU - TAUPE/NATURAL - TAUPE/NATUR

[137]

VENEZIA



Art 181A VERDE/VERT/GREEN/GRÜN

Ombrellone adatto all'uso privato e professionale leggero, con tessuto cotone duplex, disponibile con telaio palo acciaio o palo alluminio.

Parasol adapté à l'utilisation privé et CHR léger, avec tissu coton duplex, disponible avec structure mât acier ou aluminium.

Parasol suitable to private and light commercial use, with duplex cotton fabric available with and steel or aluminium pole.

Sonnenschirm geeignet für den privaten und leicht Gastro Gebrauch, mit duplex Baumwolle Stoff und Gestell mit Stahl oder Alu Stock.



- Struttura mm 22/25 - D 200
- Structure 22/25 mm - D 200
- Frame 22/25 mm - D 200
- Gestell 22/25 mm - D 200

Pour marché européen
For european market
Für den europäischen Markt



- Struttura mm 33/33 D 200
- Structure 33/33 mm D 200
- Frame 33/33 mm D 200
- Gestell 33 mm D 200

Telaio per mercato italiano

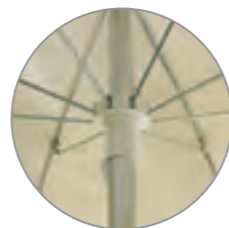

- Struttura 33/37 mm D 200-230
- Structure 33/37 mm D 200-230
- Frame 33/37 mm D 200-230
- Gestell 33/37 mm D 200-230



- **Optional** consigliato:
Art. 920 fodera in Mytex
- **Option** conseillée:
Art. 920 Housse en Mytex
- **Recommended option**:
Art. 920 Mytex cover
- **Empfohlene Option**:
Art. 920 Schutzülle aus Mytex



- **Optional**: Base in graniglia
- **Option**: Pied en grès
- **Option**: Grit base
- **Option**: Betonständer

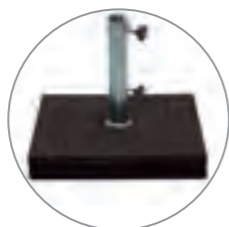

- **Optional**: Base in cemento effetto legno
- **Option**: Pied en béton finition bois
- **Option**: Wooden effect concrete base
- **Option**: Holzoptik Betonplatteständer

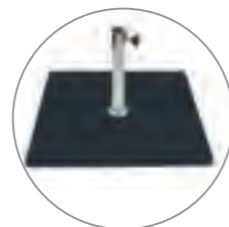

- **Optional**: Base in metallo calpestabile
- **Option**: Plaque métallique
- **Option**: Metal base
- **Option**: Metallständer



- **Optional**: Base in plastica (solo palo acciaio)
- **Option**: Pied en plastique (seulement mât acier)
- **Option**: Plastic base (just steel pole)
- **Option**: Fuß aus Kunststoff (nur Stahlstock)

Venezia Ombrellone classico in cotone duplex

CARATTERISTICHE TECNICHE

TESSUTO: cotone 100% gr 200 mq, resistenza colori 5.

STRUTTURA: D 200 (versione 22) – pali mm 22/25 e bacchette in acciaio verniciate bianche, con snodo metallo, apertura manuale, altezza regolabile, prolungo con leva.

D 200 – pali mm 33/33 in acciaio colore bianco, bacchette in acciaio verniciate bianche, con snodo nylon, apertura manuale, altezza fissa, prolungo con leva.

D200, D230 – pali mm 33/37 in alluminio, bacchette ad uncino in acciaio zincate, snodo metallo, apertura manuale, altezza fissa.

Venezia Parasol classique en coton duplex

CARACTÉRISTIQUES TECHNIQUES

TISSU: coton 100%, gr 200 mc, résistance couleurs 5.

STRUCTURE: D 200 (version -22) – mâts 22/25 mm et baleines en acier verni blanc, inclinaison métal, ouverture manuelle, hauteur réglable, pique avec levier.

D 200 - mâts 33/33 mm en acier verni blanc, baleines en acier vernies blanches, inclinaison nylon, ouverture manuelle, hauteur fixe, pique avec levier.

D200, D230 – mâts 33/37 mm en aluminium, baleines à crochet en acier zingué, inclinaison métal, ouverture manuelle, hauteur fixe.

Venezia Classic duplex cotton parasol

TECHNICAL FEATURES

FABRIC: cotton 100%, gr 200 sm, colour fastness 5.

FRAME: D 200 (version -22) - white powder coated poles 22/25 mm and ribs, metal tilt, manual opening, adjustable height, lower pole with clip.

D 200 – white steel poles 33/33 mm, white steel ribs, with nylon tilt, manual opening, adjustable height, lower pole with clip.

D200, D230 – alu poles 33/37 mm, galvanised hooked ribs, metal tilt, manual opening, fixed height.

Venezia Klassic Sonnenschirm mit duplex Baumwolle

TECHNISCHE EIGENSCHAFTEN

STOFF: Baumwolle 100%, gr 200 qm, Lichtechtheit 5.

GESTELL: D 200 (version -22) – Weiße Stöcke und Streben aus Stahl, mit Metallknicker, Handöffnung, höhenverstellbar, Unterstock mit Hebel.

D 200 – Weißen Stahlstöcke, Weißen Stahlstreben, mit Nylon Knicker, Handöffnung, feste Höhe, Unterstock mit Hebel.

D200, D230 – Stock 33/37 mm aus Aluminium, Hackenstreben aus galvanisiert Stahl, Handöffnung, feste Höhe.



kg Peso per base: min kg 15 x D 200, min kg 20 per D 230. Con peso maggiore avrete più stabilità e sicurezza. **Vedere basi pag. 154**

kg Poids pour pied: min 15 kg pour D 200, min 20 kg pour D 230. Avec plus de poids il y aura une majeure stabilité et sécurité. **Voir pieds à la page 154**

kg Weight for base: min 15 kg for D 200, min 20 kg for D 230. With higher weight, there are better stability and safety. **See bases on page 154**

kg Gewicht für Ständer: min 15 kg für D 200, min 20 kg für D 230. Mit höher Gewicht, es gibt besser stabilität und Sicherheit. **Ständer Seite 154**

Colori/Couleurs/Colours/Farben Art. 181-181A



Colori/Couleurs/Colours/Farben Art. 182A

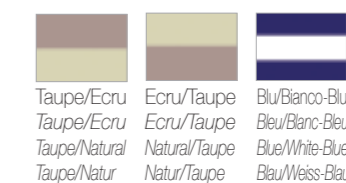

MAFFEI É ANCHE

La collezione comprende anche vele, fodere, basi e cuscini in coordinato che permettono di offrire una gamma completa di qualità Maffei.

MAFFEI, PAS SEULEMENT PARASOLS...

La collection comprend voiles d'ombrage, housses de protection, coussins coordonnés pour compléter l'offre de la gamme Maffei.

MAFFEI NOT ONLY PARASOLS

Maffei's collection includes shade sails, protection covers, bases and matching cushions which comply with our manufacturing quality.

MAFFEI ZUBEHÖR UND ACCESSOIRES

Diese Kollektion umfasst Sonnensegel, vielseitige Abdeckungen, Plattenständer und farblich abgestimmte Gartenmöbelauflagen, die keine Wünsche offen lässt.





Mytex Fodere di protezione impermeabili e traspiranti

CARATTERISTICHE TECNICHE

TESSUTO: Mytex a 3 strati accoppiati, tinto in pasta, impermeabile colonna d'acqua, traspirante, dotato di ottima resistenza alla trazione ed alla lacerazione (prova chiodo), di protezione anti UV, di resistenza colori 7. Ha la capacità di lasciare uscire l'umidità, pur essendo impermeabile, garantendo una protezione ottimale da sporco, agenti atmosferici, ruggine, muffe.

PRODUZIONE: cuciture rinforzate con bordo, chiusura con fibbie regolabili o lacci (dipende dal prodotto).

AVVERTENZA: in caso di acquisto occorre sempre verificare che il prodotto da coprire sia almeno 5 cm più corto e stretto della fodera.

Mytex Housses de protection imperméables et transpirantes.

CARACTÉRISTIQUES TECHNIQUES

TISSU: Mytex, avec 3 couches couplées, teinté en masse, imperméable colonne d'eau, transpirant, avec optimale résistance à la traction et à la laceration (essai clou), de protection anti UV, avec résistance couleurs 7. Il a la capacité, étant imperméable, de laisser sortir l'humidité, en offrant une protection contre la saleté, les intempéries, la rouille, la moisissure.

FINITIONS: coutures renforcées avec bord, fermeture avec boucles réglables ou lacets (selon produit).

ATTENTION: en cas d'achat il faut contrôler que le produit à protéger soit au moins 5 cm en longueur et largeur plus petit que la housse.

Mytex Waterproof and breathable protection covers.

TECHNICAL FEATURES

FABRIC: Mytex 3 coupled layers, solution dyed, water column waterproof, breathable, with very good resistance to textile strength and nail tear strength, anti UV protection, colour fastness 7. This fabric, being waterproof, can let the humidity exit, offering a protection against dirt, bad weather, rust and mould.

FINISHING: reinforced seams with band, closing with adjustable buckles or tie-bands (depending on the item).

ATTENTION: in case of purchase it's necessary to control that the product to cover is at least 5 cm shorter and narrower than the cover.

Mytex Wasserabstoßend imprägnierte und atmungsaktive Schutzhüllen.

TECHNISCHE EIGENSCHAFTEN

STOFF: Mytex 3 Schichten Verbundstoff, Spinnfärbefärbte, Wassersäule, hoch Atmungsaktiv klassifiziert, sehr gut Höckstzugkraft und Weiterreisfestigkeit, UV Schutz, Lichtechtheit 7. Das Gewebe ist beide Wasserabstoßend imprägniert und Atmungsaktiv, so kann Schutz von Schmutz, Witterung, Rost und Schimmel anbieten.

FINISH: verstärker Nähte mit Band, Verstellbarer Verschluss mit Schnalle, oder Band (nach Modell).

ACHTUNG: beim Kauf, bitte prüfen dass die zu schützenden Objekte mindestens 5 cm engere und kurzen müssen sein.



Impermeabile
Imperméable
Waterproof
Undurchlässig

Raggi UV
Les rayons UV
UV rays & light
UV-Strahlen

Umidità
Humidité
Humidity
Feuchtigkeit

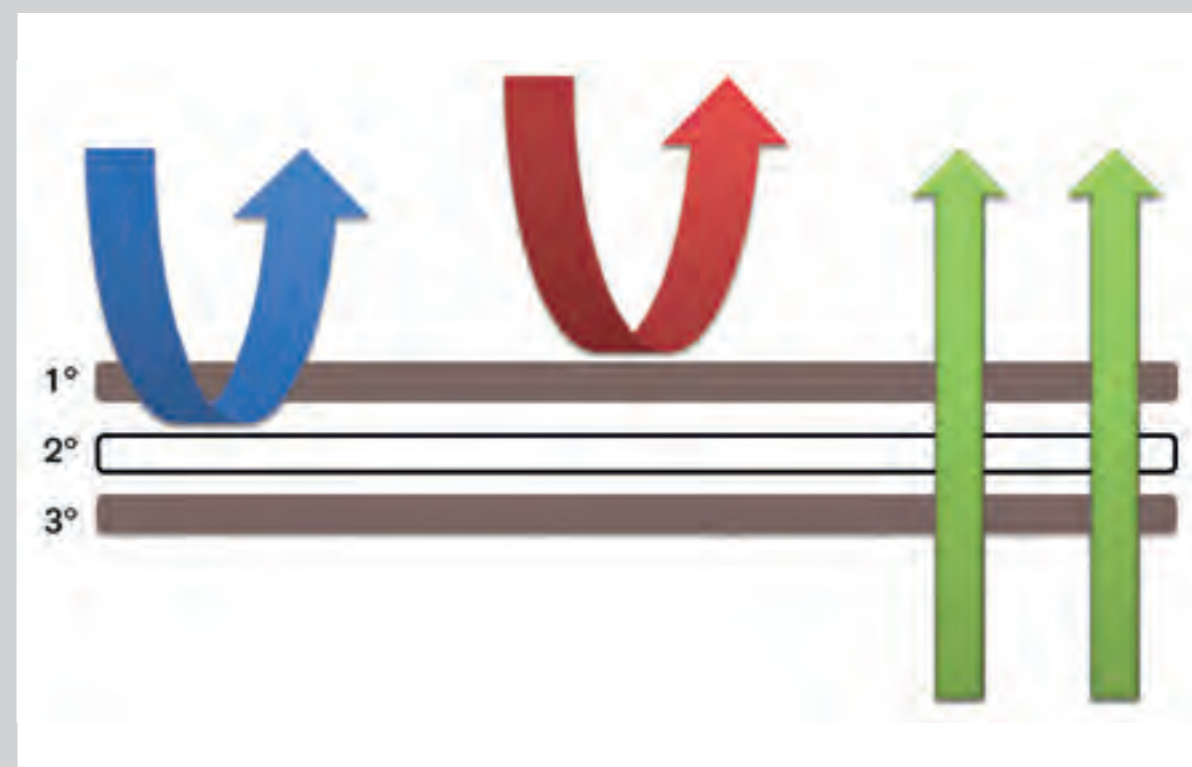

■ Tessuto 1° strato
Tissu 1ère couche
Fabric 1° layer
Stoff 1 Schicht

□ Tessuto 2° strato
Tissu 2ème couche
Fabric 2° layer
Stoff 2 Schicht

■ Tessuto 3° strato
Tissu 3ème couche
Fabric 3° layer
Stoff 3 Schicht

Art. 920 cm 140x30

- Per ombrelloni fino a mt 2
- Pour parasol jusqu'à 2 mt
- For parasols till mt 2
- Für Sonnenschirme von bis 2 mt



Art. 920R cm 160x45

- Per ombrelloni rafia mt 2
Maffei Art. 6 e 7
- Pour parasol rafia jusqu'à 2 mt
Maffei Art. 6 et 7
- For rafia parasols mt 2
Maffei Art. 6 and 7
- Für Bastschirmen von bis 2 mt
Maffei Art. 6 und 7



Art. 922 cm 260x49

- Per ombrelloni a palo centrale fino a mt 3x4
e laterali ripiegabili fino a mt 3x2
- Pour parasols mât central jusqu'à 3x4 mt/déportés
repliables jusqu'à 3x2 mt
- For parasols with central pole till 3x4 mt
and folding side pole till 3x2 mt
- Für Zentralstocksonnenschirme von bis
3x4 mt/einziehbare Ampelschirm von bis 3x2 mt



Con bastone
Avec bâton
With pole
Mit Stock

Art. 921 cm 200x30

- Per ombrelloni fino a mt 3/rettangolare
mt 3x2
- Pour parasol jusqu'à 3 mt/rectangulaire
3x2 mt
- For parasols till 3 mt/rectangular 3x2 mt
- Für Sonnenschirme von bis 3 mt/
rechteckig 3x2 mt



Art. 921

Art. 921-P3

- Per ombrelloni Parrot
- Pour parasol Parrot
- For parasol Parrot
- Für Parrot Wandschirm



Art. 921-P3

Art. 922T cm 275/300x57

- Per ombrelloni laterali retrattili fino a mt 3x4
Maffei Art 226-227-448Q-449R
- Pour parasols déportés retractables jusqu'à 3x4 mt
Maffei Art 226-227-448Q-449R
- For folding side pole till 3x4 mt
Maffei Art 226-227-448Q-449R
- Für einziehbare Ampelschirm von bis 3x4 mt
Maffei Art 226-227-448Q-449R



Con bastone
Avec bâton
With pole
Mit Stock

Art. 922TE cm 320x57

- Per ombrelloni palo centrale telescopici fino a mt 4x4
- Pour parasols mât central télescopiques jusqu'à 4x4 mt
- For telescopic central pole parasols till 4x4 mt
- Für Teleskop Sonnenschirm bis 4x4 mt



Con bastone
Avec bâton
With pole
Mit Stock



Art. 925 cm 275/295x55/35

- Per ombrelloni a palo retrattile fino a mt 4x4 Maffei Art. 188Q-189R-208Q-209R
- Pour parasols déportés jusqu'à 4x4 mt Art. 188Q-189R-208Q-209R
- For side folding umbrellas up to 4x4 mt Maffei Art. 188Q-189R-208Q-209R
- Für Ampelschirme mit ausfahbarem Arm bis 4x4 mt Maffei Art. 188Q-189R-208Q-209R



Con bastone
Avec bâton
With pole
Mit Stock



Art. 923 cm 310x75

- Per ombrelloni laterali a braccio fisso fino a mt 3x4 Maffei Art. 157-158-159
- Pour parasol mât déporté fix jusqu'à 3x4 mt Maffei Art. 157-158-159
- Für Ampelschirme bis zu 3x4 mt Maffei Art. 157-158-159
- For fixed arm side pole till 3x4 mt Maffei Art. 157-158-159



Con bastone
Avec bâton
With pole
Mit Stock



Art. 929 cm 65x65x90/120

- Per sedie a schienale basso impilate
- Pour chaises dossier bas impilables
- For stacked low back chairs
- Für stapelbare Niederlehner Stühle



Art. 933 cm 190x72x37/37

Art. 934 cm 210x72x37/37

- Per lettini
- Pour bain de soleil
- For sun beds
- Für Liegen

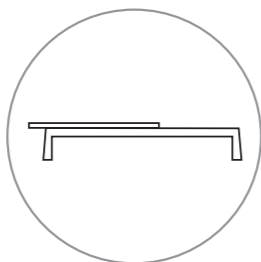

Art. 950 cm 170x60x110/30

- Per tagliaerba
- Pour tondeuse
- For lawn mower
- Für Rasenmäher



Art. 935 cm 190x100x80

Art. 936 cm 160x100x80

Art. 939 cm 230x130x90

- Per tavoli rettangolari/set tavolo + sedie
- Pour table rectangulaire/set table+chaises
- For rectangular table/set table + chairs
- Für rechteckiger Tisch und Tisch & Stuhl Set

Art. 937 cm 100x100x80

- Per tavoli quadrati/set tavolo + sedie
- Pour table carré/set table carré + chaises
- For square table/set table + chairs
- Für eckiger Tisch und Eckiger Tisch & Stuhl Set

Art. 938 cm 230x130x90

- Per tavoli ovali/set tavolo + sedie
- Pour table ovale/set table ovale+chaises
- For oval table/set table + chairs
- Für ovaler Tisch und ovaler Tisch & Stuhl Set

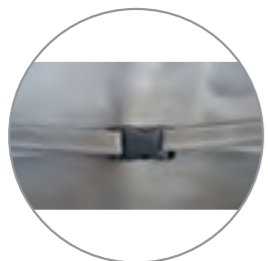

Art. 955 cm 210x90x120

- Per trattorino tagliaerba e mobiletti
- Pour tracteur tondeuse et petits meubles
- Für Aufsitzmähe et little furniture
- For little tractor und kleine Möbel

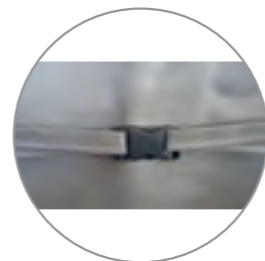

Art. 961 cm 152x95/40x160

- Per tavolo ping pong
- Pour tennis de table
- For tennis table
- Für Tischtennisplatten

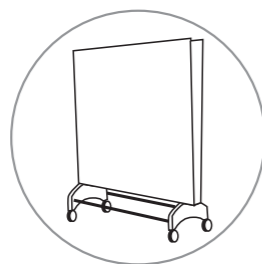
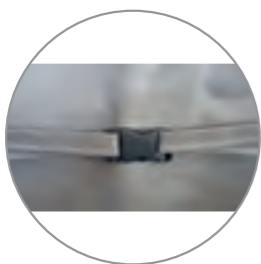

Art. 986 cm 220x150x160

- Per dondolo
- Pour balancelle
- For swing chair
- Für Hollywoodschaukel

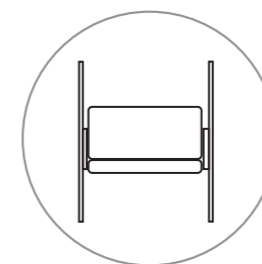
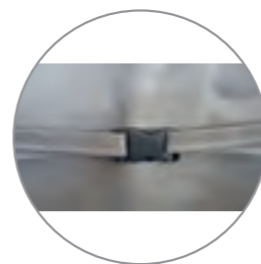

Art. 965 cm 80x70x75

Art. 966 cm 140x70x105

Art. 967 cm 180x72x105

- Per BBQ - piccolo / medio / grande
- Pour BBQ - petit / medium / grand
- For BBQ - little / medium / large
- Für Grill - klein / mittel / groß

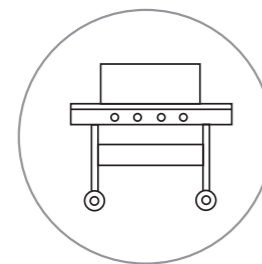

- SERVIZIO FODERE SU MISURA
- SERVICE HOUSSE SUR MESURE
- SERVICE COVERS ON DEMAND
- SERVICE SCHUTZHÜLLEN NACH MASS

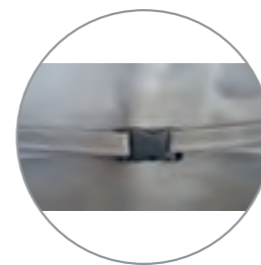

BASI/PIEDS



BASES/STÄNDER

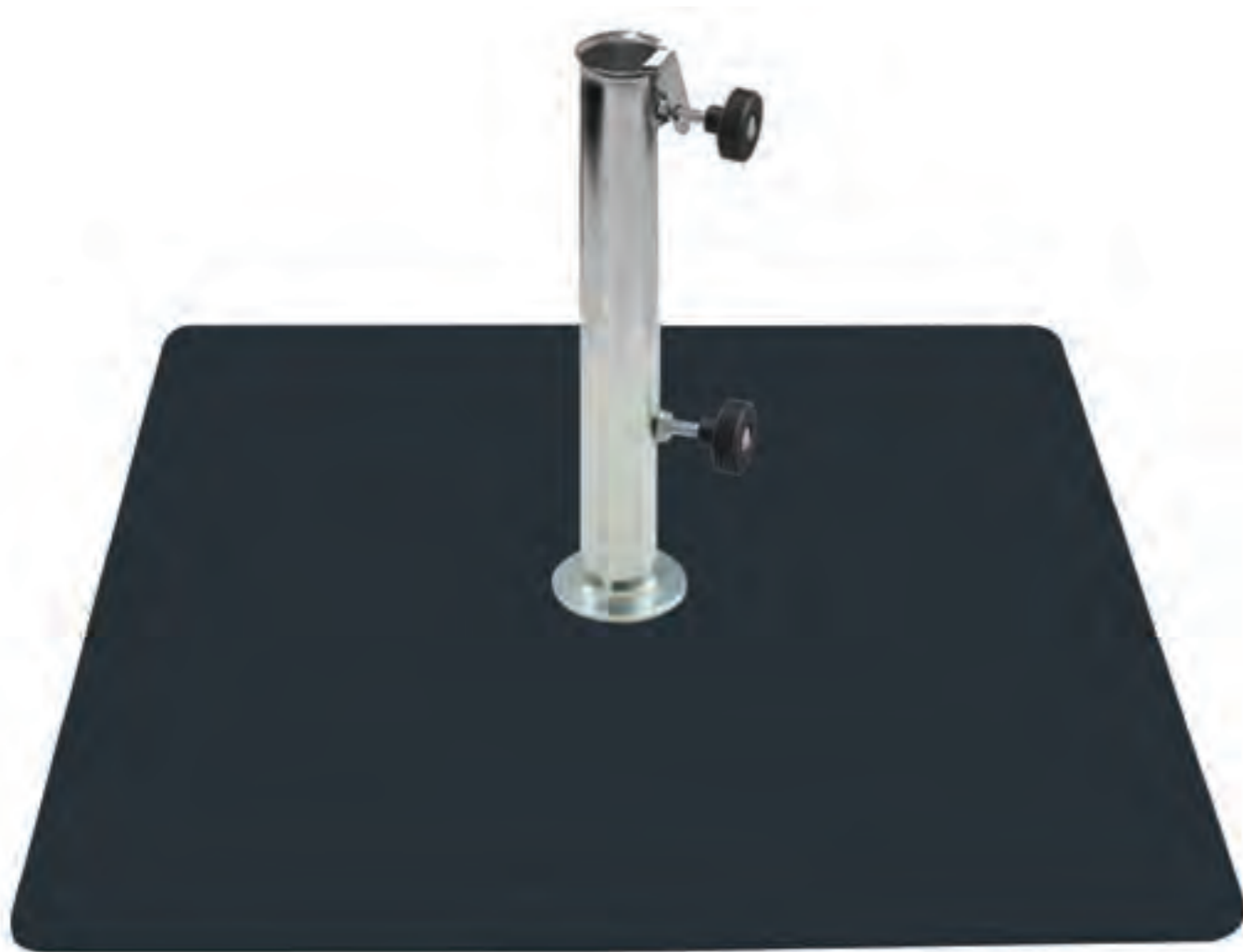

Art 358 GRAFITE/GRAPHITE/GRAPHIT + TUBO/TUBE/ROHR 45MM



Art 304 GRIGIO/GRIS/GREY/GRAU + TUBO/TUBE/ROHR 55MM



Art. 356-GRA-38
Art. 356-GRA-45
Art. 356-GRA-55



cm 62x62x1 – kg 30

- Base metallica calpestabile, colore grafite, predisposizione ruote/tasselli/piedini
- Pied métallique pietinable, couleur graphite, avec prédisposition pour roulettes/tasseaux/pieds
- Metal walkable base, graphite colour, with holes to assemble wheels/anchors/feet
- Metallständer, begehbar, farbe Graphit, mit Vorkehrung für Räder/Dübel/ Füßen

tubo/tube/tube/Rohr 38 mm
tubo/tube/tube/Rohr 45 mm
tubo/tube/tube/Rohr 55 mm

Art. 358-GRA-38
Art. 358-GRA-45

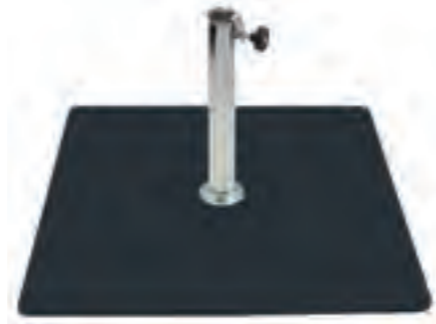

cm 62x62x0,6 – kg 20

- Base metallica calpestabile, colore grafite, predisposizione ruote/tasselli/piedini
- Pied métallique pietinable, couleur graphite, avec prédisposition pour roulettes/tasseaux/pieds
- Metal walkable base, graphite colour, with holes to assemble wheels/anchors/feet
- Metallständer, begehbar, farbe Graphit, mit Vorkehrung für Räder/Dübel/ Füßen

tubo/tube/tube/Rohr 38 mm
tubo/tube/tube/Rohr 45 mm



Art. 356-BIA-38
Art. 356-BIA-45
Art. 356-BIA-55



cm 62x62x1 – kg 30

- Base in metallo calpestabile, colore bianco, predisposizione ruote/tasselli/piedini
- Pied métallique pietinable, couleur blanc, avec prédisposition pour roulettes/tasseaux/pieds
- Metal walkable base, white colour, with holes to assemble wheels/anchors/feet
- Metallständer, begehbar, farbe Weiß, mit Vorkehrung für Räder/Dübel/ Füßen

tubo/tube/tube/Rohr 38 mm
tubo/tube/tube/Rohr 45 mm
tubo/tube/tube/Rohr 55 mm

Art. 358-BIA-38
Art. 358-BIA-45



cm 62x62x0,6 – kg 20

- Base metallica calpestabile, colore bianco, predisposizione ruote/tasselli/piedini
- Pied métallique pietinable, couleur blanc, avec prédisposition pour roulettes/tasseaux/pieds
- Metal walkable base, white colour, with holes to assemble wheels/anchors/feet
- Metallständer, begehbar, farbe Weiß, mit Vorkehrung für Räder/Dübel/ Füßen

tubo/tube/tube/Rohr 38 mm
tubo/tube/tube/Rohr 45 mm

Art. 356X-GRA-65



cm 62x62x2 – kg 60

- Base metallica calpestabile, colore grafite, predisposizione ruote/tasselli/piedini, composta da due piastre sovrapposte
 - Pied métallique pietinable, couleur graphite, avec prédisposition pour roulettes/tasseaux/pieds. Le pied est composé par deux dalles superposées.
 - Metal walkable base, graphite colour, with holes to assemble wheels/anchors/feet. The base is made by two stacked plates
 - Metallständer, begehbar, farbe Graphit, mit Vorkehrung für Räder/Dübel/ Füßen. Der Ständer besteht auf 2 überlappenden Platten
- tubo/tube/tube/Rohr 65 mm**

Opzione/Option/Option/Option



- Ruote doppie con freno
- Double wheel with brake
- Double roulettes avec frein
- Doppelrad mit Bremse



- Piedino
- Feet
- Pieds
- Füßen

Art. 356X-BIA-65



cm 62x62x2 – kg 60

- Base metallica calpestabile, colore bianco, predisposizione ruote/tasselli/piedini, composta da due piastre sovrapposte
 - Pied métallique pietinable, couleur blanc, avec prédisposition pour roulettes/tasseaux/pieds. Le pied est composé par deux dalles superposées.
 - Metal walkable base, white colour, with holes to assemble wheels/anchors/feet. The base is made by two stacked plates.
 - Metallständer, begehbar, farbe Weiß, mit Vorkehrung für Räder/Dübel/ Füßen. Der Ständer besteht auf 2 überlappenden Platten
- tubo/tube/tube/Rohr 65 mm**

Opzione/Option/Option/Option



- Ruote doppie con freno
- Double wheel with brake
- Double roulettes avec frein
- Doppelrad mit Bremse



- Piedino
- Feet
- Pieds
- Füßen



Art. 304-38 Art. 304-45



cm 50x50x3,6 – kg 20

- Base in cemento disegno legno, grigio
- Pied en béton finition bois couleur gris
- Concrete base with wood design, grey
- Betonplatteständer, design: Holz, farbe Grau

tubo/tube/tube/Rohr 38 mm
tubo/tube/tube/Rohr 45 mm

Art. 304B-38 Art. 304B-45



cm 50x50x3,6 – kg 20

- Base in cemento disegno legno, grigio
- Pied en béton finition bois couleur gris
- Concrete base with wood design, grey
- Betonplatteständer, design: Holz, farbe Grau

tubo/tube/tube/Rohr 38 mm
tubo/tube/tube/Rohr 45 mm



Art. 304-MA-38 Art. 304-MA-45



cm 50x50x3,6 – kg 20

- Base in cemento disegno legno, marrone
- Pied en béton finition bois couleur marron
- Concrete base with wood design, brown
- Betonplatteständer, design: Holz, farbe Braun

tubo/tube/tube/Rohr 38 mm
tubo/tube/tube/Rohr 45 mm

Art. 304B-MA-38 Art. 304B-MA-45



cm 50x50x3,6 – kg 20

- Base in cemento disegno legno, marrone
- Pied en béton finition bois couleur marron
- Concrete base with wood design, brown
- Betonplatteständer, design: Holz, farbe Braun

tubo/tube/tube/Rohr 38 mm
tubo/tube/tube/Rohr 45 mm

Art. 304X-55 Art. 304X-65



cm 50x50x7,2 – kg 40

- Base in cemento disegno legno, grigio.
La base è composta da nr. 2 piastrelloni sovrapposti.
- Pied en béton finition bois couleur gris. Le pied est composé par 2 dalles superposés.
- Concrete base with wood design, grey. The base is composed by 2 stacked tiles.
- Betonplatteständer, design: Holz, farbe Grau. Der Ständer bestehen auf 2 überlappenden Platten.

tubo/tube/tube/Rohr 55 mm
tubo/tube/tube/Rohr 65 mm



- Vite di sicurezza
- Vis de sécurité
- Safety screw
- Sicherheitsschraube

Art. 304X-MA-55 Art. 304X-MA-65



cm 50x50x7,2 – kg 40

- Base in cemento disegno legno, marrone.
La base è composta da nr. 2 piastrelloni sovrapposti.
- Pied en béton finition bois couleur marron. Le pied est composé par 2 dalles superposés.
- Concrete base with wood design, brown. The base is composed by 2 stacked tiles.
- Betonplatteständer, design: Holz, farbe Braun. Der Ständer bestehen auf 2 überlappenden Platten.

tubo/tube/tube/Rohr 55 mm
tubo/tube/tube/Rohr 65 mm



- Vite di sicurezza
- Vis de sécurité
- Safety screw
- Sicherheitsschraube



Art. 304-BIA-38 Art. 304-BIA-45



cm 50x50x3,6 – kg 20

- Base in cemento disegno legno, bianco.
- Pied en béton finition bois couleur blanc.
- Concrete base with wood design, white.
- Betonplatteständer, design: Holz, farbe Weiß.

tubo/tube/tube/Rohr 38 mm
tubo/tube/tube/Rohr 45 mm

Art. 304B-BIA-38 Art. 304B-BIA-45



cm 50x50x3,6 – kg 20

- Base in cemento disegno legno, bianco.
- Pied en béton finition bois couleur blanc.
- Concrete base with wood design, white.
- Betonplatteständer, design: Holz, farbe Weiß.

tubo/tube/tube/Rohr 38 mm
tubo/tube/tube/Rohr 45 mm



Art. 320-BIA-27



D cm 44 – kg 27

- Base in cemento ricoperta plastica con tubo, adatta a bastoni ombrelloni mm 33/40.
- Pied en béton couvert avec plastique avec tube et adaptateurs.
- Pour mât parasols mm 33/40. Concrete base covered with resin, with tube, fits umbrellas with pole 33/40 mm.
- Kunststoff abgedeckt Betonständer mit Rohr und Adapter. Für Stöcke mm 33/40.

Art. 320-BIA-54



D cm 44 – kg 54

- Base in cemento ricoperta plastica con tubo, adatta a bastoni ombrelloni mm 33/40. Composta da due dischi sovrapposti.
- Pied en béton couvert avec plastique avec tube et adaptateurs. Pour mât parasols mm 33/40.
- Concrete base covered with resin, with tube, fits umbrellas with pole 33/40 mm. The base is made by two stacked disk.
- Kunststoff abgedeckt Betonständer mit Rohr und Adapter tiers. Für Stöcke mm 33/40.

Art. 304X-BIA-55 Art. 304X-BIA-65



cm 50x50x7,2 – kg 40

- Base in cemento disegno legno, bianco. La base è composta da nr. 2 piastrelloni sovrapposti.
- Pied en béton finition bois couleur blanc. Le pied est composé par 2 dalles superposées.
- Concrete base with wood design, white. The base is composed by 2 stacked tiles.
- Betonplatteständer, design: Holz, farbe Weiß. Der Ständer bestehen auf 2 überlappenden Platten.

tubo/tube/tube/Rohr 55 mm
tubo/tube/tube/Rohr 65 mm



- Vite di sicurezza
- Vis de sécurité
- Safety screw
- Sicherheitsschraube

Art. 322-BIA



D cm 44 – kg 27

- Set base e tavolino. Adatto a bastoni ombrelloni mm 40.
- Set pied et tablette. Adapté a mât parasol mm 40.
- Set base and table. Fits umbrellas with pole 40 mm.
- Ständer und Tischchen Kombi Geeinet für Stöcke mm 40.



- Particolare base Art. 320-322
- Base detail Art. 320-322
- Détail pied Art. 320-322
- Detail Ständer Art. 320-322

BASI/PIEDS/BASES/STÄNDER



Art. 301-38 Art. 301-55
Art. 301-45 Art. 301-65



D cm 54 – kg 35

- Base graniglia
- Pied en grès
- Grit base
- Waschbetonständer

tubo/tube/tube/Rohr 38 mm
tubo/tube/tube/Rohr 45 mm
tubo/tube/tube/Rohr 55 mm
tubo/tube/tube/Rohr 65 mm

Art. 302-38
Art. 302-45



D cm 44 – kg 25

- Base graniglia
- Pied en grès
- Grit base
- Waschbetonständer

tubo/tube/tube/Rohr 38 mm
tubo/tube/tube/Rohr 45 mm

BASI/PIEDS/BASES/STÄNDER



Art. 300



cm 38x38x11 – 15 L

- Base plastica bianca con tubo, per pali mm 25-33.
- Pied plastique blanc avec tube pour mâts 25-33 mm..
- White plastic base with tube, for poles 25-33 mm.
- Plastikständer, weiss mit Rohr für Stock 25-33 mm

Art. 360



D cm 58 – kg 45

- Base in granito con ruote.
- Base en granit avec roues
- Granite base with wheels.
- Granitsockel mit Rädern

tubo/tube/tube/Rohr 45 mm

Art. 310-55
Art. 310-65



D cm 59 – kg 55

- Base in graniglia con maniglie.
- Pied en grès avec poignées
- Grit base with handles.
- Betonständer mit Griffe

tubo/tube/tube/Rohr 55 mm
tubo/tube/tube/Rohr 65 mm

Art. 311-65



D cm 65 – kg 75

- Base in graniglia con maniglie.
- Pied en grès avec poignées
- Grit base with handles.
- Betonständer mit Griffe

tubo/tube/tube/Rohr 65 mm

Art. 361-38
Art. 361-45
Art. 361-55

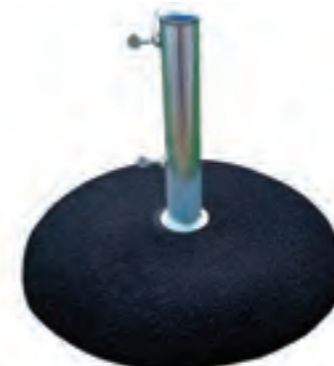

D cm 54 – kg 35

- Base in cemento
- Pied en béton
- Concrete base
- Betonständer

tubo/tube/tube/Rohr 38 mm
tubo/tube/tube/Rohr 45 mm
tubo/tube/tube/Rohr 55 mm

Art. 362-38
Art. 362-45

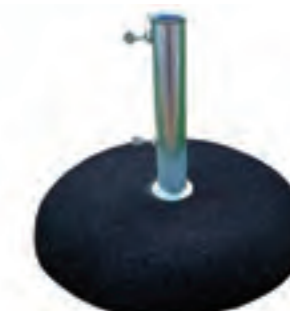

D cm 44 – kg 25

- Base in cemento
- Pied en béton
- Concrete base
- Betonständer

tubo/tube/tube/Rohr 38 mm
tubo/tube/tube/Rohr 45 mm

Tubo/tube mm 38 - per pali ombrelloni fino a 33 mm/pour mâ parasol jusqu'à 33 mm
Tube/Rohr mm 38 - for parasol poles up to 33 mm/für Stock bis 33 mm
Tubo/tube mm 45 - per pali ombrelloni fino a 30-38 mm/pour mâ parasol jusqu'à 30-38 mm
Tube/Rohr mm 45 - for parasol poles 30-38 mm/für Stock 30-38 mm

Tubo/tube mm 55 - per pali ombrelloni fino a 40-48 mm/pour mâ parasol jusqu'à 40-48 mm
Tube/Rohr mm 55 - for parasol poles 40-48 mm/für Stock 40-48 mm
Tubo/tube mm 65 - per pali ombrelloni fino a 50-58 mm /pour mâ parasol jusqu'à 50-58 mm
Tube/Rohr mm 65 - for parasol poles 50-58 mm/für Stock 50-58 mm

BASI/PIEDS/BASES/STÄNDER



Art. 303
cm 50x50x3,7
kg 20

- Piastrellone in graniglia
- Dalle en grès
- Grit tile
- Waschbetonplatte



Art. 305
cm 50x50x3,6
kg 20

- Piastrellone in cemento disegno legno, grigio
- Dalle en béton finition bois couleur gris
- Concrete tile with wood design, grey
- Betonplatte, design: Holz, farbe grau



Art. 305-MA
cm 50x50x3,6
kg 20

- Piastrellone in cemento disegno legno, marrone
- Dalle en béton finition bois couleur marron
- Concrete tile with wood design, brown
- Betonplatte, design: Holz, farbe braun

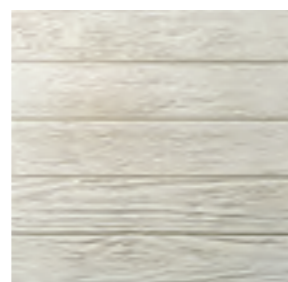

Art. 305-BIA
cm 50x50x3,6
kg 20

- Piastrellone in cemento disegno legno, bianco
- Dalle en béton finition bois couleur blanc
- Concrete tile with wood design, white
- Betonplatte, design: Holz, farbe weiß

Art. 352

- Base da interrare in alluminio per ombrelloni a palo centrale composta da trivella calpestabile e supporto. Si adatta a pali ombrelloni mm 20-50.
- Pied à enterrer en aluminium pour parasols mât central, composé par une tarière et support. Pour mât parasols 20-50 mm
- Ground base for side pole parasols composed by a walkable drill and a support. Fits parasols poles 20-50 mm.
- Alu Sockel für Sonnenschirm besteht aus Ankerfuss und Unterstützung für Sonnenschirme mit Stock 20-50 mm



Adattatore
Adaptateur
Holder
Adapter



Supporto + Trivella
Adaptateur + tarière
Holder + drill
Adapter+Anker



Calpestabile
Fil sol
Walkable
Begehbar

BASI/PIEDS/BASES/STÄNDER



Art. 353

- Base da interrare in alluminio per ombrelloni laterali composta da trivella calpestabile e supporto.
- Pied à enterrer pour parasols déportés composé par base d'ancrage et support
- Ground anchor for side umbrellas made by a walkable drill and a support.
- Alu Sockel für Ampelschirm besteht aus Ankerfuss und Unterstützung



Supporto + Trivella
Adaptateur+ancrage
Holder + drill
Adapter+Anker

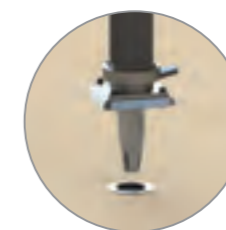

MANTA



Art. 1503 cm 300x400x400

Art. 1504 cm 400x400x400

Art. 1505 cm 500x500x500



Art. 1505 ECRU/NATURAL/NATUR



- Angoli con lacci rinforzati
- Angles avec lacets renforcés
- Corners with reinforced band
- Ecken mit verstärktes Band



- Aggancio per muro in acciaio inox
- Crochet pour mur en acier inox
- Stainless steel hooks for wall
- Haken für Wand



- Cuciture rinforzate
- Coutures renforcées
- Reinforced seams
- Verstärkte Nähte

🇮🇹 Manta Vela per giardino

CARATTERISTICHE TECNICHE

TESSUTO: PolyMa poliestere gr 210 mc, idrorepellente, antimuffa, protezione UV 50+, resistenza colori 6+.

ACCESSORI: agganci per muro in acciaio inox e corde sono inclusi. Pali telescopici in alluminio disponibili su richiesta (quantità minima richiesta).

🇫🇷 Manta Voile d'ombrage

CARACTÉRISTIQUES TECHNIQUES

TISSU: PolyMa Polyester, gr 210 mc, hydrofuge, anti-moisissure, protection UV 50+, résistance couleurs 6+.

STRUCTURE: crochets pour mur en acier inox et cordes sont inclus. Mâts télescopiques alu disponibles sur demande (quantité minimale demandée).

🇬🇧 Manta Shade sails

TECHNICAL FEATURES

FABRIC: PolyMa Polyester gr 210 sm, water-repellent, mouldproof, UV protection 50+, colour fastness 6+.

FRAME: stainless steel wall hooks and ropes are included. Alu telescopic poles available on demand (minimum quantity required)

🇩🇪 Manta Sonnensegeln für Garten

TECHNISCHE EIGENSCHAFTEN

STOFF: PolyMa Polyester gr 210 qm, Wasserabstoßend imprägniert, Verrottungsfest, UV Schutz 50+, Lichtechtheit 6+.

GESTELL: Platte zur Wandverankerung aus Edelstahl und Seile sind erhalten. Alu teleskop Stocke auf Anfrage (Mindestmenge erforderlich).



Colori/Couleurs/Colours/Farben

		Altri colori Autres couleurs Other colours Andere Farben
Bianco Blanc White Weiss	Ecru Ecrú Natural Natur	su richiesta sur demande on demand auf Anfrage

ALLEGRO

CUSCINI/COUSSINS
CUSHIONS/POLSTER



Art. 700 cm 40x40x5

Art. 701 cm 45x45x5

Art. 721 cm 90x45x5

Art. 731 cm 190x57x5



Art. 701 ROSSO/ROUGE/RED/ROT

[168]



Art. 731 BLU/BLEU/BLEUE/BLAU



Art. 721 ECRU/NATURAL/NATUR

[169]

CUSCINI/COUSSINS/CUSHIONS/POLSTER

I cuscini da esterno Maffei sono prodotti con gli stessi tessuti molto resistenti degli ombrelloni, al fine di creare un coordinato. Sono sfoderabili e la schiuma interna è a lastra unica, per semplificarne la gestione in caso di uso intenso.

Les coussins pour extérieur Maffei ont le même tissu résistant que les parasols, à fin de créer un set avec les parasols. Ils sont déhoussables et la mousse est à couche unique, pour simplifier la gestion en cas d'usage intensif.

The outdoor cushions Maffei have the same resistant fabric as the parasols, to match them. The cover is easily removable and the filling is a polyurethane block, to manage them better in case of heavy use.

Die Polster von Maffei haben dieselbe robuste Gewebe als die Sonnenschirme, um die Sonnenschirm dazu passen. Sie sind Abziehbar, die Schaum ist ein Schicht, um einfach zu handhaben bei intensiver Nutzung.



■ Laccetti
■ Lacets
■ Tie-bands
■ Schlingen



■ Sfoderabile con cerniera
■ Dehoussable avec fermeture éclair
■ Removable cover with zip
■ Abziehbar mit zip



■ Cuciture
■ Coutures
■ Seams
■ Nähte

Allegro Cuscini da esterno

CARATTERISTICHE TECNICHE

TESSUTO: Dralon Acrilico 100% gr 190 mq, finitura Sun, protezione UV 20/50+ (dipende dal colore), resistenza colori 5-6 (dipende dal colore). Sfoderabile con zip.

IMBOTTITURA: schiuma poliuretano in lastra unica, densità 21, spessore cuscino cm 5. Poliuretano senza CFC.

Allegro Coussins pour extérieur

CARACTÉRISTIQUES TECHNIQUES

TISSU: Dralon Acrylique 100%, gr 190 mc, finition sun, protection UV 20/50+(selon couleur), résistance couleurs 5-6 (selon couleur). Dehoussable avec fermeture éclair.

REPLISSAGE: mousse polyurethane en couche unique, densité 21, épaisseur coussin 5 cm.

Allegro Cushions for outdoor

TECHNICAL FEATURES

FABRIC: Dralon Acrylic 100% gr 190 sm, sun finish, UV protection 20/50+(depending on colour), colour fastness 5-6 (depending on colour). Removable cover with zip.

FILLING: Polyurethane block, density 21, cushion thickness 5 cm.

Allegro Polster

TECHNISCHE EIGENSCHAFTEN

STOFF: Dralon Acryl 100%, gr 190 qm Sun beschichtet, UV Schutz 20/50+ (es kommt aus die Farbe an), Lichtechtheit 5/6 (es kommt aus die Farbe an). Der Sonnenschirm hat eine Schlingenverschluss. Abziehbar mit zip.

FÜLLUNG: Schicht aus Polyurethane, Dichte 21, Polster Dicke 5 cm.

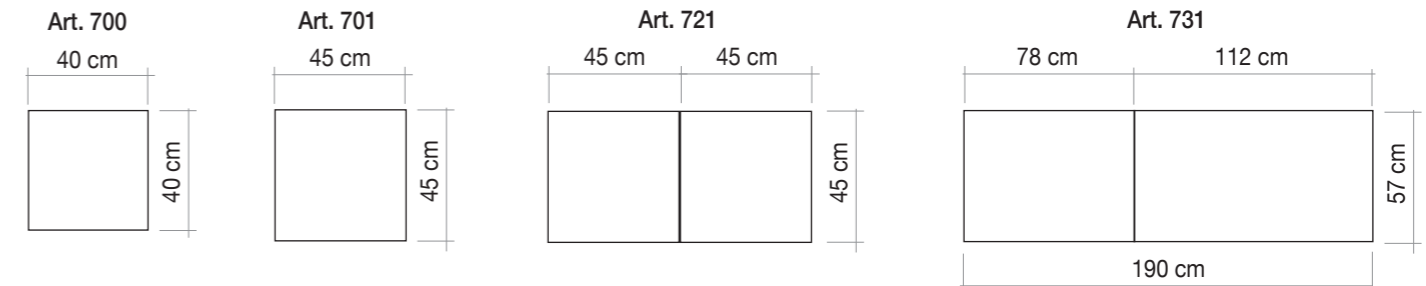

Colori/Couleurs/Colours/Farben Art. 700/701

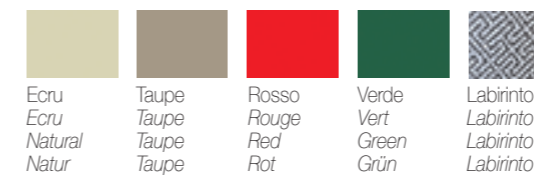

Colori/Couleurs/Colours/Farben Art. 721

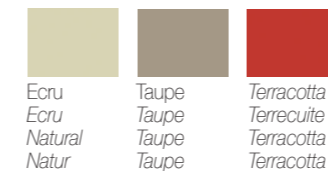

Colori/Couleurs/Colours/Farben Art. 731

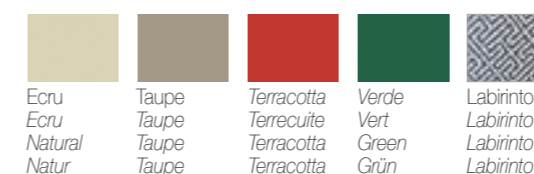

Colori speciali/Couleurs spéciales/Special colours/Sonderfarben

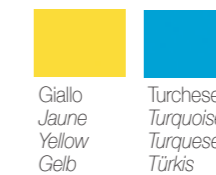

Colori speciali/Couleurs spéciales/Special colours/Sonderfarben



Colori speciali/Couleurs spéciales/Special colours/Sonderfarben

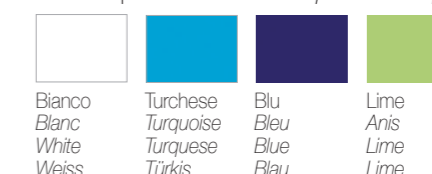



RINGRAZIAMENTI / CREDITS

Agriturismo La Capuccina - Cureggio (NO) - www.lacapuccina.it
Motonautica San Giulio - Pella (NO) - www.msg-bassotto.it
Comune di Pella (NO)
Castello Dal Pozzo - Oleggio Castello (NO) - www.castellodalpozzo.com
Villa Claudia - Belgirate (VB) - www.villaclaudiadalpozzo.com
Palara Web Design - Borgomanero (NO)

MAFFEI S.R.L. a socio unico
Via Boggia, 17/19
28013 Gattico-Veruno (NO) - Italy
Tel. +39.0322.81819
E-mail: maffei@maffei srl.com
www.maffei srl.com
www.ombrelloniprofessionali.it



www.maffei srl.com



www.ombrelloniprofessionali.it